

# Invacare® LiNX

en Controls System  
Service Manual



DEALER: Keep this manual.  
The procedures in this manual MUST be performed by a qualified technician.



**Yes, you can.®**

© 2018 Invacare Corporation

All rights reserved. Reproduction, duplication or modification in whole or in part is prohibited without prior written permission from Invacare. Trademarks are identified by <sup>™</sup> and <sup>®</sup>. All trademarks are owned by or licensed to Invacare Corporation or its subsidiaries unless otherwise noted.

Invacare reserves the right to alter product specifications without further notice.

# Contents

<b>1 General</b>	<b>5</b>
1.1 About this manual	5
1.2 Symbols in this manual	5
1.3 General information	5
1.4 Images in this manual	5
<b>2 Safety</b>	<b>6</b>
2.1 Safety information	6
2.2 Safety notes on the electrical system	6
<b>3 Assembly</b>	<b>7</b>
3.1 Tightening torques	7
3.2 Imperial to metric conversion chart	7
3.3 Overview Components	8
3.4 Power module mounting	11
3.5 Mounting positions on wheelchairs	12
3.6 Port pin-outs	13
3.7 Actuator Port Configurations (Factory Setup)	13
3.7.1 Port configurations for systems with DLX-REM2xx (EU-Version with Modulite seat)	14
3.7.2 Port configuration for non-expandable systems (US version)	15
3.7.3 Port configuration for systems with DLX-REM400 and DLX-REM500 (with Ultra Low Maxx seat)	16
3.7.4 Port Configurations for Functionkeys	17
3.8 Wiring Diagrams	17
3.9 Mounting the primary remotes	29
3.9.1 Mounting DLX-REM1XX and DLX-REM2XX for Modulite	29
3.9.2 Mounting DLX-REM2XX for Ultra Low Maxx	30
3.9.3 Mounting the DLX-REM400	32
3.9.4 Mounting Toggle Switches on the DLX-REM400	33
3.9.5 Mounting the DLX-REM500	34
3.10 Mounting the secondary remotes	35
3.10.1 Mounting Intuitive Dual Control (IDC)	35
3.10.2 Mounting the DLX-ACU200	35
3.10.3 Mounting the DLX-CR400	36
3.10.4 Mounting the DLX-REM050	37
3.11 Mounting the ASL components	37
3.11.1 Mounting Interface Boxes	37
3.11.2 Mounting the Compact Single Switch Joystick	40
3.11.3 Mounting the Micro Extremity Control Joystick	41
3.11.4 Mounting the Pediatric Compact Joystick	43
3.11.5 Mounting the eclipse tray with proximity sensors	45
3.12 Mounting the 10 way switch	45
3.12.1 Mounting the 10 way switch for Modulite	45
3.12.2 Mounting the 10 way switch for Ultra Low Maxx	46
3.12.3 Changing Labeling	47
<b>4 Replacing Wheelchair Components</b>	<b>48</b>
4.1 General information on setup	48
4.2 Battery Synchronisation on New Batteries	48
4.3 Replacing Power Module as Spare Part	48
4.4 Setup Procedure After Power Module Replacement	48
<b>5 Overview LiNX Access tools</b>	<b>50</b>
5.1 The LiNX Access Key	50
5.1.1 Rename LiNX Access Key (only possible with LiNX Access PC tool)	50
5.2 Overview Functions	51
5.2.1 Overview User Preferences	52
<b>6 Suggested programming procedure</b>	<b>56</b>
6.1 Step 1 – Power-up test	56
6.2 Step 2 – Check motor orientation	56
6.3 Step 3 – Set load compensation	56
6.3.1 Calibrating Adaptive Load Compensation (iOS tool)	57
6.3.2 Calibrating Adaptive Load Compensation (PC tool)	58
6.4 Step 4 – Adjust Speed Settings	58
6.5 Step 5 – Adjust acceleration settings	59

<b>7 Using the LiNX Access iOS tool</b>	<b>61</b>
7.1 Navigation bar	61
7.1.1 Application menu	61
7.1.2 Changing Program Name	61
7.2 Home screen	62
7.3 Connection context actions	62
7.3.1 Connect to device screen	62
7.3.2 Reading a program from the wheelchair	63
7.3.3 Restoring Default Wheelchair Configurations	63
7.3.4 Converting Configuration Files	63
7.3.5 Modifying a Program	63
7.3.6 Writing a program to the wheelchair	64
7.3.7 Saving programs	64
7.3.8 Upgrading firmware	65
7.3.9 Storing the LAK certificate	66
7.4 File context actions	66
7.4.1 Load from file screen	66
7.4.2 Writing Bundle Files	66
7.4.3 Opening files	67
7.4.4 Deleting files	67
7.4.5 E-mailing files	68
<b>8 Modifying wheelchair configuration with iOS tool</b>	<b>69</b>
8.1 Profile And Function Actions	69
8.2 Modifying function and profile names	72
8.3 Modifying drive parameters graphically	72
8.4 Modifying drive parameters numerically	73
8.5 Modifying Lighting Parameters	73
8.6 Modifying Gyro Support in Drive Functions	74
8.7 Programming Toggle Switches	74
8.8 Modifying Seating Parameters	74
8.9 Modifying Attendant Parameters	76
8.10 Joystick Switch Threshold	77
8.11 Adjust quadrant operation	77
8.11.1 Adjust drive directions	78
8.12 Enable indirect navigation	79
8.13 Installing / Setting up alternative inputs	79
8.14 Installing / Setting up Alternative Outputs	80
8.15 Sip and Puff installation	82
8.15.1 Sip and Puff calibration	82
<b>9 Using the LiNX Access PC tool</b>	<b>85</b>
9.1 Installing the software	85
9.1.1 Using Bluetooth on a computer	86
9.2 Layout overview	86
9.3 Concepts	87
9.4 Checking and getting the latest version	87
9.5 Connection context actions	88
9.5.1 Connecting/Disconnecting the LiNX Access PC tool	88
9.5.2 Write a program to a wheelchair	88
9.5.3 Read a program from a wheelchair	88
9.5.4 Save a program as a file	89
9.5.5 Storing the LAK certificate	89
9.5.6 Upgrading Firmware	89
9.5.7 Restoring Default Wheelchair Configurations	89
9.5.8 Loading Default Configurations	90
9.5.9 Converting Configuration Files	91
9.6 File context actions	91
9.6.1 Open/Close a file	91
9.6.2 Remove a file from list	92
9.6.3 Writing bundle files to a chair	92
<b>10 Modifying wheelchair configuration with PC tool</b>	<b>93</b>
10.1 Profile and Function Actions	93
10.2 Modifying function and profile names	94
10.3 Modifying drive parameters	94
10.3.1 Modifying Lighting Parameters	94
10.3.2 Modifying Gyro Support in Drive Functions	95
10.4 Programming Toggle Switches	95
10.5 Modifying Seating Parameters	95
10.6 Modifying Attendant Parameters	98
10.7 Joystick Switch Threshold	98
10.8 Setting up a system for latched driving	99
10.9 Adjust quadrant operation	100
10.9.1 Adjust drive directions	101

10.10	Enable Indirect Navigation . . . . .	101
10.11	Programming external switches . . . . .	102
10.12	Programming multipurpose buttons . . . . .	104
10.13	Installing / Setting up alternative inputs . . . . .	106
10.14	Installing / Setting up Alternative Outputs . . . . .	106
10.15	Sip and Puff installation . . . . .	107
10.15.1	Sip and Puff calibration . . . . .	108
<b>11</b>	<b>Diagnostics . . . . .</b>	<b>110</b>
11.1	Viewing System Summary . . . . .	110
11.2	Viewing Active Errors . . . . .	110
11.3	Viewing Chair Statistics . . . . .	110
11.4	Viewing Live Diagnostics . . . . .	112
11.5	Clearing the event log . . . . .	112
<b>12</b>	<b>Structure of Program Names . . . . .</b>	<b>113</b>
12.1	Where-Used Matrices . . . . .	113
12.2	Naming Format . . . . .	114

# 1 General

## 1.1 About this manual

This service manual contains information about assembly, adjustment and advanced maintenance of the product. In order to ensure safety when handling the product, read the manual carefully and follow the safety instructions.

For pre-sale and user information, please see the user manual. Find the user manual on Invacare's website or contact your Invacare representative (see addresses at the end of this manual).

## 1.2 Symbols in this manual

In this manual, hazard statements are indicated by symbols. The symbols are accompanied by a signal word that indicates the severity of the risk.



### WARNING

Indicates a hazardous situation that could result in serious injury or death if it is not avoided.



### CAUTION

Indicates a hazardous situation that could result in minor or slight injury if it is not avoided.



### IMPORTANT

Indicates a hazardous situation that could result in damage to property if it is not avoided.



Gives useful tips, recommendations and information for efficient, trouble-free use.



This symbol identifies a list of various tools, components and items which you will need in order to carry out certain work.

## 1.3 General information

- Service and maintenance work must be carried out taking this service manual into account.

- It is imperative that you observe safety information.
- Information about operation or about general maintenance and care work on the mobility device should be taken from service manual.
- You can find information about ordering spare parts in the spare parts catalogue.
- Spare parts must match original Invacare parts. Only use spare parts which have been approved by Invacare.
- We reserve the right to make any alterations on the grounds of technical improvements.
- For more information about the product, for example product safety notices and product recalls, contact your local Invacare representative. For address and website see back page of this manual.
- The mobility device may only be maintained and overhauled by qualified personnel.
- The minimum requirement for service technicians is suitable training, such as in the cycle or orthopedic mechanics fields, or sufficiently long-term job experience.
  - Experience in the use of electrical measuring equipment (multimeters) is also a requirement.
  - Special Invacare training is recommended.
- Alterations to the mobility device which occur as a result of incorrectly or improperly executed maintenance or overhaul work lead to the exclusion of all liability on the side of Invacare.
- If you have any problems or questions contact your provider.

## 1.4 Images in this manual

The detailed images in this manual are given marks to identify various components. Component marks in text and operational instructions always relate to the image directly above.

## 2 Safety

### 2.1 Safety information



**WARNING!**

The procedures in this service manual, must be performed by a specialized dealer or qualified service technician.

- Do not handle this product or any available optional equipment without first completely reading and understanding these instructions and any additional instructional material such as user manuals, installation manuals or instruction sheets supplied with this product or optional equipment.



The information contained in this document is subject to change without notice.

### 2.2 Safety notes on the electrical system



**WARNING!**

**Fire and burn hazard due to electrical shorts**

- The mobility device must be completely switched off before removal of voltage-carrying components. To do this, remove the batteries. For information about removing the batteries, refer to the service manual of the particular wheelchair.
- Avoid short-circuiting the contacts when carrying out measurements on voltage-carrying components.



**WARNING!**

**Risk of injury or damage due to electrical shorts**

Connector pins on cables connected to the power module can still be live even when the system is off.

- Cables with live pins should be connected, restrained or covered (with non-conductive materials) so that they are not exposed to human contact or materials that could cause electrical shorts.
- When cables with live pins have to be disconnected, for example, when removing the bus cable from the remote for safety reasons, make sure to restrain or cover the pins (with non-conductive materials).



**Risk of damage to the connector pins**

If you touch the connector pins, they can become dirty or they can be damaged by electrostatic discharge.

- Do not touch the connector pins.

To maximize performance, minimize EMC emissions, maximize EMC and ESD immunity, and to keep the cabling of the wheelchair safe and tidy, observe the following guidelines:

- All wiring should comply with the requirements of ISO7176-14.
- Keep all cables as short as possible.
- All cables used should be resistant to fire to VW-1 (UL 1581) or similar.
- Avoid wire loops, especially loops of single wires instead of wire pairs.
- Try to run wires in pairs or bunches. For example, run the battery's positive and negative wires together, and the motor's positive and negative wires together. Bind wires together and fix them to the chassis.
- Do not route the cables (including the motor cable) near the motor case, where possible.
- Make sure that all vehicle sub-frames, particularly the motors and controller case, are electrically connected.
- Do not use the vehicle frame as the earth return. Any electrical low-resistance connection to the frame is a safety risk and is not allowed by international safety standards.
- To minimize electromagnetic emissions by the motor brushes, it may be necessary to fit capacitors between the brush holders and the motor case. Make sure that the leads are kept as short as possible. A suitable capacitor is 4n7, 2kV Ceramic.
- For best electrical performance, the wire size must be as large as possible, but no larger than what the crimp in the connector can withstand. Always use the correct tool for crimping.
- Recommended minimum wire sizes are shown in the wiring sections.
- For low-current signals, do not use wire sizes smaller than 0.5 mm<sup>2</sup>/20 AWG, because smaller wires are physically not strong enough for this application.
- The type of cable used must be appropriate for the mechanical and environmental abuse it is likely to encounter.
- Do not use damaged or abused cables. A damaged cable can potentially produce localized heat, sparks or arcing, and as such it can cause a fire.
- Protect all cables against possible contact with flammable material.
- If an extension loom is fitted, mount it with the female connector facing horizontal or downwards, and protect it from direct splashing. If the extension loom is to be used for frequent disconnection, mount the female connector so that it faces downwards.

### 3 Assembly

#### 3.1 Tightening torques



**CAUTION!**

**Risk of damage to mobility device due to improperly tightened screws, nuts or plastic connections.**

- Always tighten screws, nuts etc. to the stated tightening torque.
- Only tighten screws or nuts which are not listed here fingertight.

The tightening torques stated in the following list are based on the thread diameter for the nuts and bolts for which no specific values have been determined. All values assume dry and de-greased threads.

Thread	Tightening torque in Nm ±10%
M4	3 Nm
M5	6 Nm
M6	10 Nm
M8	25 Nm
M10	49 Nm
M12	80 Nm
M14	120 Nm
M16	180 Nm

#### 3.2 Imperial to metric conversion chart

You can use this chart as an orientation to find the right tool size.

IMPERIAL	METRIC
inch	mm
5/64	1.9844
3/32	2.3813
7/64	2.7781
1/8	3.1750
9/64	3.5719
5/32	3.9688
11/64	4.3656
3/16	4.7625
13/64	5.1594
7/32	5.5563
15/64	5.9531
1/4	6.3500
17/64	6.7469
9/32	7.1438

IMPERIAL	METRIC
inch	mm
19/64	7.5406
5/16	7.9375
21/64	8.3344
11/32	8.7313
23/64	9.1281
3/8	9.5250
25/64	9.9219
13/32	10.3188
27/64	10.7156
7/16	11.1125
29/64	11.5094
15/32	11.9063
31/64	12.3031
1/2	12.7000
33/64	13.0969
17/32	13.4938
35/64	13.8906
9/16	14.2875
37/64	14.6844
19/32	15.0813
39/64	15.4781
5/8	15.8750
41/64	16.2719
21/32	16.6688
43/64	17.0656
11/16	17.4625
45/64	17.8594
23/32	18.2563
47/64	18.6531
3/4	19.0500
49/64	19.4469
25/32	19.8438
51/64	20.2406
13/16	20.6375
53/64	21.0344
27/32	21.4313
55/64	21.8281
7/8	22.2250

### 3.3 Overview Components

#### Remote modules

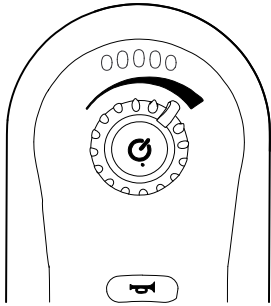

DLX-REM110

- Drive function

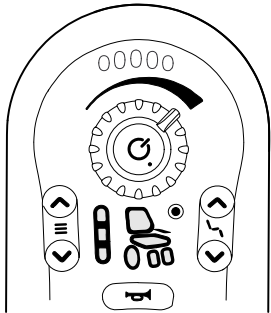

DLX-REM211

- Drive function
- Powered seating function

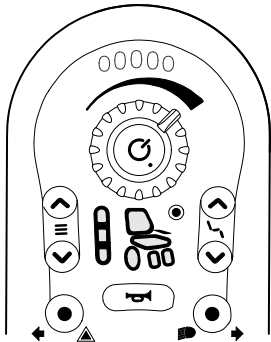

DLX-REM216

- Drive function
- Powered seating function
- Lighting function

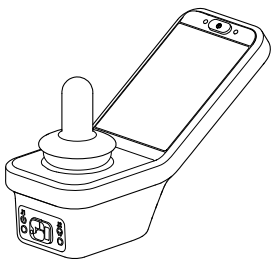

DLX-REM400

- Touch screen interface to facilitate:
  - Multiple drive functions
  - Multiple powered seating functions
  - Lighting function
- Multipurpose buttons
- 3.5 mm jack sockets

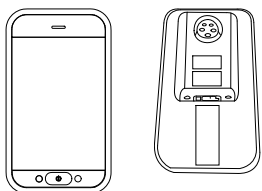

DLX-REM500

- Touch screen interface to facilitate:
  - Multiple drive functions
  - Multiple powered seating functions
  - Lighting function
- Multipurpose buttons
- 3.5 mm jack sockets

#### Secondary remote modules

LiNX IDC  
Intuitive Dual Control

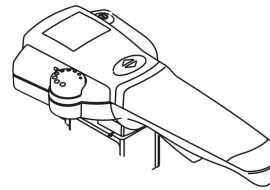

- On/Off button
- Speed dial
- Display for drive direction indicator

DLX-CR400  
Compact Remote

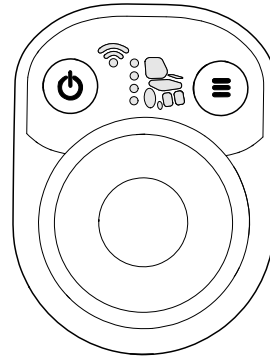

- On/Off button
- Menu button
- Display for drive, seating and connectivity functions

DLX-CR400LF  
Compact Remote Low Force

- As compact remote
- With low force joystick

DLX-ACU200  
Attendant Control Unit

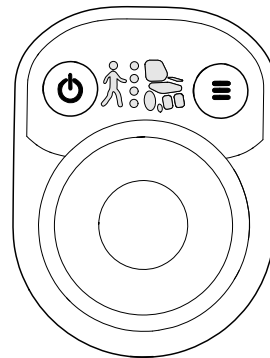

- On/Off respectively Select button
- Menu button
- Display for drive and seating functions and "who's in charge" indication

DLX-REM050

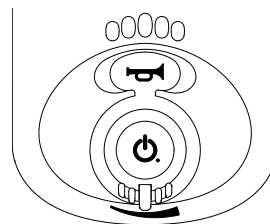

- Attendant control unit with drive function



**ASL components**



ASL 138  
Extremity Control Joystick

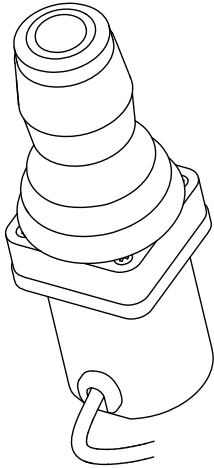

ASL 133  
Compact Single Switch Joystick

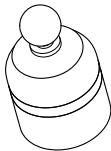

ASL 130  
Micro Extremity Control Joystick

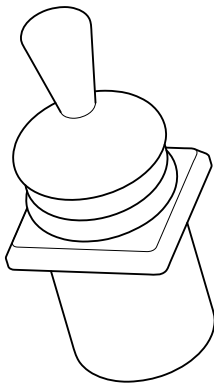

ASL 132  
Compact Joystick

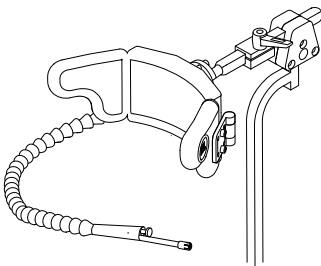

ASL 109  
Sip and Puff Head Array

**ASL components**

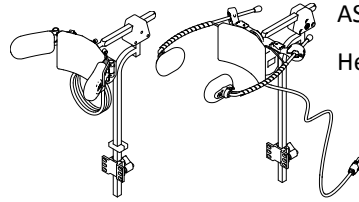

ASL 104/ASL 104P  
Head Array

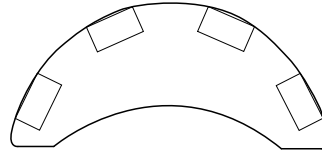

ASL 106  
Four Switch Proximity Array

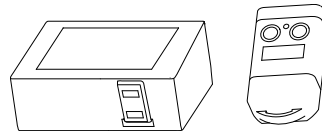

ASL 504  
Remote Stop Switch

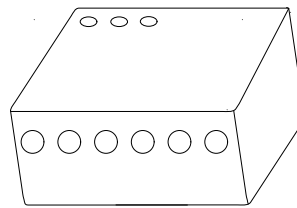

Wireless Accessories for ATOM:

- Wireless Mouse Emulator ASL 558
- Wireless Triple Switch Receiver ASL 557-3

**Power modules**

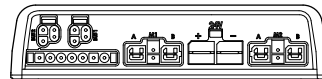

DLX-PM60

- 63 A maximum current
- 2 x bus sockets
- Dynamic Load Compensation
- Adaptive Load Compensation
- Utility port
- Real-time clock

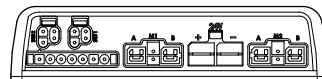

DLX-PM75

- 78 A maximum current
- 2 x bus sockets
- Dynamic Load Compensation
- Adaptive Load Compensation
- Utility port
- Real-time clock

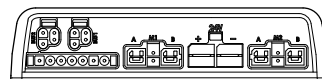

DLX-PM120

- 120 A maximum current
- 2 x bus sockets
- Dynamic Load Compensation
- Adaptive Load Compensation
- Utility port
- Real-time clock

**Power modules**

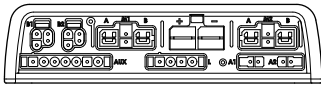

**DLX-PM75AL**

- 78 A maximum current
- 2 x bus sockets
- Dynamic Load Compensation
- Adaptive Load Compensation
- Utility port
- 2 x actuators
- 3 x lights
- Real-time clock

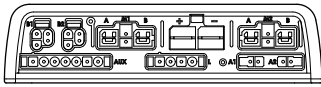

**DLX-PM120AL**

- 120 A maximum current
- 2 x bus sockets
- Dynamic Load Compensation
- Adaptive Load Compensation
- Utility port
- 2 x actuators
- 3 x lights
- Real-time clock

**LiNX seating modules and interfaces**

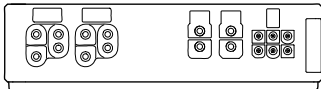

**DLX-ACT200**

- 2 x actuator channels
- 2 x bus ports
- 1 x 6-pin general purpose input (GPI) port
- Module status LED
- Actuator power provided through the bus

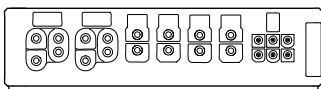

**DLX-ACT400**

- 4 x actuator channels
- 2 x bus ports
- 1 x 6-pin general purpose input (GPI) port
- Module status LED
- Actuator power provided through the bus

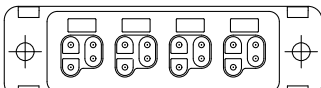

**GLM-CONX4**

4-way connector

- Expansion block to connect to additional, multiple modules in a LiNX system

**LiNX seating modules and interfaces**

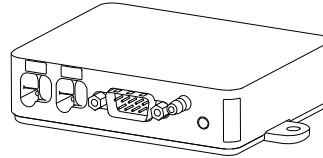

**DLX-IN500**  
Input module

- DB9 connector for proportional and switched inputs
- 12 V (200 mA) power supply
- Sip and puff nozzle
- Jack input (stereo)
- 2 x LiNX bus connector
- Activity indicator displaying input demands

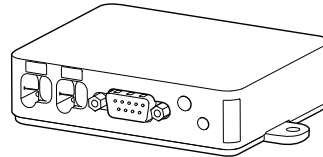

**DLX-OUT500**  
Output module

- DB9 connector for switched outputs
- Jack output (stereo)
- 2 x LiNX bus connector
- Status indicator

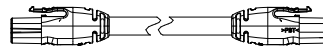

Bus cable; length from 300 up to 2500 mm

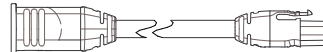

Extension loom; length 640 and 900 mm

**Powered seating accessories**

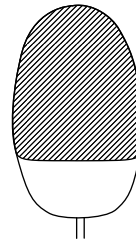

**ASL300**  
Egg switch

- Momentary switch
- Normally open
- Mono jack

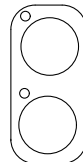

Stereo button switch

- 2 switches
- Stereo jack



Stereo toggle switch

- Toggle switch
- Normally open
- Stereo jack

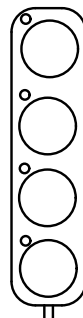

4-way button switch

- 4 switches
- DB9 connector

**Powered seating accessories**

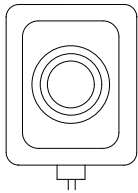

- 4-way toggle switch
- 4 toggle directions
  - DB9 connector

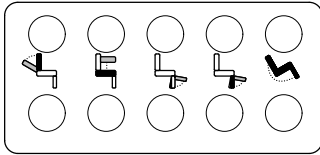

- 10-way switch
- Hardware-only module that provides simple, direct access to powered seating functions

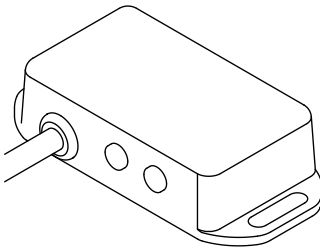

- DLX-FKEY01
- For systems with one physical actuator
  - Powered seating control through egg switch, stereo button switch or stereo toggle switch

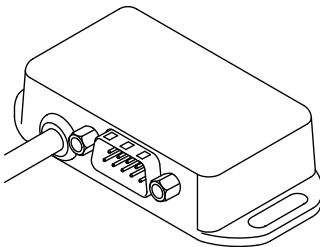

- DLX-FKEY02
- For systems with two or more physical actuators
  - Powered seating control through 4-way button switch or 4-way toggle switch



- DLX-GYR100  
LiNX G-Trac module
- stabilizes wheelchair's driving behavior



- DLX-USB02  
LiNX USB charger
- 2 USB charger ports
  - 1 A charging current per port
  - Protective rubber bungs

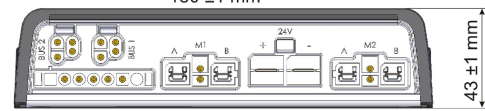

**DLX-PM75AL, DLX-PM120AL**

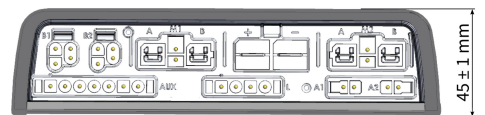
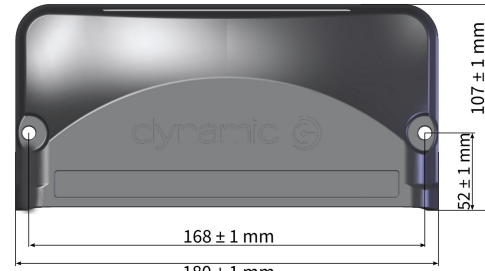

**Correct mounting**

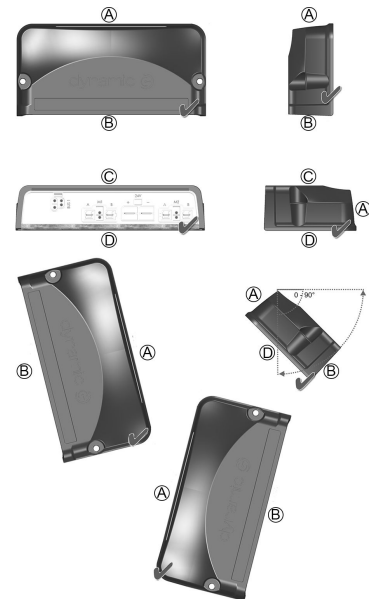

- Ⓐ Rear
- Ⓑ Connectors
- Ⓒ Top
- Ⓓ Base

The power modules can be placed on its side or at an angle. When placing the power modules at an angle, ensure that the connectors Ⓑ facing downwards, so that the connector recesses will not collect or retain foreign matter or liquids.

**3.4 Power module mounting**

The mounting orientation of the power module that is specified by Invacare per wheelchair model must be kept.

**Dimensions of the power modules**

**DLX-PM60, DLX-PM75, DLX-PM120**

**Incorrect mounting**

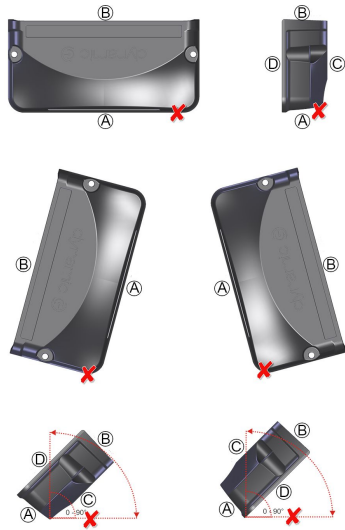

- Ⓐ Rear
- Ⓑ Connectors
- Ⓒ Top
- Ⓓ Base

**Testing**

The LiNX system must be fully tested after all modules and cables have been installed.

**3.5 Mounting positions on wheelchairs**

 The positions of the power modules Ⓐ and DLX-ACT200/400 Ⓑ depending on wheelchair model and —configuration are shown in the table below. For further information about access to the components, refer to the Service manual of the particular wheelchair model.

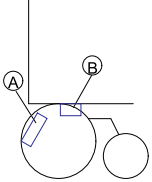
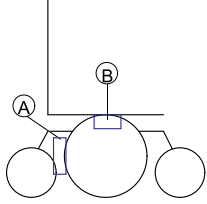
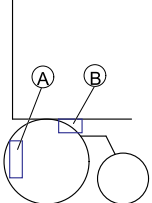
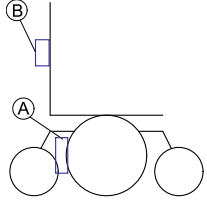
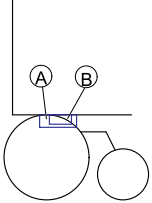
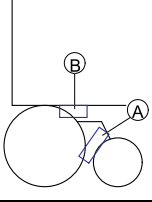
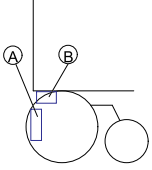
Rear Wheel Drive		Center Wheel Drive	
Fox		TDX SP2, TDX SP2 narrow base, TDX SP2 wide base with Modulite seat	
Kite, Kite HD		TDX SP2 narrow base and TDX SP2 wide base with Ultra Low Maxx seat	
Bora/Spectra XTR, Spectra XTR HD w/o lifter/tilt module			
Bora/Spectra XTR, Spectra XTR HD w lifter/tilt module			
Storm <sup>4</sup> , Storm <sup>4</sup> X-plore, Storm <sup>4</sup> Max <sup>1</sup>			

1 no DLX-ACT200/400 on Storm<sup>4</sup> Max

### 3.6 Port pin-outs

DLX-PM60, DLX-PM75, DLX-PM120

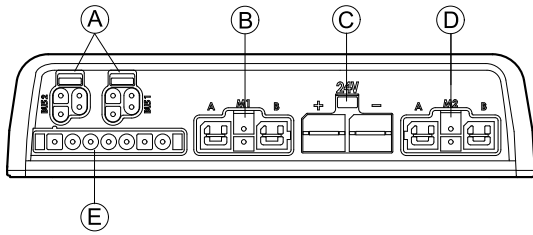

- Ⓐ LiNX communication bus
- Ⓑ Motor / park brake port M1
- Ⓒ Battery port
- Ⓓ Motor / park brake port M2
- Ⓔ Utility port

DLX-PM75AL, DLX-PM120AL

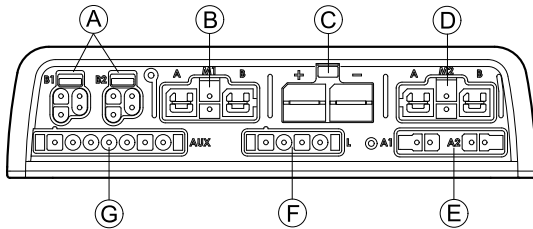

- Ⓐ LiNX communication bus
- Ⓑ Motor / park brake port M1

- Ⓒ Battery port
- Ⓓ Motor / park brake port M2
- Ⓔ Actuator ports
- Ⓕ Lighting port
- Ⓖ Utility port

### 3.7 Actuator Port Configurations (Factory Setup)

Actuator ports, properties and behavior per actuator are defined by Invacare. You can change speed, direction and operation mode. This is done in different menus, refer to *8.8 Modifying Seating Parameters, page 74*.

#### Seating Motion







The seating movement is called seating motion. The seating motion defines the icon displayed on the user interface, overall speed, the individual actuators and their speeds. A seating motion can control one or more actuators. There are six seating motions defined in the factory set-up.

#### Seating Function

The seating function is the user input and defines how the motion is operated.

The “AL” power modules that feature actuators and lights, have two actuator ports. If required, the system is completed with the DLX-ACT200 or DLX-ACT400, based on the configuration. The following chapters detail the port set-up per module/configuration.

### 3.7.1 Port configurations for systems with DLX-REM2xx (EU-Version with Modulite seat)

Channel	Seating motion (Icon)	Seating function (Operation)
Ⓐ	Tilt 	Proportional FWD/REV
Ⓑ	Recline 	Proportional FWD/REV
Ⓒ	Right leg 	Proportional FWD/REV
Ⓓ	Left leg/ Center-mounted legrest 	
Both legs 		Proportional FWD/REV
Ⓔ	Lifter 	Proportional FWD/REV

#### Port configuration without lifter

Power module

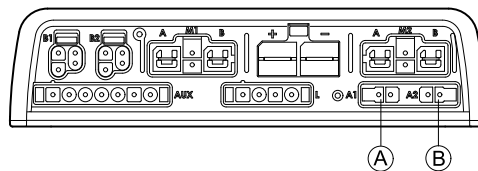

DLX-ACT200

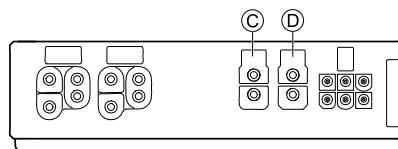

DLX-ACT400

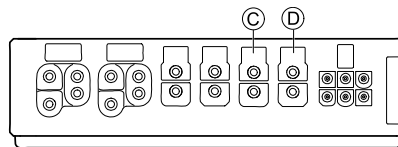

**Port configuration with lifer**

Power module

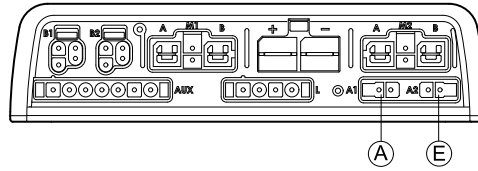

DLX-ACT200

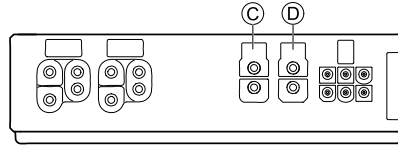

DLX-ACT400

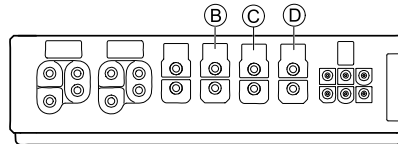



**3.7.2 Port configuration for non-expandable systems (US version)**



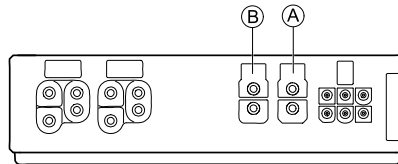







Non-expandable systems are fitted with external switches and a functionkey, to control the powered seating functions. For more information about functionkeys, refer to chapter 3.7.4 *Port Configurations for Functionkeys*, page 17.

**Single actuator systems**







Channel	Seating motion (Icon)	Seating function (Operation)
Ⓐ	Recline only 	Proportional FWD/REV
Ⓑ	Tilt only 	Proportional FWD/REV
Ⓑ	LNx only 	Proportional FWD/REV

Two actuator systems

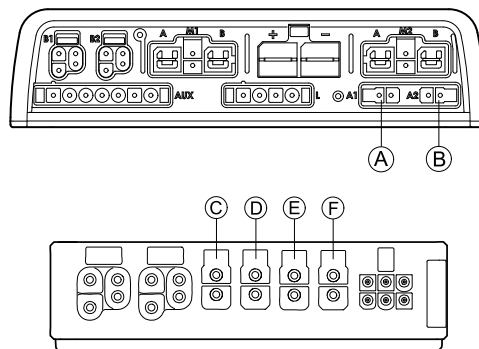

Channel	Seating motion (Icon)	Seating motion (Icon)	Seating motion (Icon)	Seating motion (Icon)	Seating motion (Icon)	Seating function (Operation)
Ⓐ	Tilt 	Tilt 	Recline 	Left leg 	Recline 	Proportional FWD/REV
Ⓑ	Lifter 	LNx 	LNx 	Right leg 	Tilt 	Proportional FWD/REV

3.7.3 Port configuration for systems with DLX-REM400 and DLX-REM500 (with Ultra Low Maxx seat)



Channel	Seating motion (Icon)	Seating function (Operation)
Ⓐ	Tilt 	Proportional FWD/REV
Ⓑ	Lifter 	Proportional FWD/REV
Ⓒ	Legrest right 	Proportional FWD/REV
Ⓓ	Legrest left 	Proportional FWD/REV



Channel	Seating motion (Icon)	Seating function (Operation)
Ⓔ	LNX 	Proportional FWD/REV
Ⓕ	Recline 	Proportional FWD/REV

### 3.7.4 Port Configurations for Functionkeys

If the system is installed with an external switch, to control the powered seating functions (except a 10 way switch), a functionkey is required to interface the switches. There are two different configurations of functionkeys. The type of functionkey determines the behavior of the system in regards to the control of actuators. Properties and behavior per switch are defined by Invacare and can be reassigned via the port to which the control input is connected. Reassigning is done in the **CONTROL INPUTS/OUTPUTS** section of the respective module. See *10.11 Programming external switches, page 102*

#### Type 1: Single Actuator System (SAS)

This functionkey is for systems with one physical actuator. It is available in one configuration:

- FKEY01TDC: actuator control through switches and joystick

External switches to control the powered seating functions, must be plugged into the Jack sockets, see table below.

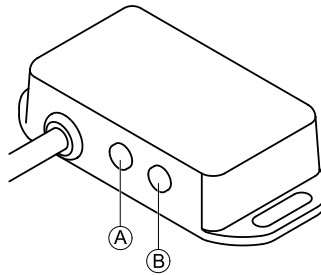

- Ⓐ Mono jack to connect egg switch
- Ⓑ Stereo jack to connect stereo button switch or stereo toggle switch

#### Type 2: Multi-Actuator System (MAC)

This functionkey is for systems with two or more physical actuators. It is available in one configuration:

- FKEY02TDC: actuator control through switches and joystick

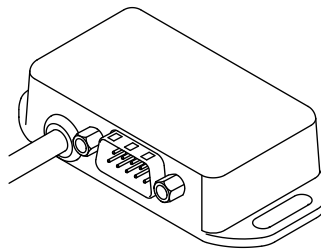

The 4-way button switch or the 4-way toggle switch must be plugged into the DB9 socket.

## 3.8 Wiring Diagrams

 The following diagrams show the wiring for a wheelchair in a complex configuration including multiple actuators, lights and attendant control unit.

 To identify the required cable length, see tables below or measure the cable after removing it.

**Wiring for configurations of Modulite seat with lifter, tilt, recline, powered elevating legrests, lights, attendant control unit, secondary remote, DLX-ACT400 and USB charger**

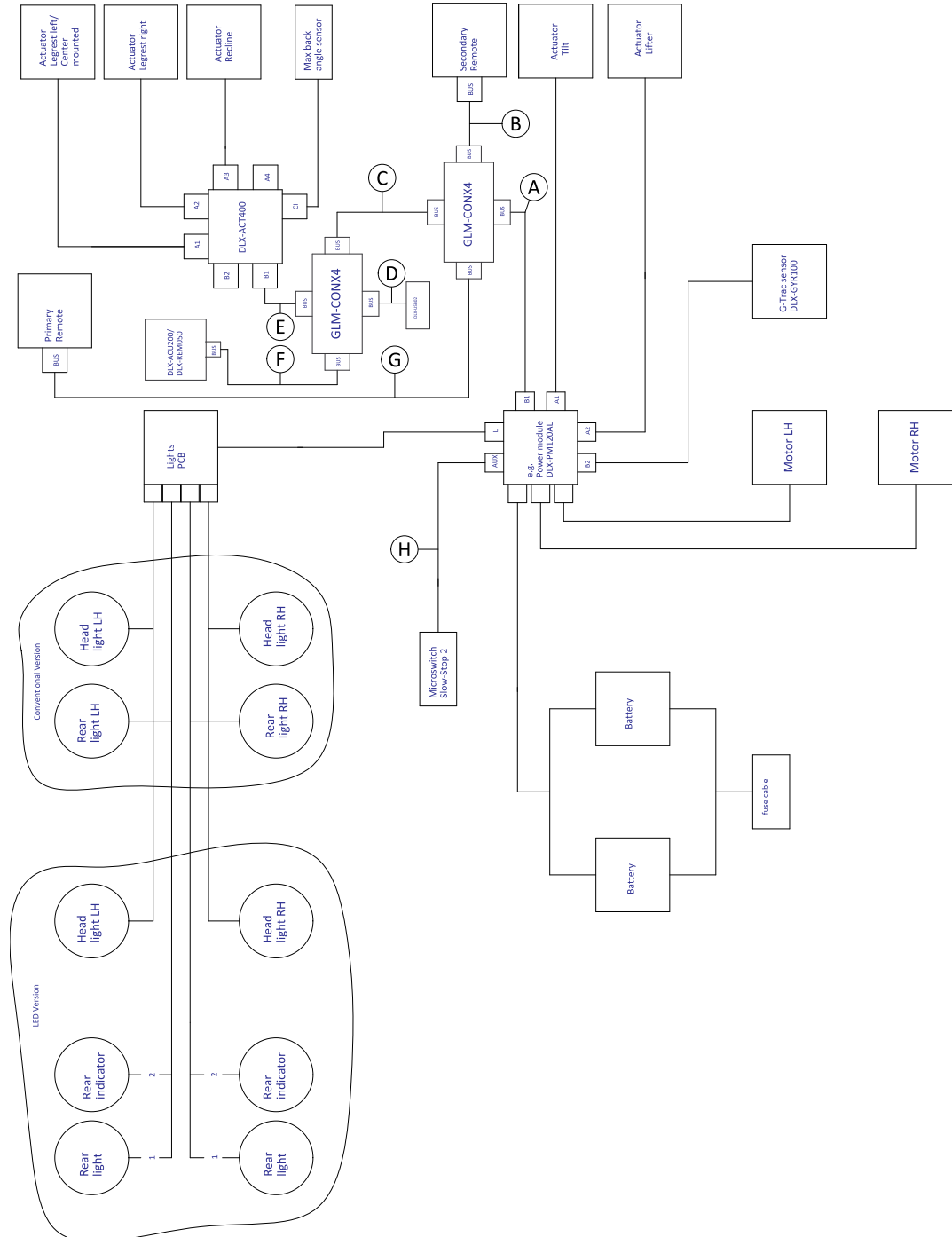

Fig. 3-1

**i** Cable length may vary depending on mounting positions of primary and secondary remotes and of 4-way connector GLM-CONX4.

Model	A	B	C	D	E	F	G	H
Kite	2500 mm	1500 mm	300 mm	700 mm	700 mm	1500 mm	1700 mm	700 mm
Spectra XTR <sup>2</sup> HD, Bora/Spectra XTR Standard	1700 mm	1700 mm	300 mm	700 mm	700 mm	1200 mm	1500 mm	700 mm
TDX SP2	1500 mm	1200 mm	300 mm	300 mm	700 mm	1000 mm	1200 mm	300 mm
Storm <sup>4</sup> , Storm <sup>4</sup> X-plore	1500 mm	1200 mm	300 mm	500 mm	300 mm	1200 mm	1500 mm	300 mm

**Wiring for configurations of Modulite seat with lifter, tilt, recline, powered elevating legrests, lights, attendant control unit, DLX-ACT400 and USB charger**

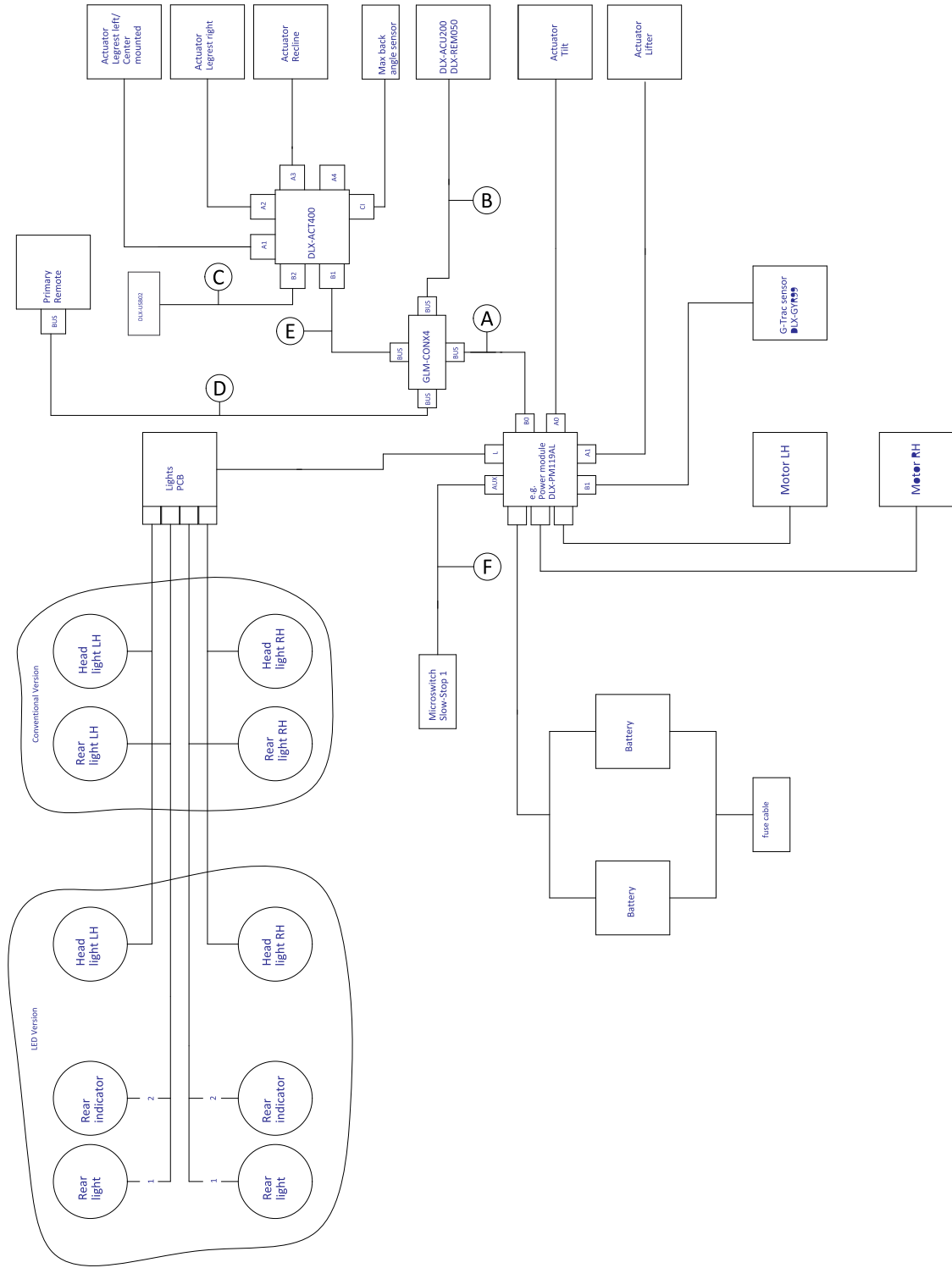

Fig. 3-2



Cable length may vary depending on mounting positions of primary and secondary remotes and of 4-way connector GLM-CONX4.

Model	A	B	C	D	E	F
Kite	2500 mm	1500 mm	700 mm	1700 mm	700 mm	700 mm
Spectra XTR <sup>2</sup> HD, Bora/Spectra XTR Standard	1700 mm	1200 mm	700 mm	1500 mm	700 mm	700 mm

<b>Model</b>	<b>Ⓐ</b>	<b>Ⓑ</b>	<b>Ⓒ</b>	<b>Ⓓ</b>	<b>Ⓔ</b>	<b>Ⓕ</b>
TDX SP2	1500 mm	1000 mm	300 mm	1500 mm	700 mm	300 mm
Storm <sup>4</sup> , Storm <sup>4</sup> X-plore	1500 mm	1200 mm	500 mm	1500 mm	300 mm	300 mm

**Wiring for configurations of Modulite seat with tilt, recline, powered elevating legrests, lights and DLX-ACT200**

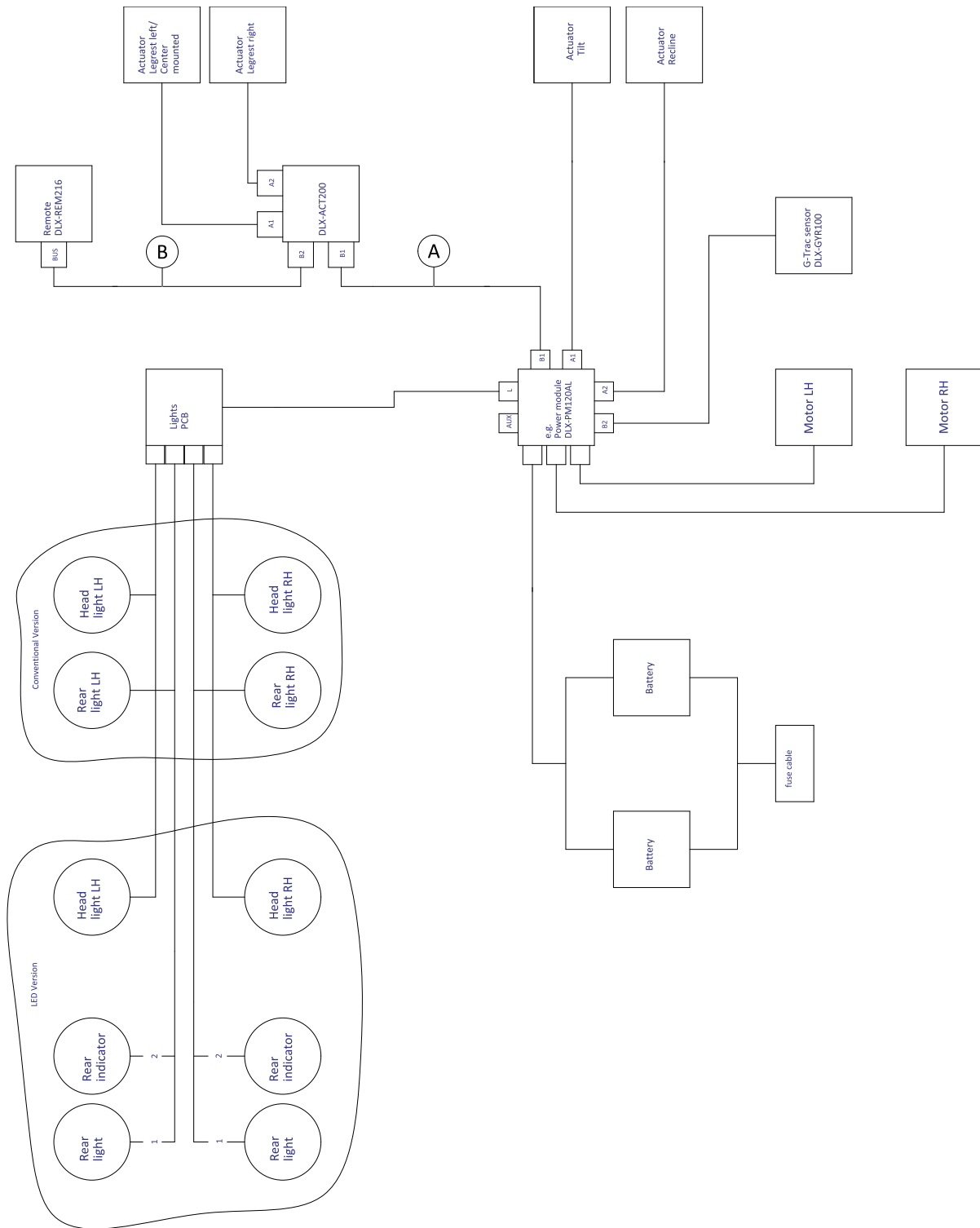

Fig. 3-3

**i** Cable length may vary depending on mounting positions of primary and secondary remotes.

Model	A	B
Kite	1500 mm	1500 mm
Spectra XTR <sup>2</sup> HD, Bora/Spectra XTR Standard	1500 mm	1500 mm
TDX SP2	1700 mm	1000 mm
Storm <sup>4</sup> , Storm <sup>4</sup> X-plore	1200 mm	1500 mm

**Wiring for Drive only configuration of Modulite seat**

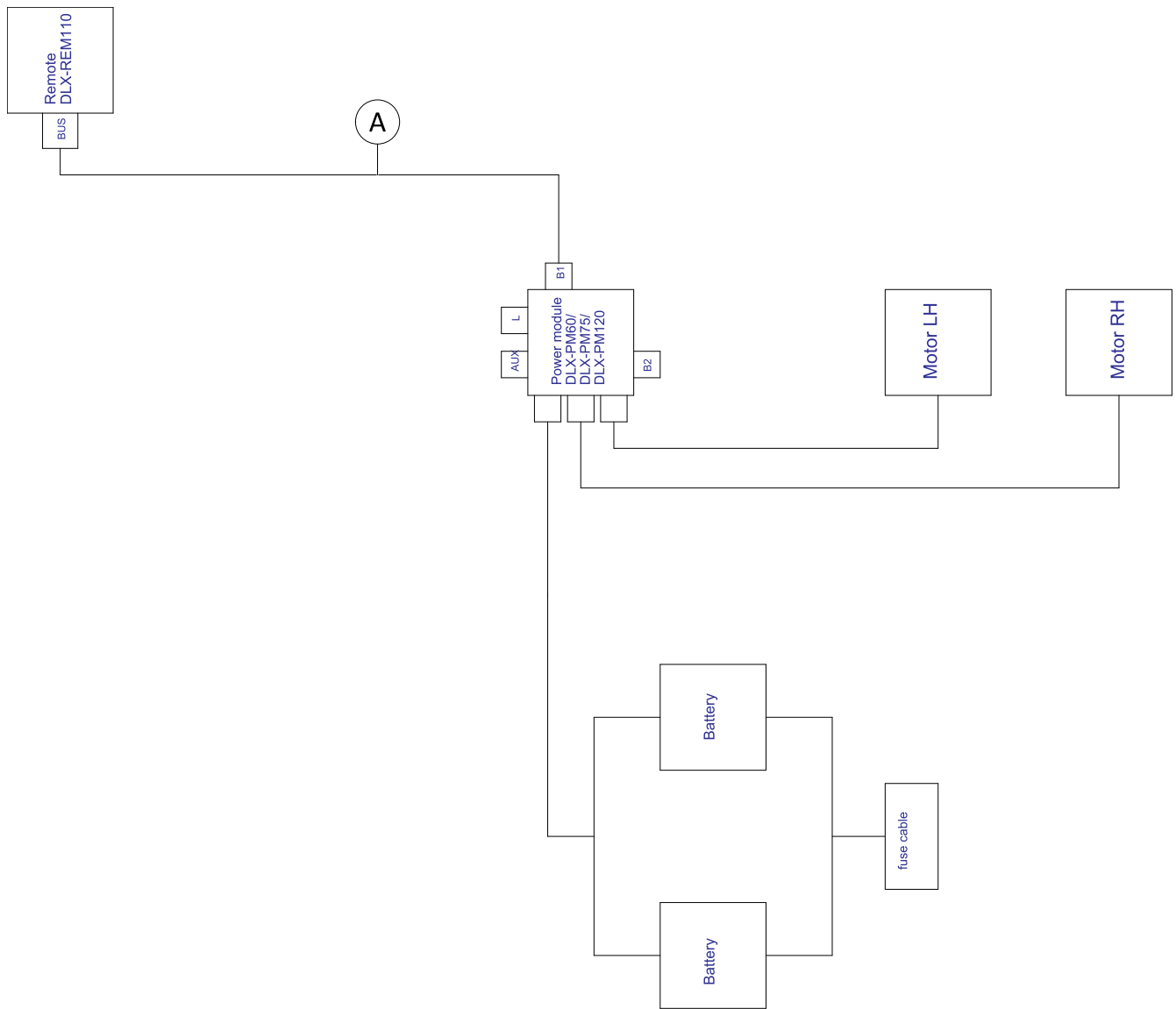



Fig. 3-4

 Cable length may vary depending on mounting positions of primary remote.

Model	Ⓐ
Kite	2000 mm
Spectra XTR <sup>2</sup> HD, Bora/Spectra XTR Standard	2000 mm
TDX SP2	1500 mm
Storm <sup>4</sup> , Storm <sup>4</sup> X-plore	2000 mm
Fox	1000 mm + 640 mm extension loom

Wiring for Fox with Modulite Drive only with ACU

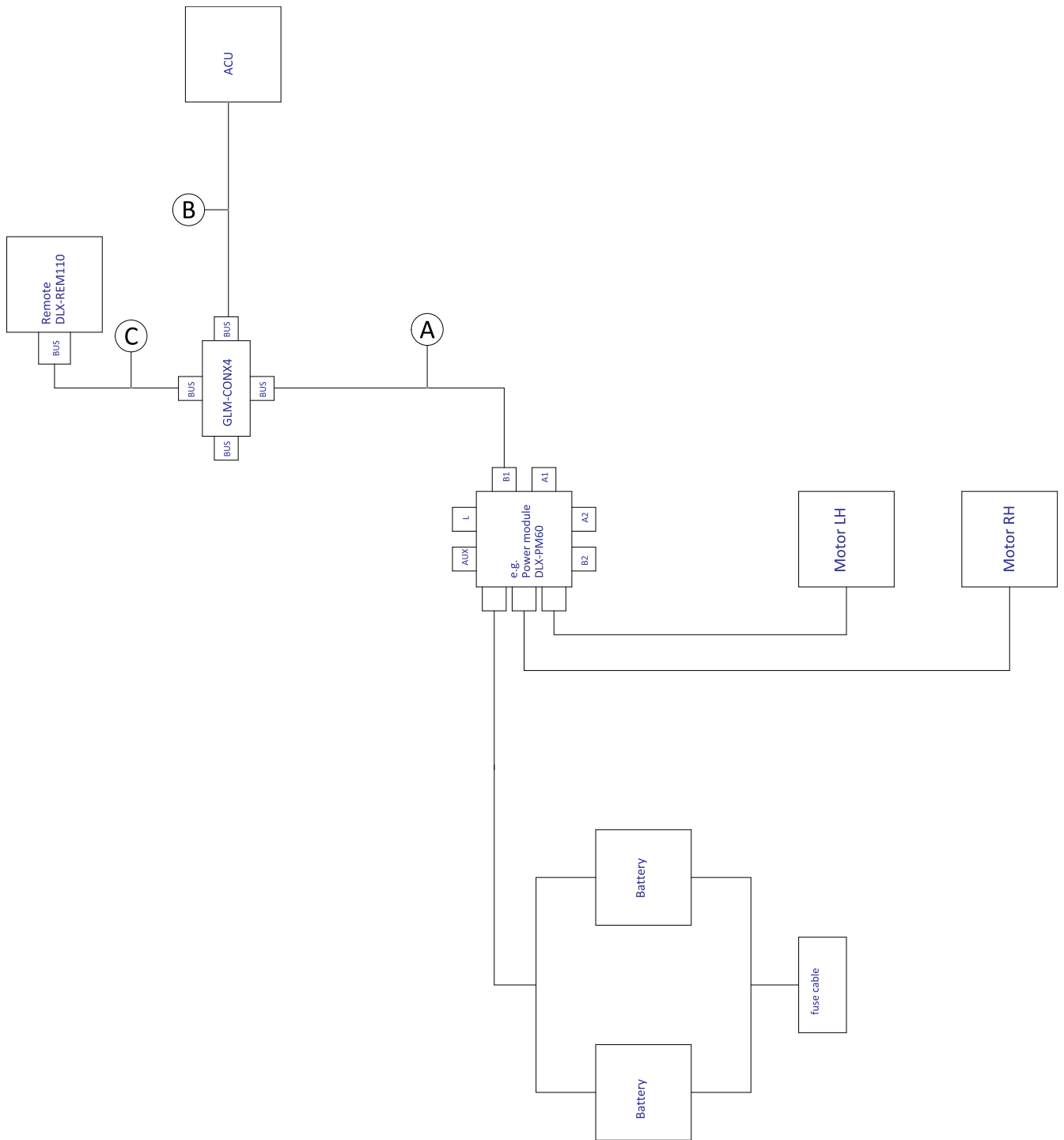

Fig. 3-5

**i** Cable length may vary depending on mounting positions of primary and secondary remotes and of 4-way connector GLM-CONX4.

Ⓐ	300 mm + 640 mm extension loom
Ⓑ	1000 mm
Ⓒ	1000 mm

Wiring for Fox with Modulite Recline only

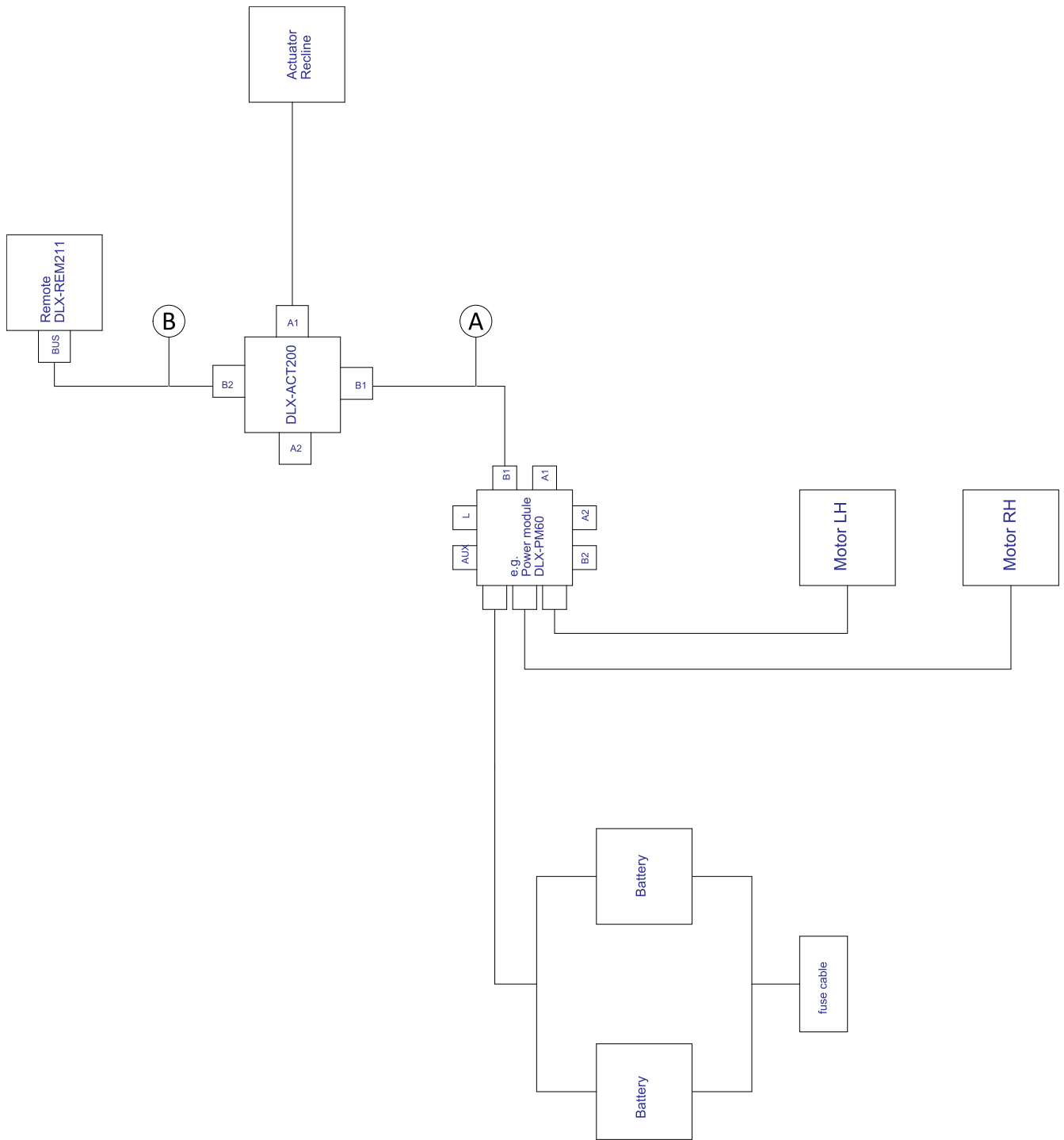



Fig. 3-6

 Cable length may vary depending on mounting positions of primary remote.

Ⓐ	300 mm + 640 mm extension loom
Ⓑ	1000 mm



**Wiring for Fox with Modulite Recline only and ACU**

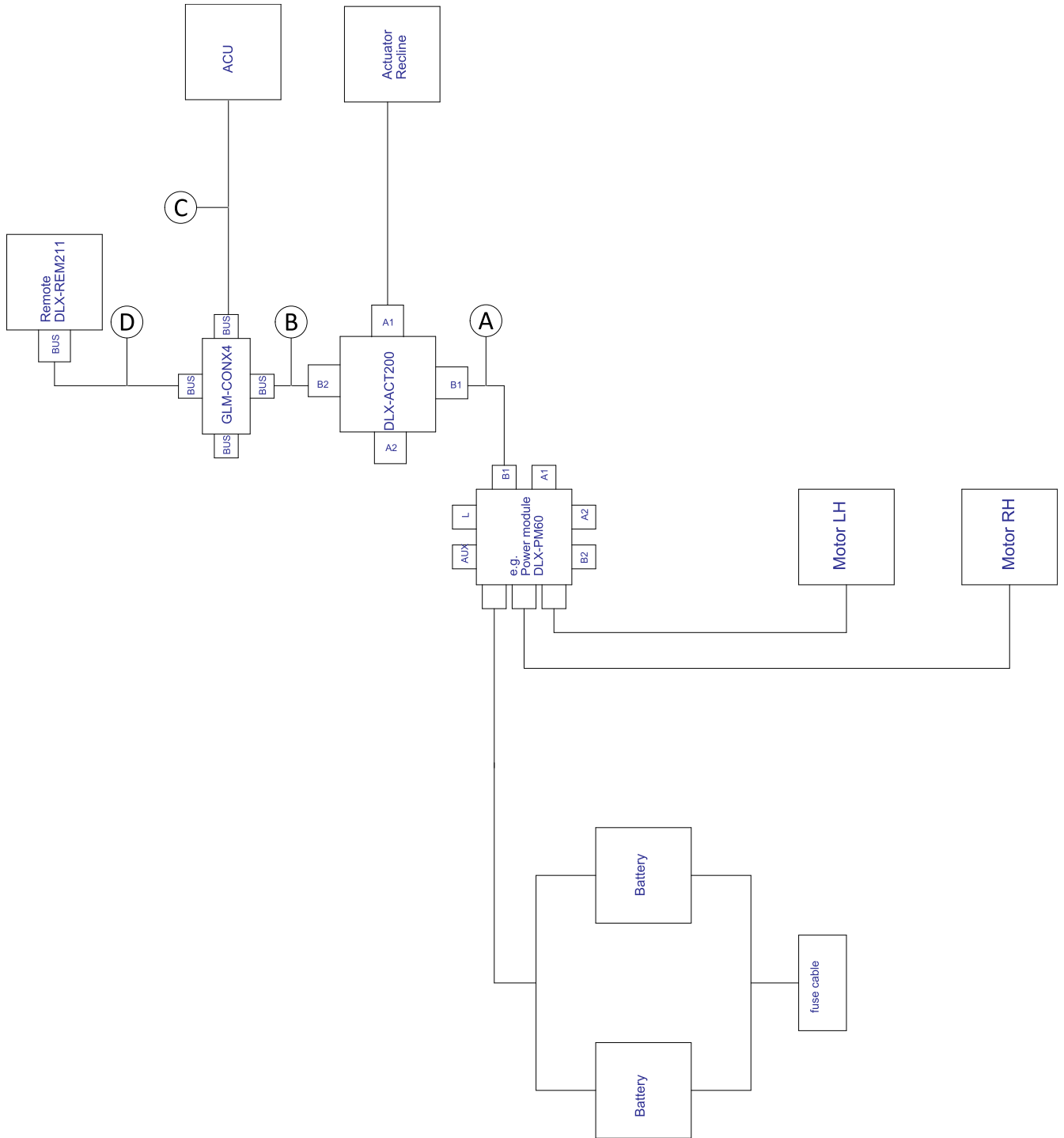

Fig. 3-7

**i** Cable length may vary depending on mounting positions of primary and secondary remotes and of 4-way connector GLM-CONX4.

Ⓐ	300 mm + 640 mm extension loom
Ⓑ	500 mm
Ⓒ	1000 mm
Ⓓ	1000 mm

Wiring for Non expandable systems with Ultra Low Maxx seat (US only)

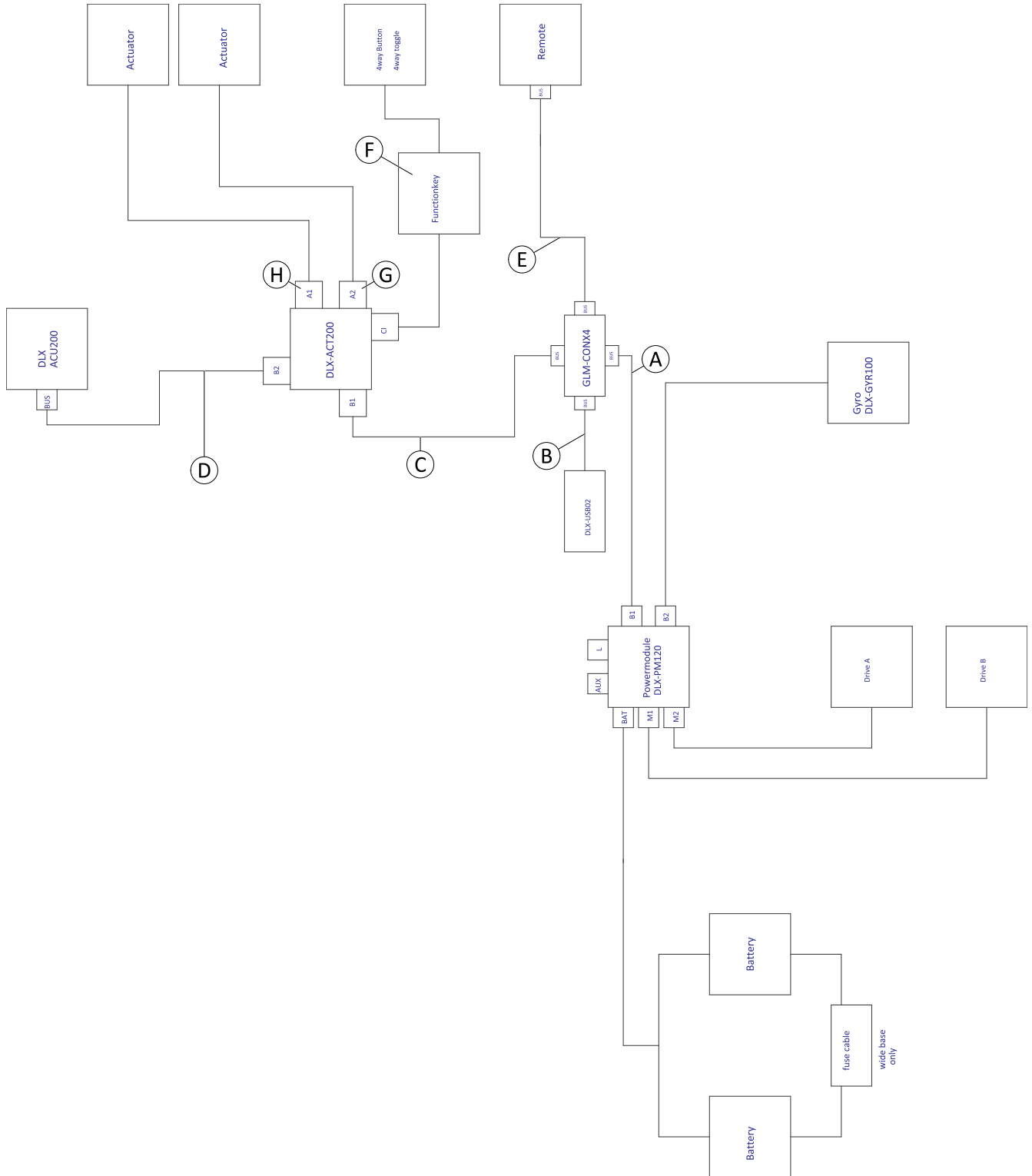



Fig. 3-8

 Cable length may vary depending on mounting positions of primary and secondary remotes and of 4-way connector GLM-CONX4.

Configuration	A	B	C	D	E	F	G	H
Recline only	1200 mm	300 mm	700 mm	300 mm	1500 mm	Functionkey FKEY01/ FKEY01TDC	not used	Recline connected
Tilt /Recline	1200 mm	300 mm	700 mm	300 mm	1500 mm	Functionkey FKEY02/ FKEY02TDC	Tilt connected	Recline connected
LNX only	1200 mm	300 mm	1200 mm	300 mm	1500 mm	Functionkey FKEY01/ FKEY01TDC	LNX connected	not used
Tilt only	1200 mm	300 mm	1200 mm	300 mm	1500 mm	Functionkey FKEY01/ FKEY01TDC	Tilt connected	not used
Dual legs	1200 mm	300 mm	1200 mm	300 mm	1500 mm	Functionkey FKEY02/ FKEY02TDC	Legrest right connected	Legrest left connected
Recline/LNX	1200 mm	300 mm	1200 mm	300 mm	1500 mm	Functionkey FKEY02/ FKEY02TDC	LNX connected	Recline connected
Tilt/LNX	1200 mm	300 mm	1200 mm	300 mm	1500 mm	Functionkey FKEY02/ FKEY02TDC	LNX connected	Tilt connected
Tilt/Lifter	1200 mm	300 mm	1200 mm	300 mm	1500 mm	Functionkey FKEY02/ FKEY02TDC	Lifter connected	Tilt connected

Wiring for configurations with Ultra Low Maxx seat

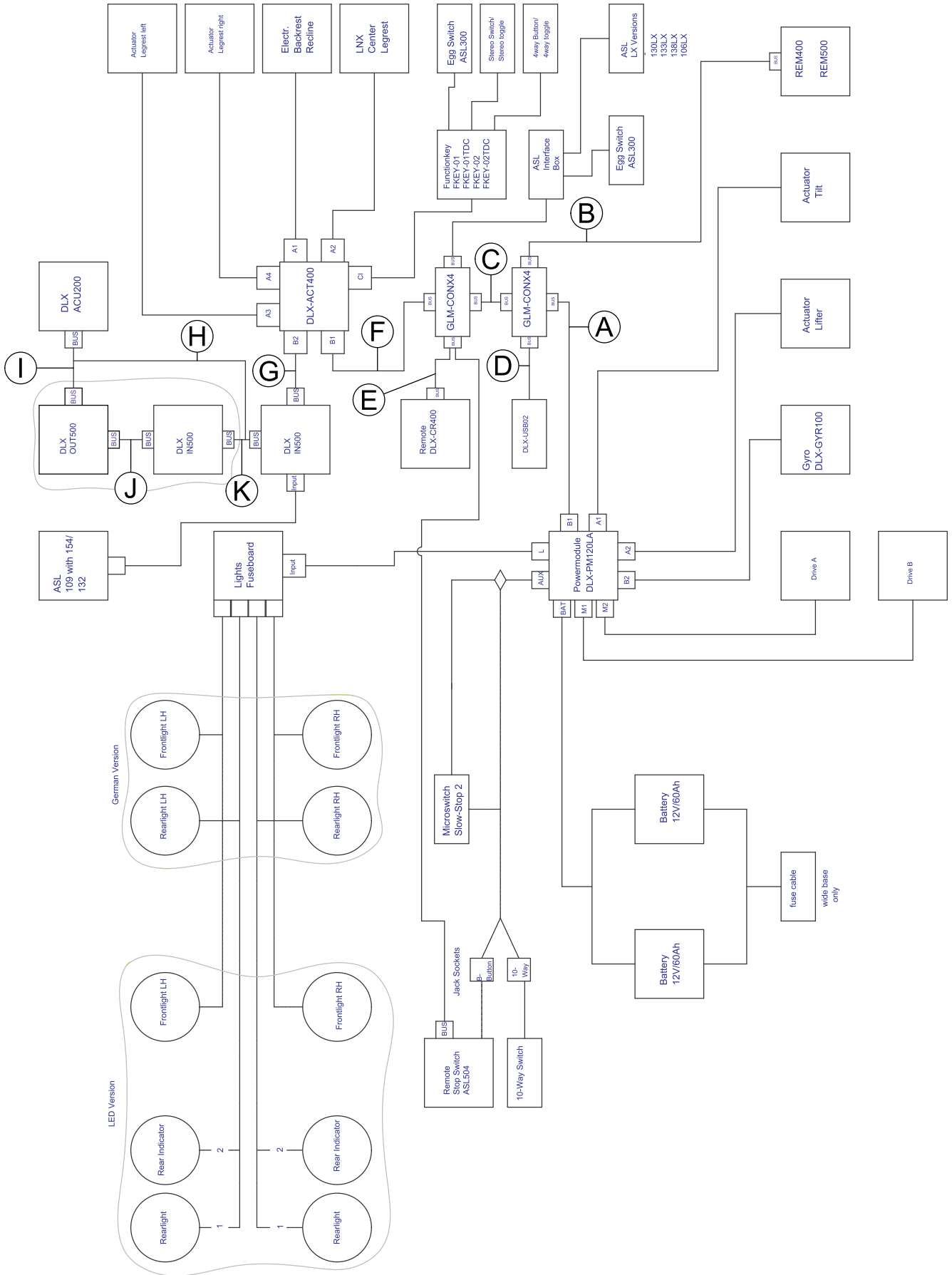



Fig. 3-9

 Cable length may vary depending on mounting positions of primary and secondary remotes and of 4-way connector GLM-CONX4.

 Depending on configuration, the Egg switch ASL300 can be connected to the primary remote.

Configuration	w tilt, w recline, w/o lifter	w tilt, w/o recline, w/o lifter	w tilt, w recline, w lifter	w tilt, w/o recline, w lifter
Ⓐ	1200 mm	1200 mm	1500 mm	1500 mm
Ⓑ	1500 mm	1700 mm	1700 mm	1700 mm
Ⓒ	700 mm	1200 mm	700 mm	1200 mm
Ⓓ	300 mm	300 mm	300 mm	300 mm
Ⓔ <sup>1</sup>	1700 mm	1200 mm	1200 mm	1200 mm
Ⓕ	300 mm	300 mm	300 mm	300 mm
Ⓖ	300 mm	300 mm	300 mm	300 mm
Ⓗ	300 mm	300 mm	300 mm	300 mm
Ⓘ	300 mm	300 mm	300 mm	300 mm
Ⓙ	300 mm	300 mm	300 mm	300 mm
Ⓚ	300 mm	300 mm	300 mm	300 mm



<sup>1</sup> Bus port either for DLX-CR400 or for Remote Stop Switch. Cannot be combined.

### 3.9 Mounting the primary remotes

 For more information about how remote holders are mounted to the wheelchair, refer to the service manual of the seating system.

#### 3.9.1 Mounting DLX-REM1XX and DLX-REM2XX for Modulte

##### Standard remote holder

-  • 3 mm Allen key
-  • 8 mm wrench

1.

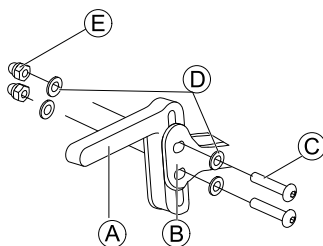

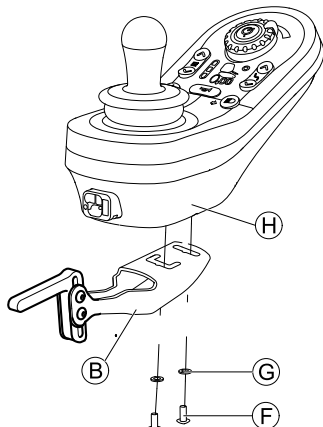

Mount joystick holder **A** to remote adapter **B** with screws **C**, washers **D** and nuts **E**.

2.



Mount remote **H** to remote adapter **B** with screws **F** and washers **G**.

##### Swing away remote holder

-  • 4 mm Allen key
-  • 3 mm Allen key
-  • 8 mm wrench
-  • 10 mm wrench

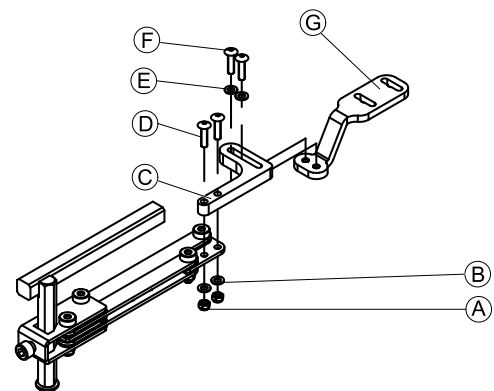

1. Pull screws **D** through bracket **C**, remote holder and washers **B**.
2. Tighten screws with nuts **A**.

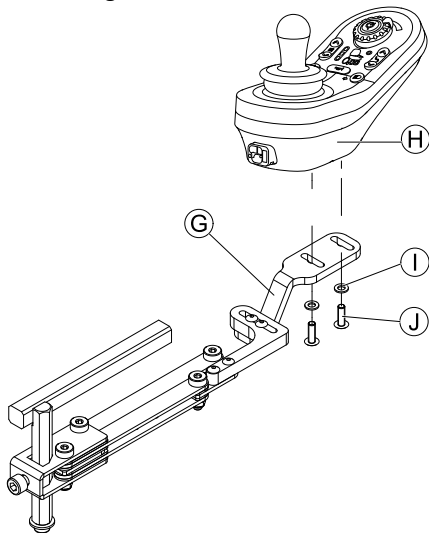

3. Pull screws ⑥ through washers ⑤, bracket ③ and bracket ④ and tighten screws.
- 4.



Tighten remote ⑧ with screws ⑩ and washers ⑨ to bracket ③.

### Remote holder for attendant

The remote is fitted to the wheelchair using a bracket on the push handle or the push bar.

-  • 4 mm Allen key
-  • 3 mm Allen key

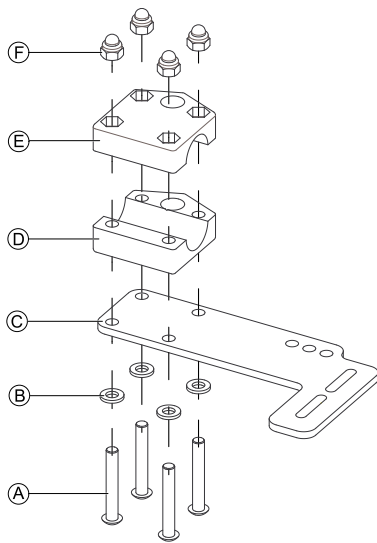

1. Pull screws ① through washers ②, mounting plate ③ and bottom side of bracket ④.
2. Tighten bottom side of the bracket to push bar with the top side of the bracket ⑤ and nuts ⑥.
- 3.

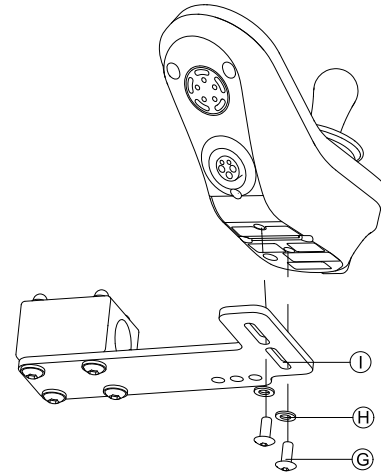



Fix remote to bracket ⑩ with screws ③ and washers ④.

For mounting positions, refer to 3.10.4 *Mounting the DLX-REM050*, page 37.

### 3.9.2 Mounting DLX-REM2XX for Ultra Low Maxx

#### Standard remote holder

-  • 3 mm Allen key
-  • 8 mm wrench

- 1.

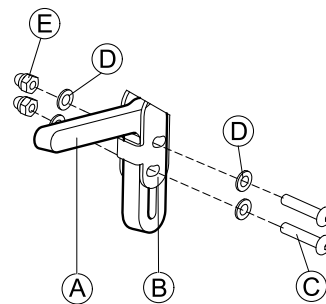

Mount joystick holder ① to remote adapter ② with screws ③, washers ④ and nuts ⑤.

- 2.

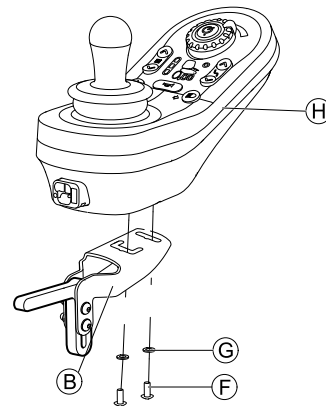

Mount remote ⑧ to remote adapter ② with screws ⑥ and washers ⑦.

### Swing away remote holder



- 3 mm Allen key
- 4 mm Allen key
- 8 mm wrench
- 10 mm wrench

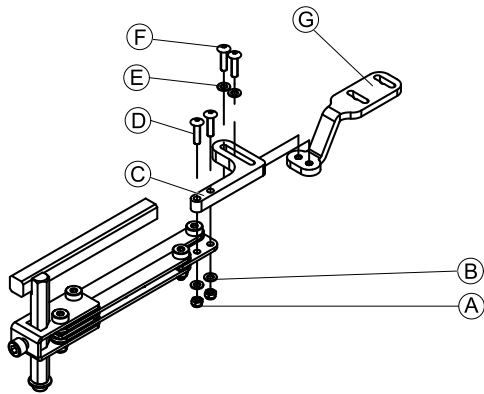

1. Pull screws ④ through bracket ③, remote holder and washers ②.
2. Tighten screws with nuts ①.
3. Pull screws ⑥ through washers ⑤, bracket ③ and bracket ④ and tighten screws.
- 4.

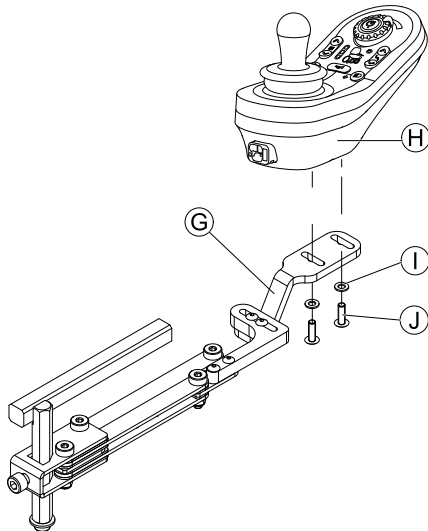

Tighten remote ⑧ with screws ⑩ and washers ⑪ to bracket ③.

### Quad Link remote holder



- 3 mm Allen key
- 5 mm Allen key

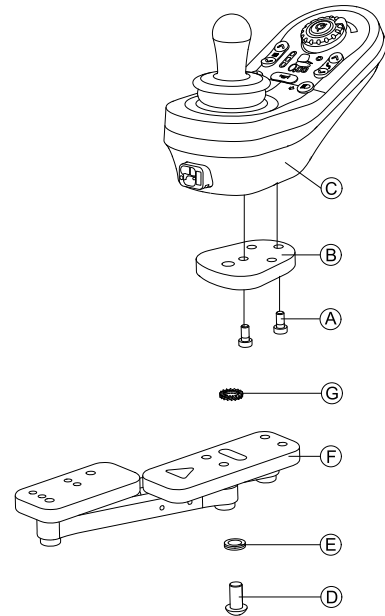

1. Mount LiNX remote adapter ② with screws ① to remote ③.
  - ! The LiNX remote adapter can be turned 90° right or left for more adjustment options.
2. Mount remote to Quad Link ⑥ with screw ④, Nord-Lock washer ⑤ and serrated lock washer ⑦.
  - ! Tighten screw ④ with a maximum torque of 25 Nm.

### Remote holder for attendant

The remote is fitted to the wheelchair using a bracket on the push handle or the push bar.



- 3 mm Allen key
- 5 mm Allen key
- 8 mm wrench

- 1.

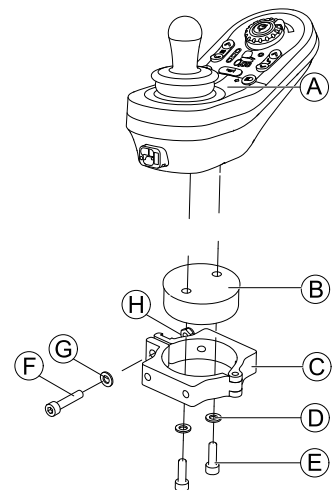

Mount remote ① with and support drum ② to clamp ③ with screws ⑤ and washers ④.

- 2.

**! Risk of damage to the remote**  
 The maximum torque to tighten the screw is 1 Nm.  
 – Do not exceed this rating as it may damage the remote.

Fix support drum ② in clamp ③ with screw ⑥, washer ⑦ and nut ⑧.

3.

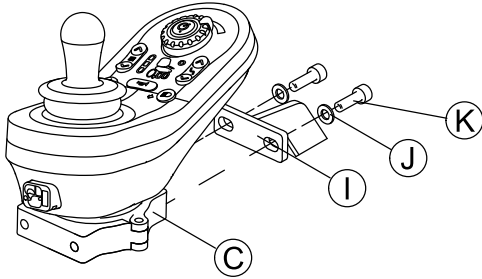

Attach clamp C to bracket I with screws K and washers J.

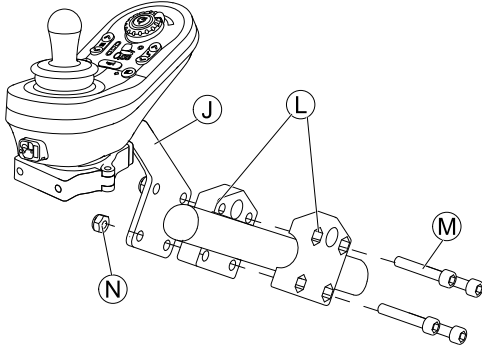

4.



Attach bracket I to gripper clamp L with screws M and nuts N.

### 3.9.3 Mounting the DLX-REM400

#### Standard remote holder

-  • 3 mm Allen key
-  • 8 mm wrench

1.

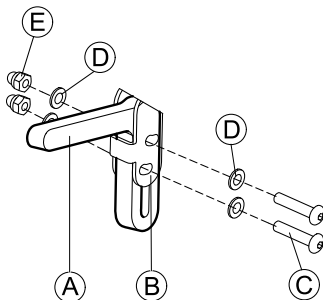



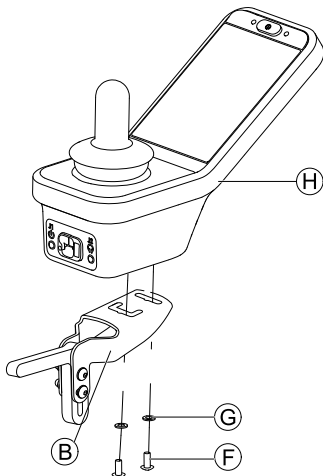

Mount joystick holder A to remote adapter B with screws C, washers D and nuts E.

2.



Mount remote H to remote adapter B with screws F and washers G.

#### Swing away remote holder

-  • 4 mm Allen key
-  • 3 mm Allen key
-  • 8 mm wrench
-  • 10 mm wrench

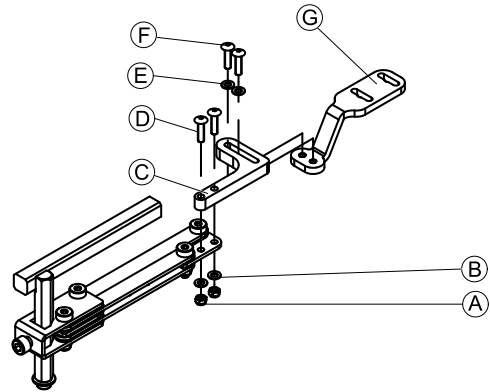

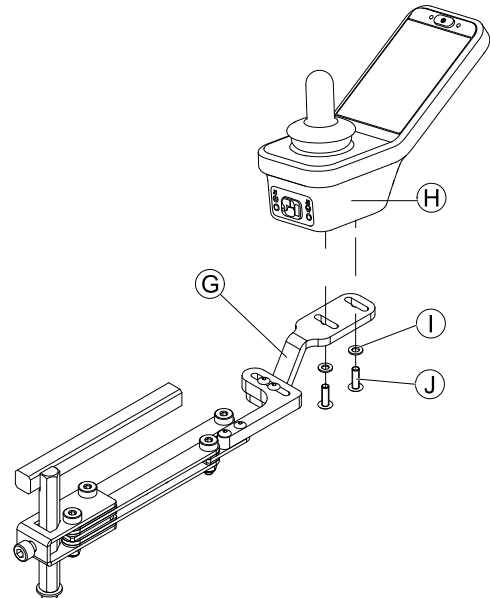

1. Pull screws D through bracket C, remote holder and washers B.
2. Tighten screws with nuts A.
3. Pull screws F through washers E, bracket C and bracket G and tighten screws.
- 4.



Tighten remote with screws A to bracket G.

#### Quad Link remote holder

-  • 3 mm Allen key
-  • 5 mm Allen key



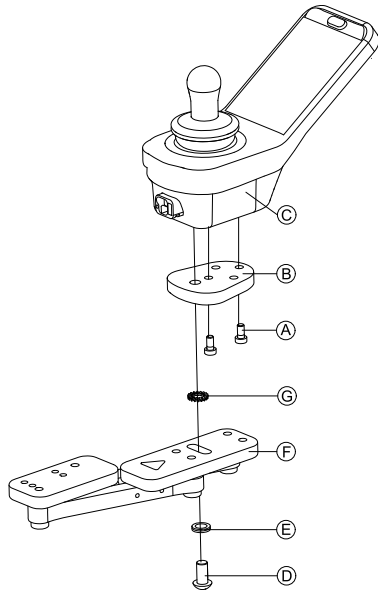

1. Mount LiNX remote adapter **B** with screws **A** to remote **C**.

**i** The LiNX remote adapter can be turned 90° right or left for more adjustment options.

2. Mount remote to Quad Link **F** with screw **D**, Nord-Lock washer **E** and serrated lock washer **G**.

**i** Tighten screw **D** with a maximum torque of 25 Nm.

#### Remote holder for attendant

The remote is fitted to the wheelchair using a bracket on the push handle or the push bar.

- |  |                  |
|--|------------------|
|  | • 3 mm Allen key |
|  | • 5 mm Allen key |
|  | • 8 mm wrench    |

1.

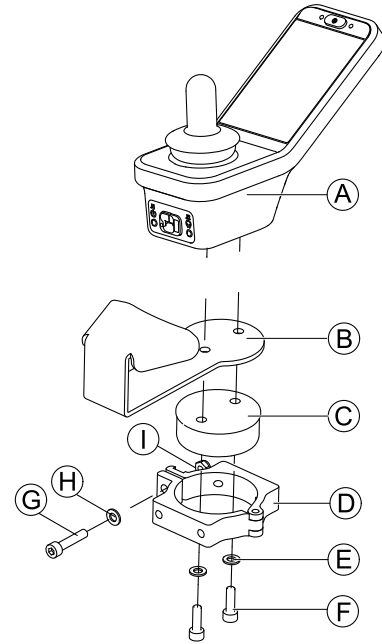

Mount remote **A** with support **B** and support drum **C** to clamp **D** with screws **F** and washers **E**.

2.

**!** **Risk of damage to the remote**  
 • The maximum torque to tighten the screw is 1 Nm.  
 – Do not exceed this rating as it may damage the remote.

Fix support drum **C** in clamp **D** with screw **G**, washer **H** and nut **I**.

3.

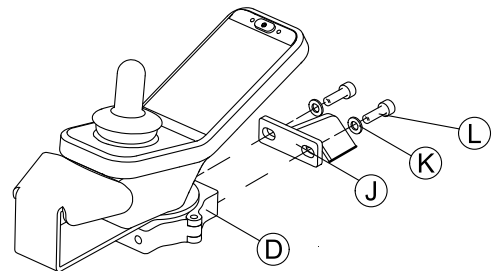

Attach clamp **D** to bracket **J** with screws **L** and washers **K**.

4.

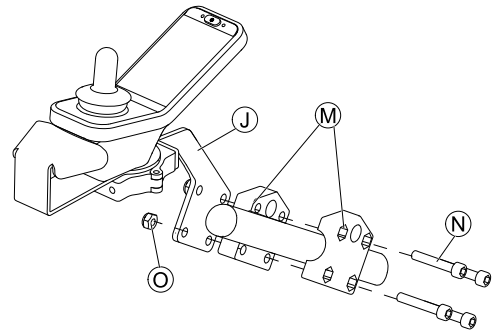

Attach bracket **J** to gripper clamp **M** with screws **N** and nuts **O**.

### 3.9.4 Mounting Toggle Switches on the DLX-REM400

**i** The toggle switches are suitable for the DLX-REM400-B remote module only — they must not be installed to the DLX-REM400-A version.



- TX8 Torx key
- Opening pick (or similar)
- Two additional screws (included in mounting kit)
- Label kit (included in mounting kit)

1.

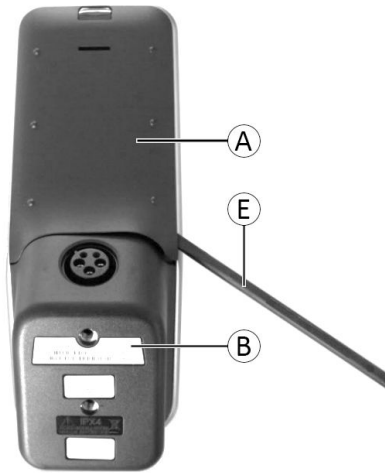

Fig. 3-10

Remove rear shroud (A) using opening pick (E).

2.

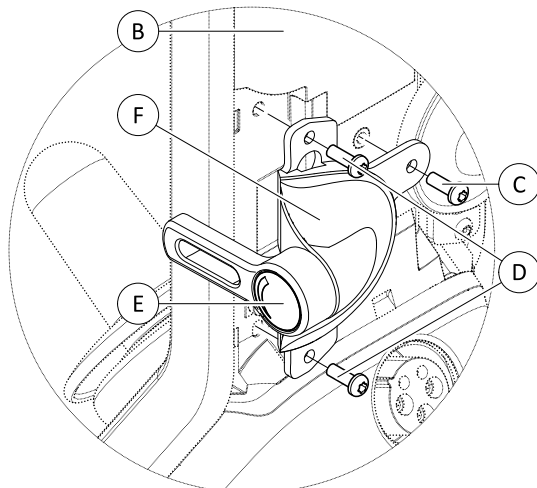

Fig. 3-11

Loosen and remove four silver screws (D).

3. Mount toggle switch (F) to remote (B) with screws (C) and (D).
4. Repeat step 2 and 3 to install second switch / blanking plate.
5. Install new rear shroud included in mounting kit.
6. Install labels (E) on both toggles.

### 3.9.5 Mounting the DLX-REM500

#### Swing away remote holder



- 3 mm Allen key
- 4 mm Allen key
- Medium-strength thread-locking fluid, e.g. Loctite 243

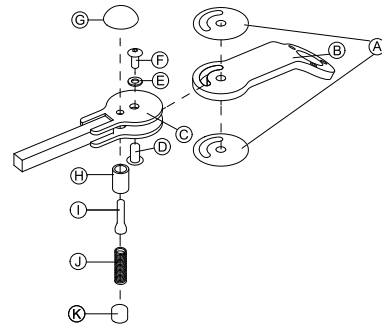

1. Connect slip sticker (A) with joint arm (B) and insert into support (C).
2. Fix with sleeve nut (D), washer (E) and screw (F).  
 ⓘ Apply medium-strength thread-locking fluid to screw (F).
3. Insert locking bolt (H) and compression spring (I) through support (C) and joint arm (B).
4. Fix with locking knob (G) and grub screw (J).  
 ⓘ Apply medium-strength thread-locking fluid to grub screw (J).

5.

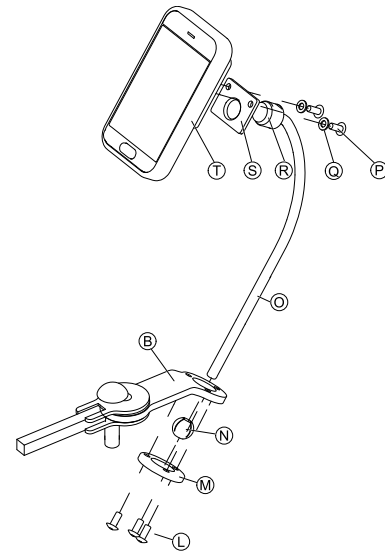

Insert bracket (O) into joint arm (B), clamp ball (N) and clamp ring (M).

Fix with screws (L).

6. Mount remote (T) to support plate (S) and clamping bush (R) with washers (Q) and screws (P).

#### Nucleus remote holder



#### CAUTION! Risk of Injury and Damage

Remaining burrs and missing end caps after modifications on rods, such as shortened rod, can lead to injury or damage.

- Deburr cut after cutting excessive length.
- Re-install end cap after deburring.



- 4 mm Allen key
- 3/16" Allen key

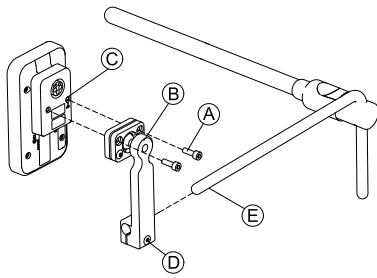

1. Mount remote © to bracket © with screws ©.
2. Pull bracket © over nucleus ©.
3. Tighten bracket to nucleus with screw ©.

### 3.10 Mounting the secondary remotes

 For more information about how remote holders are mounted to the wheelchair, refer to the service manual of the seating system.

#### 3.10.1 Mounting Intuitive Dual Control (IDC)

##### Mounting the KLICKfix adapter

###### Standard mounting

-  • Phillips screwdriver

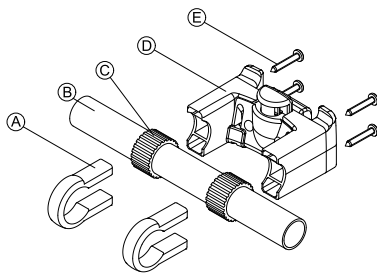

1. Position the tightening clamps © on the wheelchair push handle ©.
2. Make sure, the rubber band © is between the tightening clamps and the push handle.
3. Fit the KLICKfix adapter © onto the tightening clamps.
4. Tighten the screws ©.

###### Mounting on the Ultra Low Maxx seating system

-  • 4 mm (3/16") Allen key  
• Phillips screwdriver

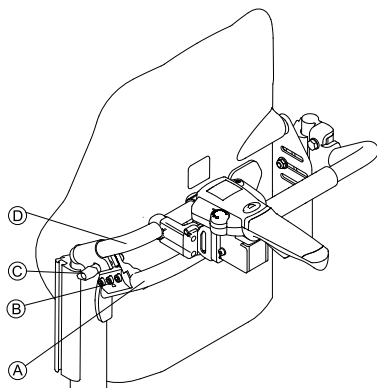

1. Fix the retaining clamp © on the wheelchair push handle ©.
2. Slide the adapter tube © through the retaining clamp.

3. Tighten the wing bolt ©.
4. Mount the KLICKfix adapter on the adapter tube, refer to chapter Standard mounting.

#### 3.10.2 Mounting the DLX-ACU200

##### Mounting for Modulite seating system

-  • 3 mm Allen key  
• 5 mm Allen key  
• 8 mm wrench  
• 10 mm wrench

1.

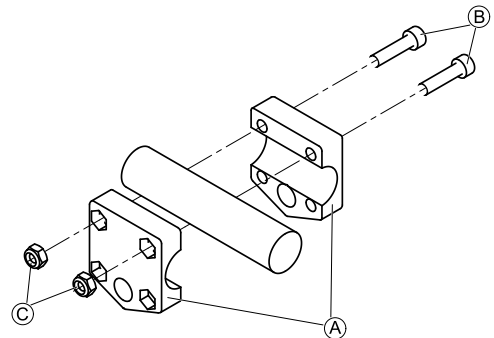

Attach gripper clamp © to tube with screws © and nuts ©.

2.

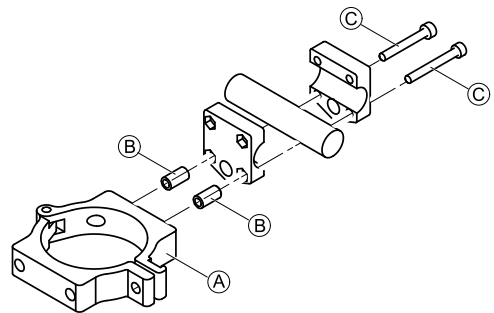

Attach clamp © and spacers © to gripper clamp with screws ©.

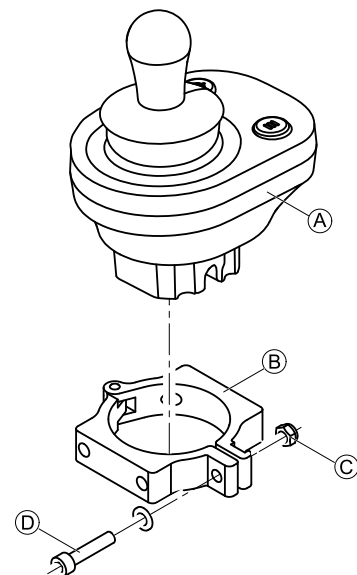

3.



**!** **Risk of damage to the remote**  
The maximum torque to tighten the screw is 1 Nm.  
– Do not exceed this rating as it may damage the remote.

Set remote © in clamp © and tighten screw © and nut ©.

### Mounting for Ultra Low Maxx seating system

-  • 3 mm Allen key
-  • 5 mm Allen key
-  • 8 mm wrench

1.

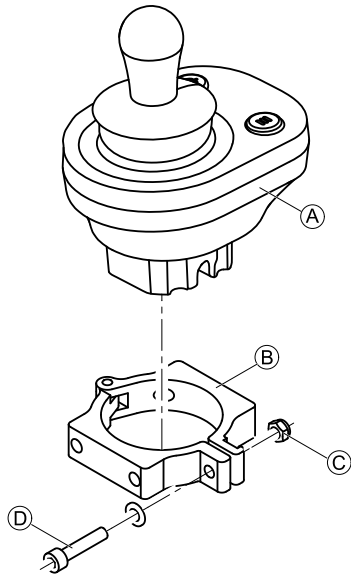

**!** **Risk of damage to the remote**  
 The maximum torque to tighten the screw is 1 Nm.  
 – Do not exceed this rating as it may damage the remote.

Set remote (A) in clamp (B) and tighten screw (D) and nut (C).

2.

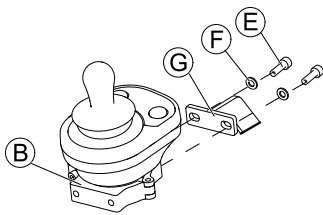

Attach clamp (B) to bracket (G) with screws (E) and washers (F).

3.

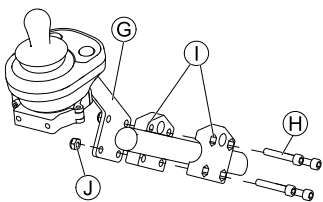



Attach bracket (G) to gripper clamp (I) with screws (H) and nuts (J).

### 3.10.3 Mounting the DLX-CR400

and DLX-CR400LF

#### Standard remote holder

-  • 3 mm Allen key
-  • 4 mm Allen key
-  • 8 mm wrench

1.

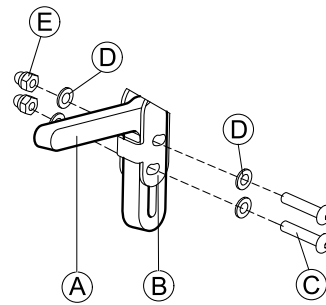

Mount joystick holder (A) to DLX-CR400 adapter (B) with screws (C), washers (D) and nuts (E).

2.

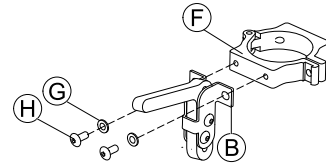

Attach clamp (F) to DLX-CR400 adapter (B) with washers (G) and screws (H).

3.

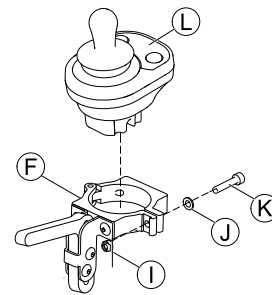

**!** **Risk of damage to the remote**  
 The maximum torque to tighten the screw is 1 Nm.  
 – Do not exceed this rating as it may damage the remote.

Set remote (L) in clamp (F) and tighten screw (K) and washer (J) with nut (I).

#### Nucleus remote holder



#### **CAUTION!** **Risk of Injury and Damage**

Remaining burrs and missing end caps after modifications on rods, such as shortened rod, can lead to injury or damage.  
 – Deburr cut after cutting excessive length.  
 – Re-install end cap after deburring.



- 4 mm Allen key
- 8 mm wrench

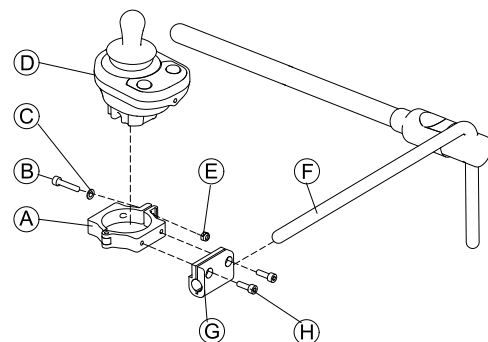



1.

**!** **Risk of damage to the remote**  
 The maximum torque to tighten the screw is 1 Nm.  
 – Do not exceed this rating as it may damage the remote.

Set remote ④ in clamp ① and tighten screw ② and washer ③ with nut ⑤.

2. Pull clamp bracket ⑥ over nucleus ⑦.
3. Attach clamp ① to clamp bracket ⑥ and fix everything with screws ⑧.

### 3.10.4 Mounting the DLX-REM050

-  • 4 mm Allen key
-  • 3 mm Allen key

The attendant control unit is fitted to the wheelchair using a bracket on the push handle or the push bar.

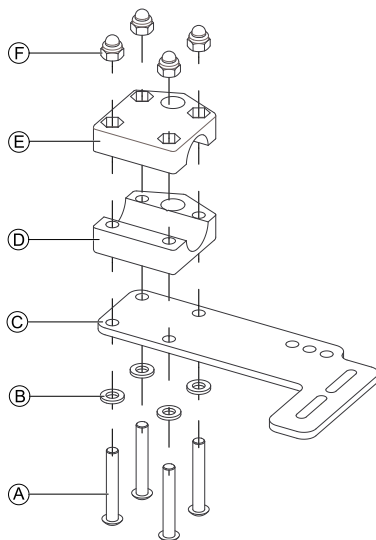

1. Pull screws ① through washers ②, mounting plate ③ and bottom side of bracket ④.
2. Tighten bottom side of the bracket to push bar with the top side of the bracket ⑤ and nuts ⑥.

3.

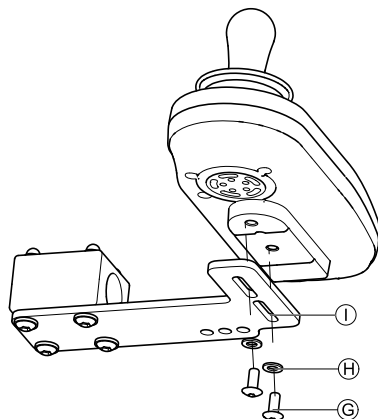

Pull screws ⑧ through washers ⑨ bracket ⑩ and attendant control unit.

4. Tighten screws.
5. Connect attendant control unit.

### Mounting positions

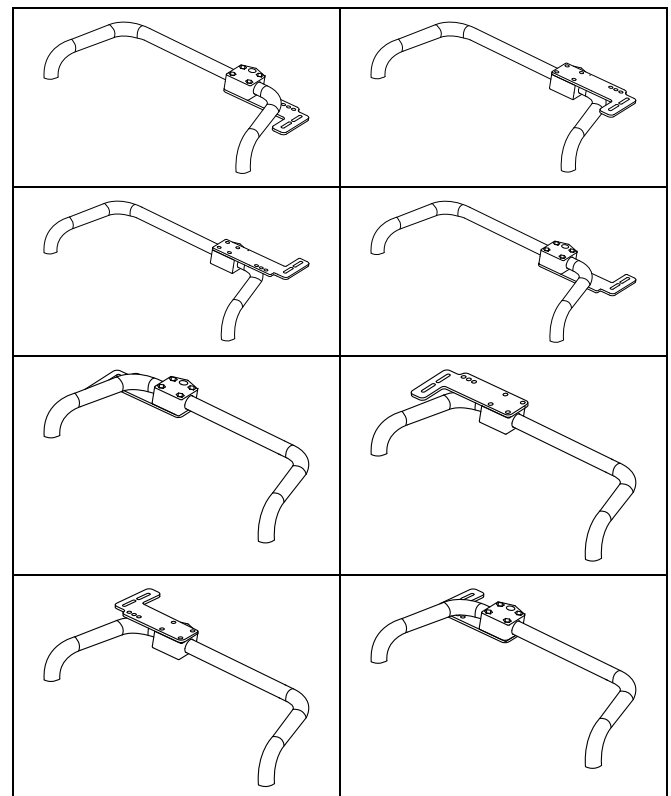

### 3.11 Mounting the ASL components

 For more information about how remote holders are mounted to the wheelchair, refer to the service manual of the seating system.

#### 3.11.1 Mounting Interface Boxes

##### Mounting ASL Joystick Interface Box for Ultra Low Maxx

-  • 5 mm Allen key

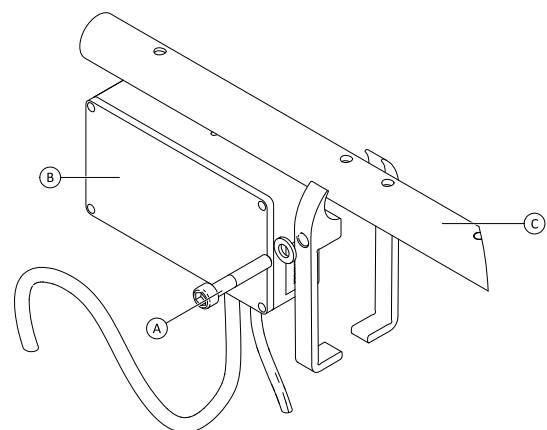





Fig. 3-12

1. Loosen screw ①.
2. Install Interface Box ②.
3. Place both parts onto armrest tube ③ and re-tighten screw ①.

##### Mounting ASL Joystick Interface Box for Modulite

-  • 3 mm Allen key
-  • 6 mm Allen key

 Illustration below shows left-hand mounted holder on seat with mounted flip-up armrest. Armrest holder **A** can be replaced by saddle washer and also mounting position can vary. Installation order is the same.

1.

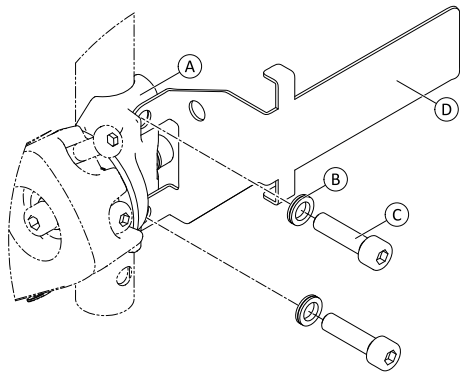

Fig. 3-13

Loosen and remove upper screw **C** and washer **B**.

2. Install base holder **D**. Ensure that armrest holder (saddle washer) **A** is installed in correct way and both holes are in line.
3. Re-insert screw and washer.
4. Repeat steps one to three for second screw.
5. Tighten both screws **C** to 6 Nm.
- 6.

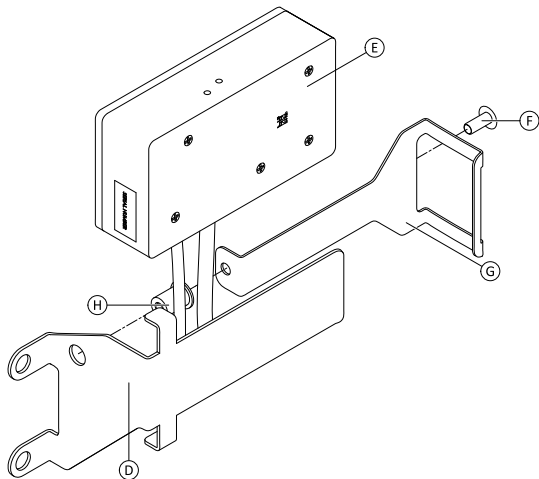



Fig. 3-14

Install well nut **H**, interface box **E** and holder **G**.

7. Tighten bolt **F** to 0.3 Nm.

### Mounting ASL106 Interface Box for Ultra Low Maxx (Manual Recline)

-  • 1/8 in Allen key  
• 3 mm Allen key  
• 8 mm wrench

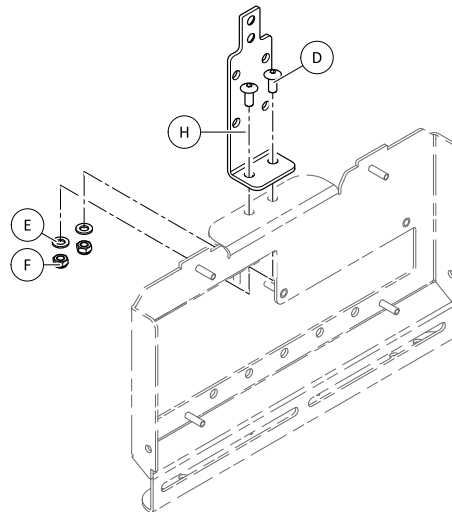

Fig. 3-15

1. Insert bolts **D**.
2. Install holder **H**, washers **E** and nuts **F**.
3. Tighten nuts **F**.
- 4.

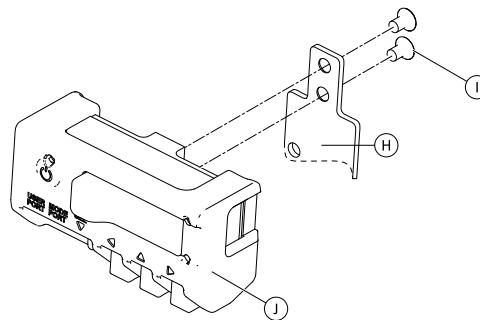



Fig. 3-16

Tighten interface box **J** to holder **H** with screws **I**.

### Mounting ASL106 Interface Box for Ultra Low Maxx (Powered Recline)

-  • 1/8 in Allen key  
• 5 mm Allen key  
• 6 mm Allen key  
• 13 mm wrench

1.

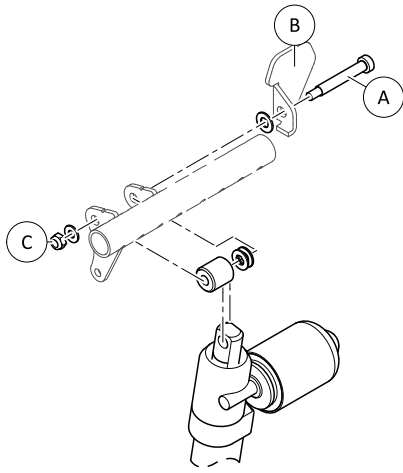

Fig. 3-17

Loosen and remove nut (C), washers, spacers and bolt (A).

2. Re-insert bolt (A) and flange (B), washers, spacers and nut (C).
3. Tighten nut.
- 4.

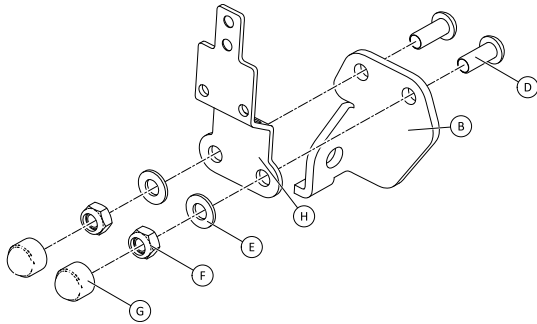

Fig. 3-18

Insert bolts (D).

5. Install holder (H), washers (E) and nuts (F).
6. Tighten nuts (F).
7. Install end caps (G).
- 8.

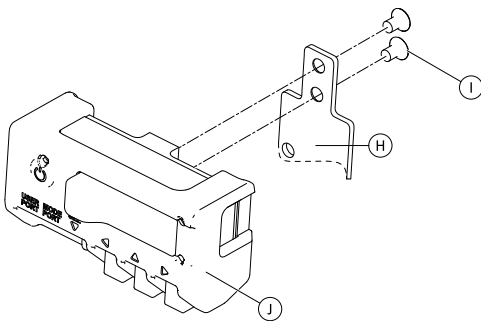

Fig. 3-19

Tighten interface box (J) to holder (H) with screws (I).

**Mounting ASL106 Interface Box for Modulite**

- 1/8 in Allen key
- 5 mm Allen key
- 13 mm wrench

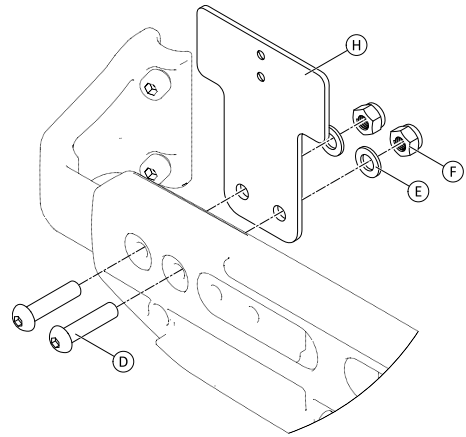

Fig. 3-20

1. Insert bolts (D).
2. Install holder (H), washers (E) and nuts (F).
3. Tighten nuts (F).
- 4.

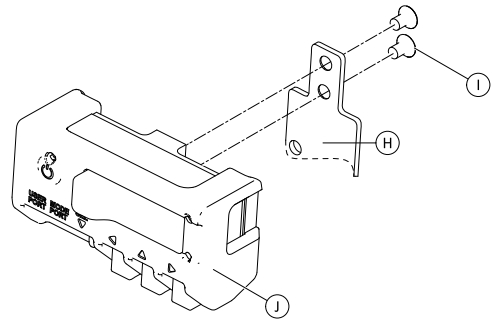

Fig. 3-21

Tighten interface box (J) to holder (H) with screws (I).

**Mounting ASL154 Sip And Puff Interface Box for Ultra Low Maxx**

- 5 mm Allen key
- Flat screwdriver

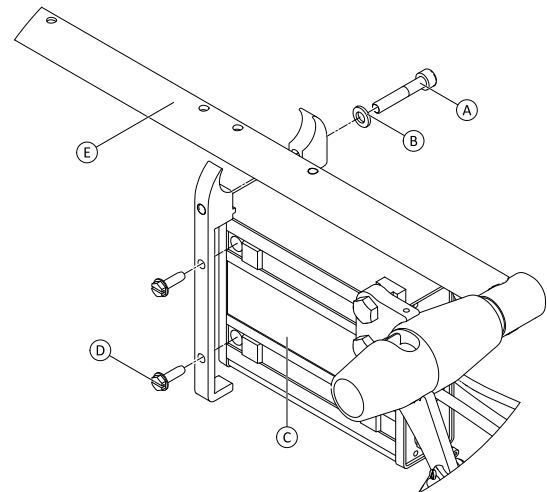





Fig. 3-22

1. Loosen screw (A).
2. Place holder on armrest tube (E) and re-tighten screw (A).
3. Install Interface Box (C) and tighten screws (D).

### 3.11.2 Mounting the Compact Single Switch Joystick

#### Lateral Tray Mount

-  • 1/8" Allen key
-  • 5/32" Allen key
-  • 3/16" Allen key

1.

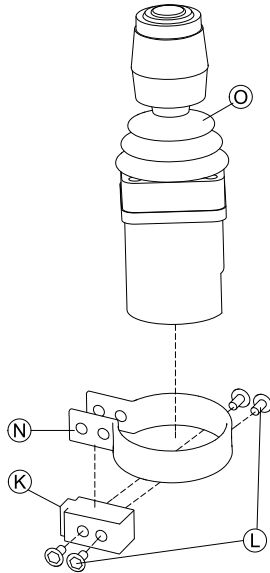

Fig. 3-23

Insert joystick **O** in clamp **N**, pull clamp over adapter block **K** and fix with screws **L**.

2.

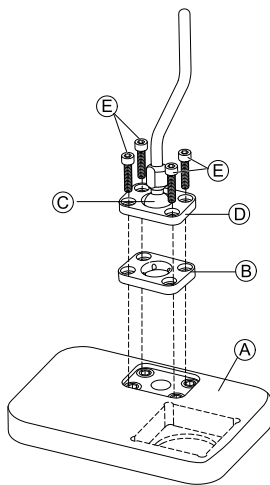

Fig. 3-24

Insert clamp plate **B** into cutout on tray **A**.

3. Fix clamp plate **B**, clamp ball **C** and upper clamp plate **D** with screws **E**.

4.

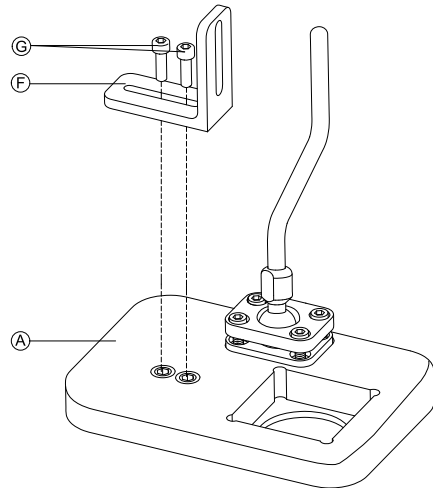

Fig. 3-25

Mount angle bracket **F** with screws **G** to tray **A**.

5.

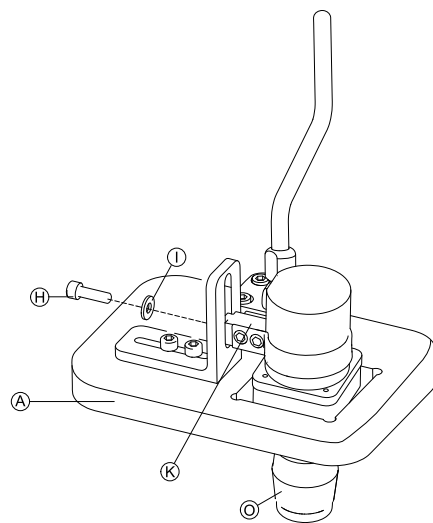

Fig. 3-26

Insert remote **O** into tray **A**.

6. Fix adapter block **K** to angle bracket **F** with screw **H** and washer **I**.

#### Nucleus Tray Mount



#### CAUTION!

#### Risk of Injury and Damage

Remaining burrs and missing end caps after modifications on rods, such as shortened rod, can lead to injury or damage.

- Deburr cut after cutting excessive length.
- Re-install end cap after deburring.



- 1/8" Allen key
- 5/32" Allen key
- 3/16" Allen key



1.

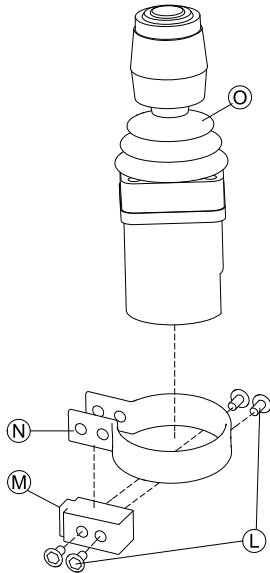

Fig. 3-27

Insert joystick © in clamp ①, pull clamp over adapter block ② and fix with screws ③.

2.

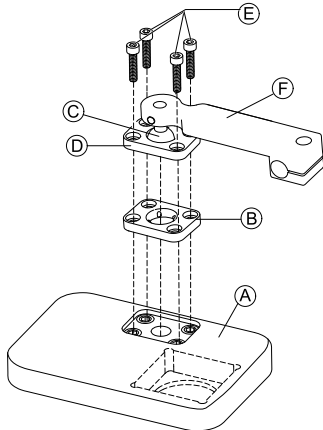

Fig. 3-28

Insert clamp plate ④ into cutout on tray ①.  
3. Fix clamp plate ④, clamp ball ⑤ and upper clamp plate ⑥ with screws ⑦.

4.

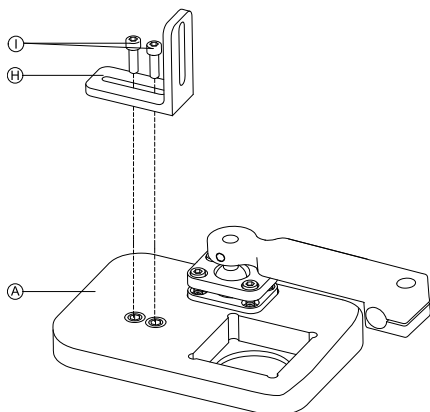

Fig. 3-29

Mount angle bracket ⑧ with screws ⑨ to tray ①.

5.

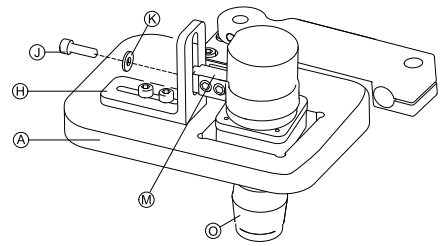

Fig. 3-30

Insert remote © into tray ①.

6. Fix adapter block ② to angle bracket ③ with screw ④ and washer ⑤.

7.

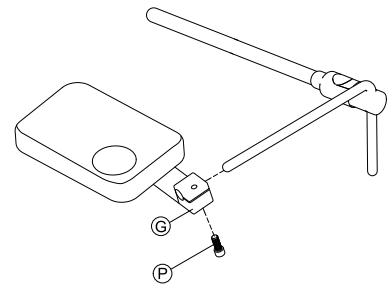

Fig. 3-31

Pull hitch mount ⑥ over nucleus and tighten with screw ⑦.

### Nucleus Only Mount



#### CAUTION!

#### Risk of Injury and Damage

Remaining burrs and missing end caps after modifications on rods, such as shortened rod, can lead to injury or damage.

- Deburr cut after cutting excessive length.
- Re-install end cap after deburring.



- 1/8" Allen key
- 5/32" Allen key

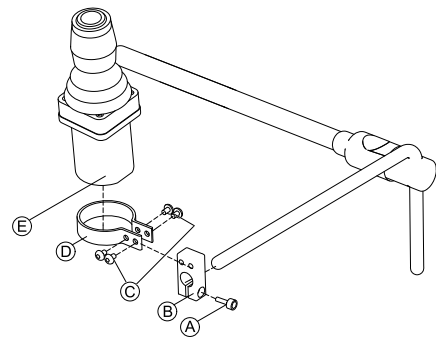

Fig. 3-32

1. Pull adapter block ② over nucleus and tighten with screw ①.
2. Insert remote ⑤ into clamp ④.
3. Mount clamp ④ to adapter block ② with screws ③.

### 3.1.1.3 Mounting the Micro Extremity Control Joystick

#### Lateral Tray Mount



- 1/8" Allen key
- 5/32" Allen key
- 3/16" Allen key

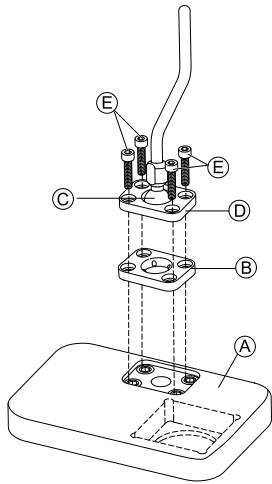

Fig. 3-33

1. Insert clamp plate B into cutout on tray A.
2. Fix clamp plate B, clamp ball C and upper clamp plate D with screws E.
- 3.

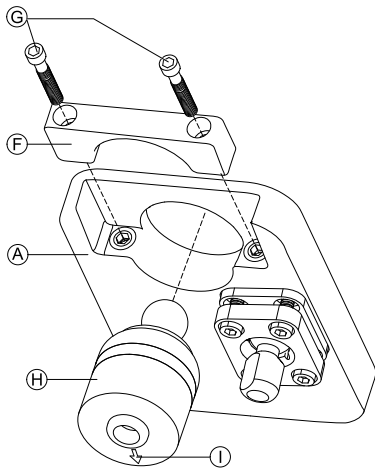

Fig. 3-34

Insert remote H from below into tray A. Make sure, arrow I shows into reverse driving direction.

**Nucleus Tray Mount**



**CAUTION! Risk of Injury and Damage**

Remaining burrs and missing end caps after modifications on rods, such as shortened rod, can lead to injury or damage.

- Deburr cut after cutting excessive length.
- Re-install end cap after deburring.



- 1/8" Allen key
- 5/32" Allen key
- 3/16" Allen key

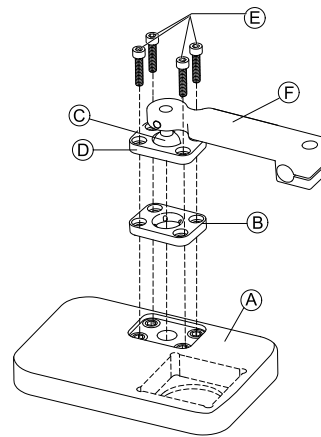

Fig. 3-35

1. Insert clamp plate B into cutout on tray A.
2. Fix clamp plate B, clamp ball C and upper clamp plate D with screws E.
- 3.

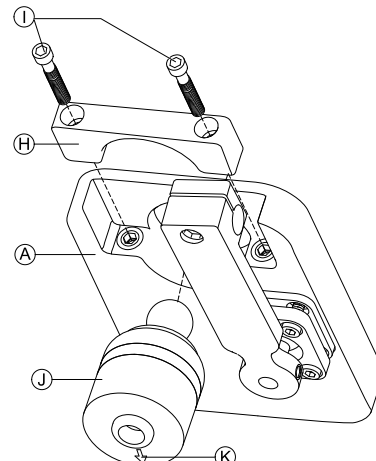

Fig. 3-36

Insert remote J from below into tray A. Make sure, arrow K shows into reverse driving direction.

- 4.

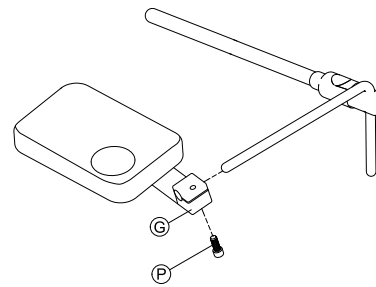

Fig. 3-37

Pull hitch mount G over nucleus and tighten with screw P.

**Nucleus Only Mount**



**CAUTION! Risk of Injury and Damage**

Remaining burrs and missing end caps after modifications on rods, such as shortened rod, can lead to injury or damage.

- Deburr cut after cutting excessive length.
- Re-install end cap after deburring.



- 1/8" Allen key
- 5/32" Allen key

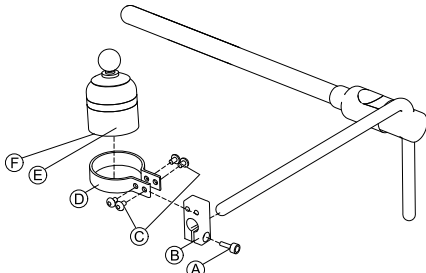

Fig. 3-38

1. Pull adapter block **B** over nucleus and tighten with screw **A**.
2. Insert remote **E** into clamp **D**. Make sure, arrow **F** (not visible in picture) shows into reverse driving direction.
3. Mount clamp **D** to adapter block **B** with screws **C**.

### 3.11.4 Mounting the Pediatric Compact Joystick

#### Lateral Tray Mount



- 1/8" Allen key
- 5/32" Allen key
- 3/16" Allen key

1.

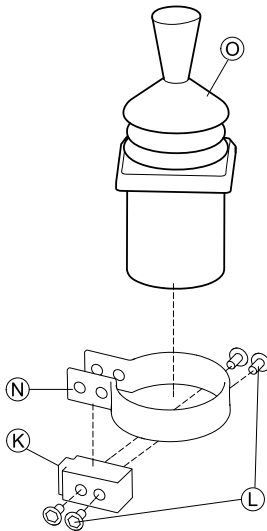

Fig. 3-39

Insert remote **O** into clamp **N**. Pull clamp over adapter block **K** and tighten with screws **L**.

2.

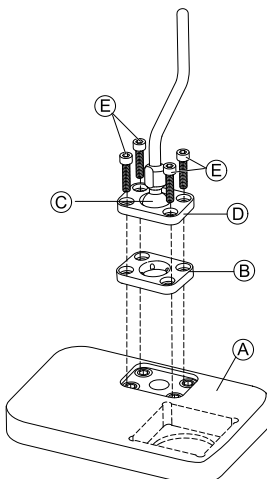

Fig. 3-40

Insert clamp plate **B** into cutout on tray **A**.

3. Fix clamp plate **B**, clamp ball **C** and upper clamp plate **D** with screws **E**.
- 4.

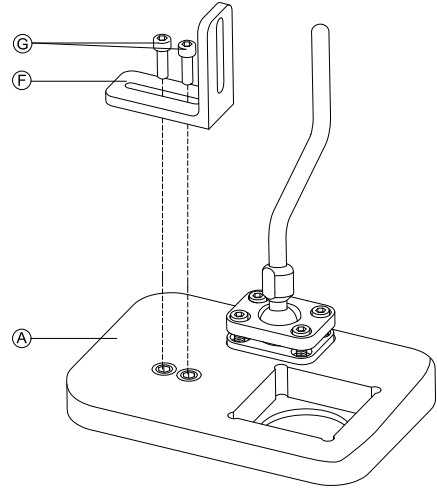

Fig. 3-41

Mount angle bracket **F** with screws **G** to tray **A**.

5.

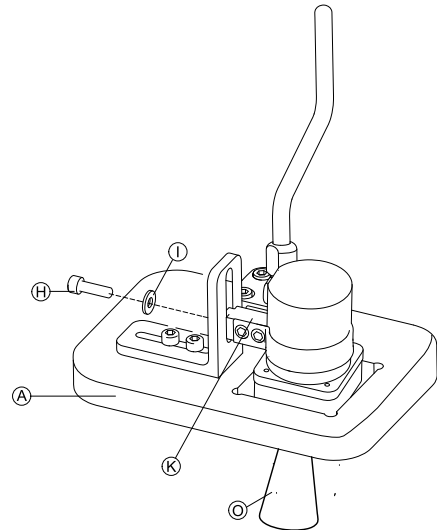

Fig. 3-42

Fix adapter block **K** to angle bracket **F** with screw **H** and washer **I**.

#### Nucleus Tray Mount



#### CAUTION! Risk of Injury and Damage

Remaining burrs and missing end caps after modifications on rods, such as shortened rod, can lead to injury or damage.

- Deburr cut after cutting excessive length.
- Re-install end cap after deburring.



- 1/8" Allen key
- 5/32" Allen key
- 3/16" Allen key

1.

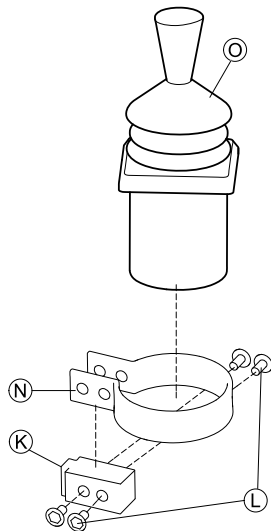

Fig. 3-43

Insert remote ① into clamp ②. Pull clamp over adapter block ③ and fix with screws ④.

2.

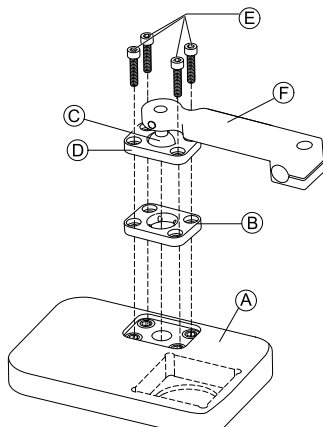

Fig. 3-44

Insert clamp plate ⑤ into cutout on tray ⑥. Fix clamp plate ⑤, clamp ball ⑦ and upper clamp plate ⑧ with screws ⑨.

4.

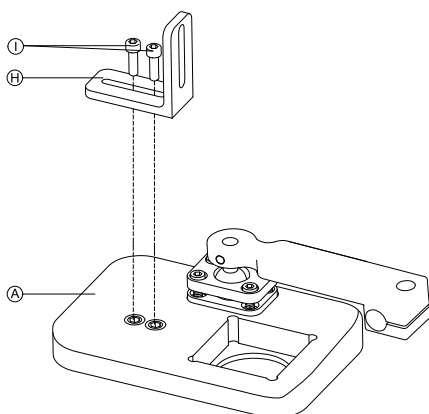

Fig. 3-45

Mount angle bracket ⑩ with screws ⑪ to tray ⑥.

5.

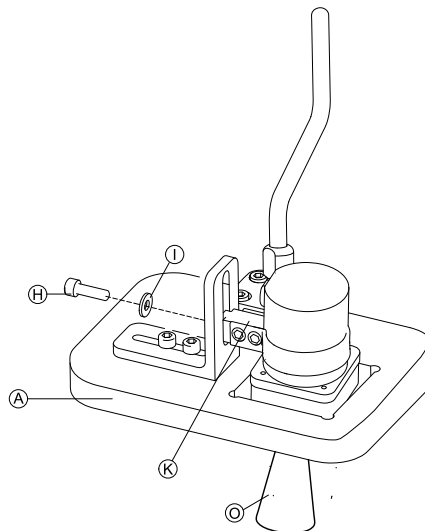

Fig. 3-46

Fix adapter block ⑬ to angle bracket ⑩ with screw ⑫ and washer ⑬.

6.

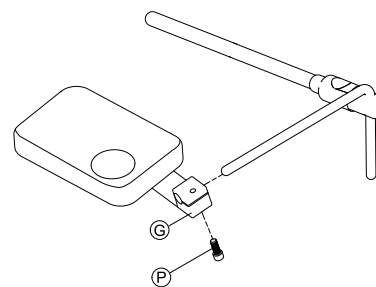

Fig. 3-47

Pull hitch mount ⑭ over nucleus and tighten with screw ⑰.

**Nucleus Only Mount**



**CAUTION!**  
**Risk of Injury and Damage**

Remaining burrs and missing end caps after modifications on rods, such as shortened rod, can lead to injury or damage.

- Deburr cut after cutting excessive length.
- Re-install end cap after deburring.



- 1/8" Allen key
- 5/32" Allen key

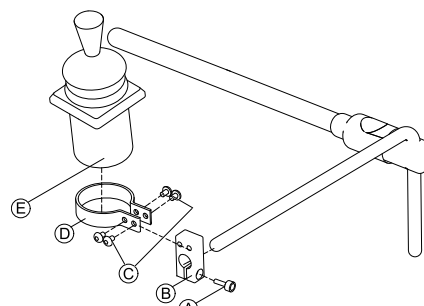

Fig. 3-48

1. Pull adapter block ② over nucleus and tighten with screw ①.
2. Insert remote ⑤ into clamp ④.
3. Mount clamp ④ to adapter block ② with screws ③.

### 3.11.5 Mounting the eclipse tray with proximity sensors



- 3/32" Allen key
- 5/32" Allen key
- 3/16" Allen key
- 4x loop straps 25x100 mm
- 4x hook straps 25x100 mm

1.

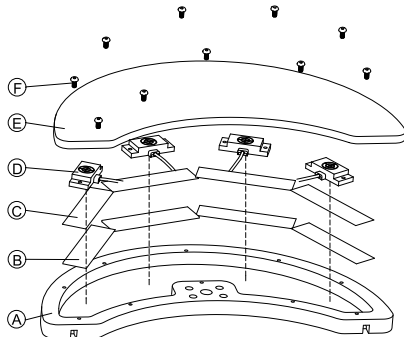

Fix hook straps B inside eclipse tray A.

2. Cut loop straps C accordingly shape of proximity sensors D.
3. Fix loop straps to proximity sensors.
4. Fix loop straps to hook straps.
- 5.



Pay attention that wiring of proximity sensors fit into intended gaps.

Fix coverage E to eclipse tray with screws F.

6.

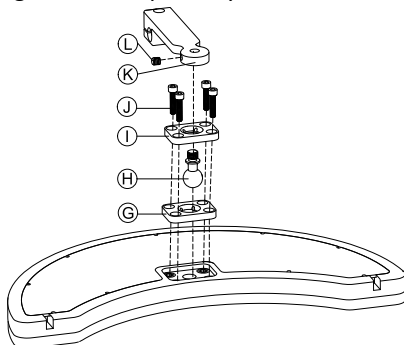

Insert clamp plate G into cutout on eclipse tray.

7. Fix clamp plate, clamp ball H and upper clamp plate I with screws J.
8. Screw hitch mount K to clamp ball with grub screw L.
- 9.

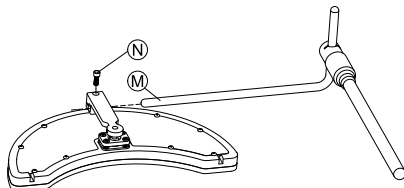

Pull hitch mount over nucleus M and tighten with screw N.

### 3.12 Mounting the 10 way switch



For more information about how 10 way switch holders are mounted to the wheelchair, refer to the service manual of the seating system.

While mounting the 10 way switch or changing the labeling, the orientation spot A must face downwards, see table below.

Orientation right	Orientation wrong

### 3.12.1 Mounting the 10 way switch for Modulte

#### Mounting at the front



- 3 mm Allen key
- 4 mm Allen key
- 8 mm wrench

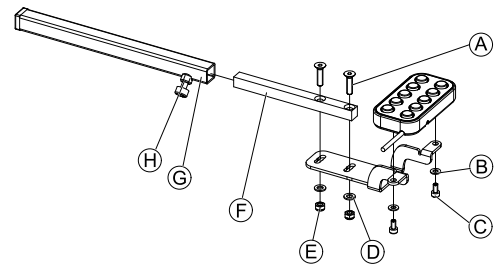

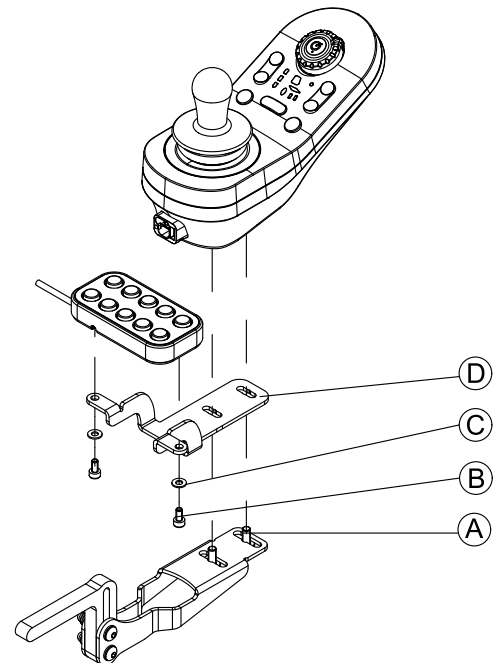

1. Tighten 10 way switch to bracket with screws C and washers B.
2. Tighten bracket to remote mounting tube F with screws A, washers D and nuts E.
3. Insert remote mounting tube inside mounting bracket G.
4. Adjust 10 way switch to desired position.
5. Tighten wing screw H.

#### In combination with DLX-REM211/DLX-REM216



1. Tighten 10 way switch to bracket D with screws B and washers C.
2. Tighten bracket to remote mounting bracket with screws A.

**Mounting at the rear (for attendants)**

-  • 3 mm Allen key
-  • 4 mm Allen key

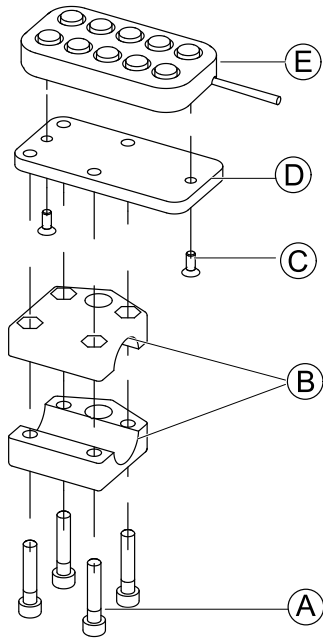

The 10 way switch is fitted to the rear of the wheelchair using a bracket B on the push handle or push bar.

1. Tighten mounting plate D with screws C to 10 way switch E.
2. Pull screws A through bracket B and mounting plate D.

**In combination with DLX-REM050 (attendant control unit)**

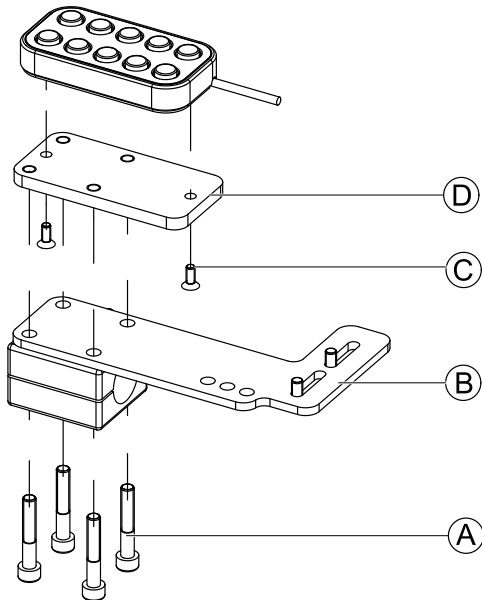



1. Tighten 10 way switch to mounting plate D with screws C.
2. Tighten mounting plate D to mounting plate B with screws A.

 For the possible positions of the attendant control unit, refer to 3.9.3 *Mounting the DLX-REM400*, page 32.

**3.12.2 Mounting the 10 way switch for Ultra Low Maxx**

**Mounting at the front**

-  • 3 mm Allen key
-  • 8 mm wrench

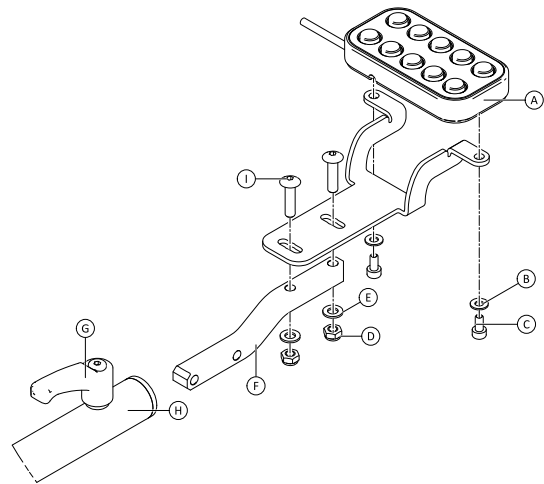



Fig. 3-49

1. Tighten 10 way switch A to bracket with screws C and washers B.
2. Tighten bracket to remote mounting tube F with bolts I, washers E and nuts D.
3. Insert remote mounting tube inside mounting bracket H.
4. Adjust 10 way switch to desired position.
5. Tighten lever G.

**In combination with DLX-REM2XX or DLX-REM400**

-  • 3 mm Allen key
-  • 8 mm wrench

1.

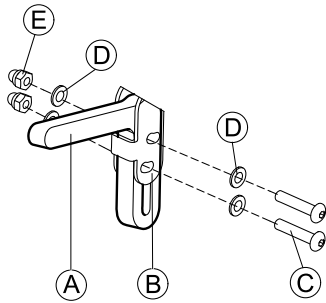

Mount joystick holder (A) to remote adapter (B) with screws (C), washers (D) and nuts (E).

2.

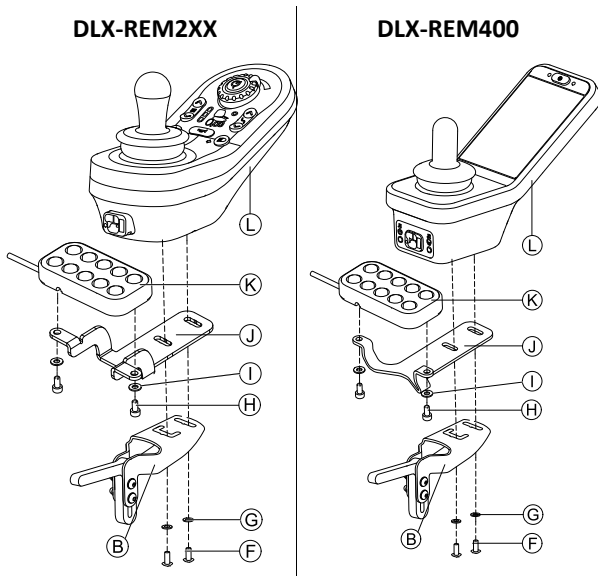

Mount remote (L) to remote adapter (B) and support sheet (J) with screws (F) and washers (G).

3. Mount 10 way switch (K) to support sheet (J) with screws (H) and washers (I).

For more information about mounting the 10 way switch for attendants, refer to the service manual of the Ultra Low Maxx.

### 3.12.3 Changing Labeling

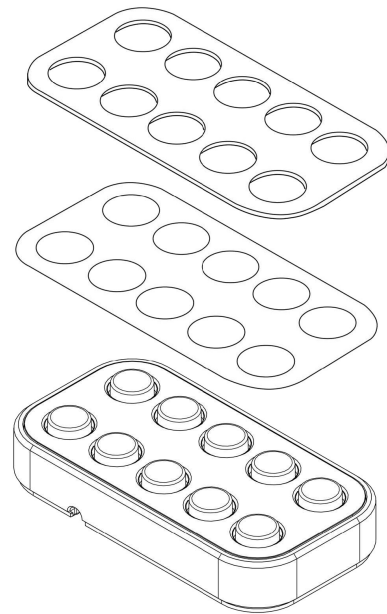



Fig. 3-50

-  • Small pointed tool (Nylon screw or similar)
-  • Label

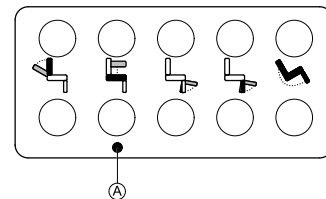



Fig. 3-51 Correct orientation of labeling

1. Remove switch from bracket.
- 2.



Fig. 3-52

Insert tool in upper two holes (B) on rear side and push out covering plate and labeling on other side.

3.  While installing new labeling, ensure that orientation spot (A) faces downwards and correct function icons are shown.

Replace labeling.

4. Install covering plate.
5. Install switch to bracket.

## 4 Replacing Wheelchair Components

### 4.1 General information on setup

The tasks described in this chapter are intended to be performed by trained and authorized service technicians for initial setup. They are not intended to be performed by the user.

### 4.2 Battery Synchronisation on New Batteries

The LiNX enhanced battery gauge integrates new technology that determines the State of Charge (SOC) of lead-acid batteries more accurately than conventional battery gauges which are based on battery-terminal voltage.

- The new enhanced gauge estimates the real SOC by looking at a number of factors, not just instantaneous terminal voltage, which on its own, is a poor indicator of SOC.
- The gauge does not measure current, which is difficult to do in a power wheelchair system.
- The gauge determines if the battery is charging or discharging, and depending on this state, applies logic and calculations to find the real SOC. Part of this is knowing the recent history of the battery use.
- The gauge models the discharge based on the terminal voltage, the rate of change of terminal voltage and how long the battery has been in this state, to get an actual SOC.
- The new gauge differentiates between real charging and regenerated voltage or recovery, which causes a distortion of the charge estimate in conventional gauges.
- If the battery is actually charging, the change in SOC is calculated based on where it is in the charge cycle, the rate of change in the terminal and how long it has been charging.

#### New Batteries

The enhanced battery gauge uses the recent charge / discharge history of the battery to calculate the SOC. When new batteries are connected, this history is no longer applicable, but the gauge will continue to calculate the SOC based on the information from previous battery. To rectify this, the enhanced battery gauge needs to be synchronised to the new batteries.

 Battery manufacturers recommend that batteries are formatted when new. This involves cycling the battery a number of times without deep discharging them. This procedure does not impact on the gauge synchronisation for new batteries.

#### Synchronizing new Batteries

1. Connect new batteries to power wheelchair.
2. Reset battery statistics using LiNX Access tools, see *Resetting battery usage, page 111*
3. Connect power wheelchair to battery charger. This must be done with system switched ON or within 24 hours of system being switched on.

4. Leave power wheelchair connected to battery charger for longer than ten minutes.
5. Wait until battery gauge displays more than 80 % (5 LEDs).
6. Leave power wheelchair connected to battery charger for at least two hours. For a new battery, the time should be an extended period as per battery manufacturer's recommendations.

### 4.3 Replacing Power Module as Spare Part

Replacing power module sets configuration and included parameters back to default settings. Up to eight pre-configured configurations for different wheelchairs were stored on power module until June 2018. For rules for file naming, see *12 Structure of Program Names, page 113*

 We recommend to take backups of current configuration, if possible. For more information on creating backups see *7.3.7 Saving programs, page 64* for iOS or *9.5.4 Save a program as a file, page 89* for PC.

1. If possible, take backup of current configuration.
2. Replace power module. For more information see corresponding service manual of wheelchair.
3. Connect wheelchair and LiNX Access tool.
4. Perform setup procedure. See *4.4 Setup Procedure After Power Module Replacement, page 48*.

### 4.4 Setup Procedure After Power Module Replacement

After replacing a power module we recommend that you perform following procedures to ensure that customized settings of your user won't be lost and the user gets access to the latest features of LiNX.

#### Upgrading Firmware / Write Bundle File

Upgrading the firmware of the LiNX components to the latest versions allow your user to use the newest features and other improvements Invacare introduced for the wheelchair. Currently there are two different ways to ensure that your system is up-to-date:

- Using Firmware Upgrade Mode (needs internet connection)
- Write Bundle File

Bundle files contain at least one wheelchair configuration and/or the latest firmware upgrades for the installed LiNX components.

1. Upgrade firmware to latest release.
  - a. **Firmware Upgrade Mode:** For iOS tool, see *7.3.8 Upgrading firmware, page 65*. For PC tool, see *9.5.6 Upgrading Firmware, page 89*.
  - b. **Bundle File:** For iOS tool, see *7.4.2 Writing Bundle Files, page 66*. For PC tool, see *9.6.3 Writing bundle files to a chair, page 92*.

#### Restoring Backup File

 We recommend to write a previously saved backup file to wheelchair after installing a new power module.



1. Restore backup file to wheelchair.  
For iOS tool, see 7.3.6 *Writing a program to the wheelchair, page 64*. For PC tool, see 9.5.2 *Write a program to a wheelchair, page 88*.
2. If needed, modify parameters to match user needs.

### Calibrating Adaptive Load Compensation (ALC)

During the ALC calibration process an utility calculates motor resistance values to help providing a more consistent motor speed. In case of installing a new power module the module must re-learn this values.

1. Perform suggested programming procedure. See 6.3 *Step 3 – Set load compensation, page 56*.

### Converting Old Configurations (Optional)

1. Convert configuration to enable latest feature, such as Switch Control.  
For iOS tool, see 7.3.4 *Converting Configuration Files, page 63*. For PC tool, see 9.5.9 *Converting Configuration Files, page 91*.

### Setting up Alternative Inputs (Optional)

For iOS tool, see 8.13 *Installing / Setting up alternative inputs, page 79*. For PC tool, see 10.13 *Installing / Setting up alternative inputs, page 106*

1. Set parameter **Profile User Input** or **User Function Input** on desired function or profile to **Input Module** or to **Third Party**, depending on component input.
2. Set parameter **User Input Configuration (Chair Setup → Modules → IN 5xx / TPI)** to desired input type.



Check if default value of parameter meets installed input type.

3. Modify other parameters, depending on used component.

### Setting up Alternative Outputs (Optional)

1. Set parameters for short and long press in utility card to desired values.  
For iOS tool, see 8.14 *Installing / Setting up Alternative Outputs, page 80*. For PC tool, see 10.14 *Installing / Setting up Alternative Outputs, page 106*

### Modifying Lighting Parameters (Optional)

1. Edit lighting parameters to desired values.  
For iOS tool, see 8.5 *Modifying Lighting Parameters, page 73*. For PC tool, see 10.3.1 *Modifying Lighting Parameters, page 94*.

### Modifying Gyro Support in Drive Functions (Optional)

1. Set parameter **Gyro Enabled Drive Function** to desired value.  
For iOS tool, see 8.6 *Modifying Gyro Support in Drive Functions, page 74*. For PC tool, see 10.3.2 *Modifying Gyro Support in Drive Functions, page 95*.

## 5 Overview LiNX Access tools

The LiNX system is programmed during manufacturing with default settings. These settings can be modified with a programming tool to suit the user.

The LiNX system can be programmed with one of two programming and diagnostic tools:

- LiNX Access iOS tool used with Apple’s iPhone, iPad and iPod touch with iOS 9.0 or later and
- LiNX Access PC tool used with Windows-based PCs or laptops with Windows 7 or later.

The programming and diagnostic tools communicate with a LiNX system via Bluetooth. The Bluetooth capability of a LiNX system is provided by a LiNX Access Key inserted into the remote module’s XLR socket.

If your PC does not have built-in Bluetooth, then a Bluetooth adaptor plugged into a spare USB port can be used instead.

Both, the iOS and the PC programming tools, offer a Live edit mode that allows certain parameters to be programmed, and take effect, while the system is live (e.g. while driving). For more information, refer to 7.3.5 *Modifying a Program, page 63*.

### 5.1 The LiNX Access Key

- ! – The LiNX Access Key is recommended for indoor use only, or outdoors in dry conditions.
- The LiNX Access Key must not be plugged in when in radio frequency (RF) sensitive environments.
- Always inspect the LiNX Access Key for damage before using it.
- Ensure that the LiNX Access Key is fully inserted into the XLR socket before use.
- Confirm that the connection is made to the wheelchair that is to be programmed by checking the LED on the LiNX Access Key.
- Take care while driving around during tuning of the wheelchair not to damage the LiNX Access Key by hitting a solid object. Always keep a clear distance from any objects that could damage the LiNX Access Key.
- The surface of the LiNX Access Key can get hot if left in direct sunlight for long periods.
- Do not leave the LiNX Access Key connected to the system when the wheelchair is powered down or when the wheelchair is to be stored for a long time, as the Access Key will continue to draw from the batteries when the system is off. If left in place, the expected storage life of the system will not be met and the batteries may be damaged.

The LiNX Access Key provides the Bluetooth connection for a programming tool to communicate with a LiNX system.

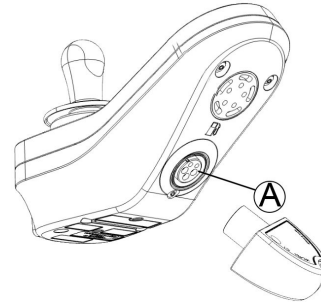

The LiNX Access Key plugs directly into the remote module’s XLR port (A). REM2xx displayed in picture, works for REM400 and REM500 the same way.

The LiNX Access Key has a blue status indicator to show when it is:

- powered up, but not connected (indicator flashes slowly),
- connecting (indicator flashes quickly) or
- connected (indicator permanently on).

If the blue status indicator turns completely off while trying to connect, or while connected, remove the LiNX Access Key from the remote module, wait for 5 seconds and the reinsert it into the remote module before trying to connect again.

Before the programming tools can be used for programming and diagnostics, you need to pair the devices, which is the process of connecting the devices via Bluetooth. The pairing process differs depending on the programming tool that is used.

#### 5.1.1 Rename LiNX Access Key (only possible with LiNX Access PC tool)

The LiNX Access Key is normally identified with the letters **LAK** followed by a series of characters, for example: **LAK-L12147605**. Although each name is unique, identifying one key from another may become difficult when you have more than one LiNX Access Key. As an option, you can change the names of the keys to more familiar names.

1. Right-click on LiNX Access Key in **Open a Connection** tab. You may have to close your connection if you are already in a connection context.

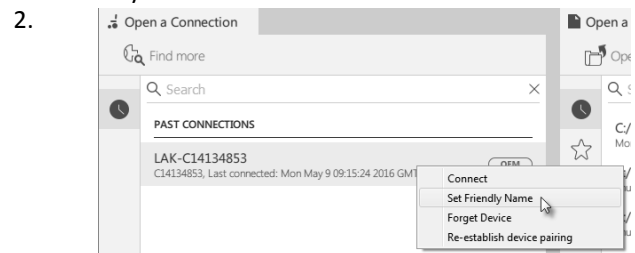

Select **Set Friendly Name** option from context menu.

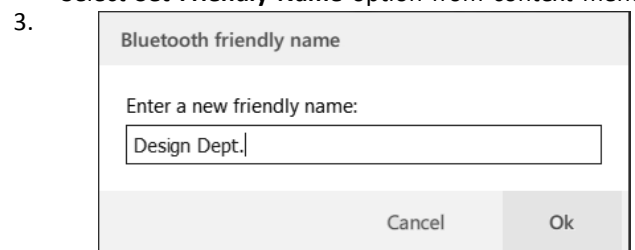

Enter new name into text box and click **OK** button.

After clicking **OK** button the wheelchair is power-cycled and the friendly name is updated. A confirmation screen

is displayed, informing you that the name was changed successfully.

## 5.2 Overview Functions

	Top level parameter categories	Parameter subcategories	
LiNX Access Tool (iOS or PC)	Chair Configs		
	Restore to Default Config		
	Diagnostics/Chair Log	For details see following table	
	Live Diagnostics <sup>1</sup>		Speed Demand
			Turn Demand
			Motor Voltage
			Motor Current
			Motor Resistance
			Battery Voltage
			Speed Dial
	System Summary	System modules with hardware number, firmware number and serial number	
	Functions	Different kind of functions and profiles	
	User Preferences		Drive Settings
			Switched Driving
			Sleep Settings
		Lock Settings	
		User Function Navigation	
		Control Input/Output Settings	
		Display Settings	
	Energy Use Settings		
Chair Setup	For details see following table		
Lighting		Turn indicators	
		Position	

Top level parameter	Parameter subcategories		
Diagnostics/Chair Log	Active Errors	Active error list	
	Chair Log/Event Log	Log	
	Chair Statistics		Battery usage
			Drive statistics

1. Live Diagnostics only available in Connection context mode

Top level parameter	Parameter subcategories		
Chair Setup	Modules	Power Module	Power Module <ul style="list-style-type: none"> <li>• Motors</li> <li>• Load Compensation</li> </ul>
			Control Inputs/Outputs 1–4
		Primary Remotes	Display Settings
			User Input
			Control Inputs/Outputs Jack Sockets
		Secondary Remotes	User Input
		TPI	User Input
			Control Inputs/Outputs 4–32
		Input Module	User Input
			Control Inputs/Outputs Jack Socket
	ACT200 <sup>2</sup>	Angle Sensor - Triggers	
		Control Inputs/Outputs 1–4	
	ACT400 <sup>2</sup>	Angle Sensor - Triggers	
		Control Inputs/Outputs 1–4	
Actuator Motions <sup>2</sup>	Seating Motion <sup>2</sup>	Identification	
		Behavior	
		Actuator Channels	

### 5.2.1 Overview User Preferences

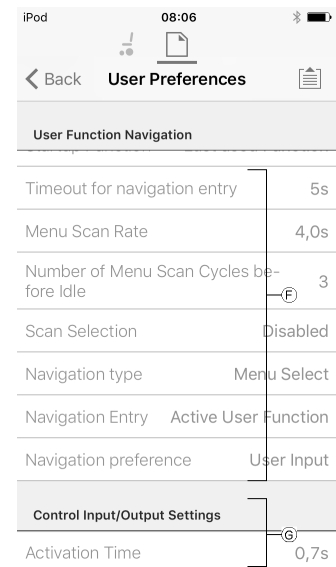
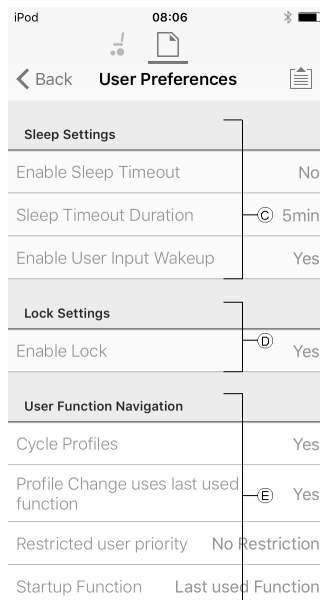
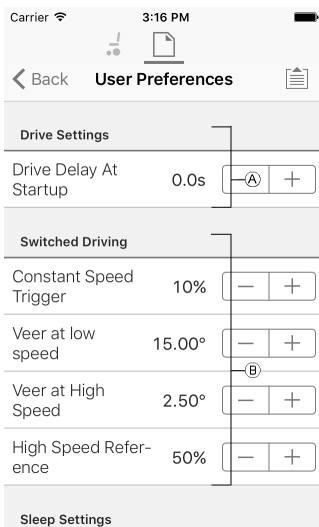

## 2. Optional

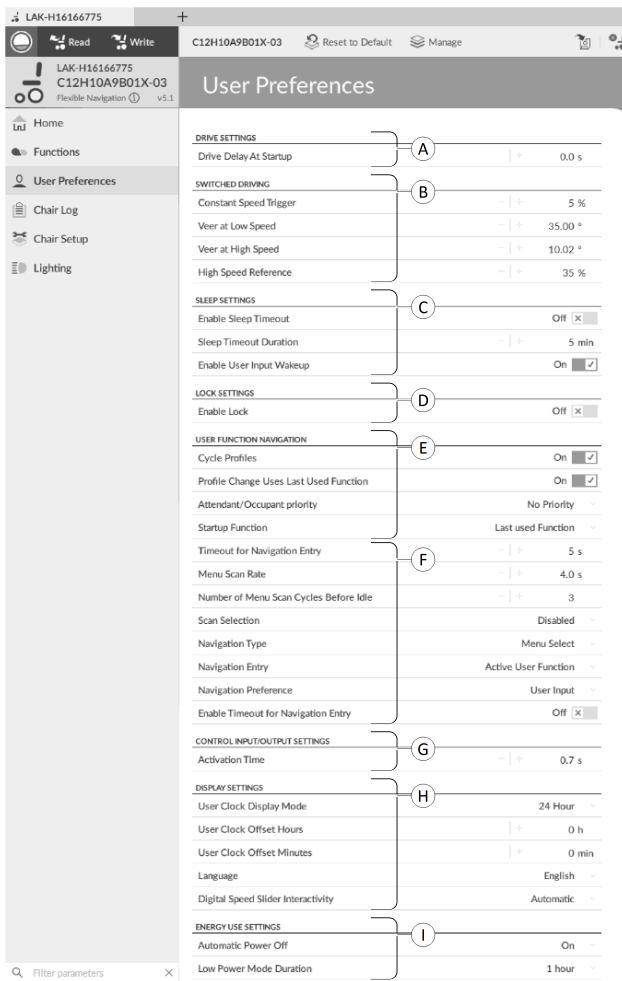

A	<b>Drive Settings</b>	<b>Drive Delay At Startup:</b> Allows time delay to be set up between power-up and driving.
B	<b>Switched Driving</b>	<p>These parameters set veer behavior of drive functions which use switched inputs, for example a Sip and Puff array. They are unique to switched driving and independent of forward, reverse and turn parameters that are used in driving and turning with proportional inputs, such as joysticks.</p> <p><b>Constant Speed Trigger:</b> Sets minimum forward / reverse speed during veer. If wheelchair is stationary or travelling at a low speed (lower than <b>Constant Speed Trigger</b>), speed ramps up to <b>Constant Speed Trigger</b>. Once at <b>Constant Speed Trigger</b>, speed remains constant.</p> <p><b>Veer at Low Speed:</b> Provides possibility of maximum veering at lowest speed. Value must be set greater than <b>Veer at High Speed</b>. Speed at which <b>Veer at Low Speed</b> is applied is set by <b>Constant Speed Trigger</b>.</p> <p><b>Veer at High Speed:</b> Is set to produce less veering at higher speeds. Value must be less than <b>Veer at Low Speed</b>. Speed at which <b>Veer at High Speed</b> is applied is set by <b>High Speed Reference</b>.</p> <p><b>High Speed Reference:</b> Sets point at which <b>Veer at High Speed</b> is applied. When wheelchair travels at speeds lower than this, veer is defined by graph between <b>Veer at Low Speed</b> and <b>Veer at High Speed</b>. For all speeds higher than <b>High Speed Reference</b>, amount of veer applied is the same as that set by <b>Veer at High Speed</b>.</p>
C	<b>Sleep Settings</b>	<p><b>Enable Sleep Timeout:</b> Determines whether system goes to sleep after a period without user activity.</p> <p><b>Sleep Timeout Duration:</b> Sets amount of time without user activity before system goes to sleep, if sleep is enabled.</p> <p><b>Enable User Input Wakeup:</b> Determines whether deflecting joystick can wake system from sleep.</p>

Ⓓ	<b>Lock Settings</b>	<b>Enable Lock:</b> Determines whether system can be locked by pressing power button for four seconds.
Ⓔ	<b>User Function Navigation</b>	<b>Cycle Profiles:</b> User profile menu either cycles or stops at each end. Parameter determines, if profile menu can cycle around when stepping through it.
		<b>Profile Change uses last used function:</b> Sets behavior of system to enter last used function of profile when particular profile is changed into.
		<b>Attendant/Occupant priority:</b> Selection for setting system user change restrictions. <sup>1</sup>
		<b>Startup Function:</b> Sets default user function on startup as either first user function of first profile or last used user function.
Ⓕ	<b>User Function Navigation</b>	See <i>10.10 Enable Indirect Navigation, page 101</i> for more information.
Ⓖ	<b>Control Input/Output Settings</b>	<b>Activation Time:</b> Sets maximum time between two button presses to be recognized as double press and minimum time to detect long button press. <sup>2</sup>
Ⓗ	<b>Display Settings</b>	<b>User Clock Display Mode:</b> Sets the display mode to the user clock to either 12 hour or 24 hour format.
		<b>User Clock Offset Hours:</b> Adjusts the display clock hour value to the time zone.
		<b>User Clock Offset Minutes:</b> Adjusts the display clock minutes value to the time zone.
		<b>Language:</b> Sets the language for text information on the display.
		<b>Digital Speed Slider Interactivity:</b> Sets whether the touch screen speed slider is able to be used in a system where it has the priority.
Ⓘ	<b>Energy Use Settings</b>	<b>Automatic Power Off:</b> Enables the LiNX system to power down itself after 12 hours of user inactivity. Parameter is equivalent to pressing a power button.
		<b>Low Power Mode Duration:</b> Sets the time which the LiNX system will remain in low power mode after power off. Low power mode is used to monitor battery charging, allow for joystick wakeup from sleep, and to apply electronic braking to actuators.

1 **Risk of injury or damage**

– When setting either occupant or attendant as restricted user in user-in-charge-system, consideration needs to be given to whether benefit outweighs risk, since restricted user is unable to take control from user by activating power button in emergency.



**CAUTION!**  
**Risk of injury or damage**

– When setting either occupant or attendant as restricted user in user-in-charge-system, consideration needs to be given to whether benefit outweighs risk, since restricted user is unable to take control from user by activating power button in emergency.

A restricted user is an occupant or attendant that is prevented from being user-in-charge once a system is powered up. By default, there are no restricted users in a LiNX system and both the attendant and the occupant can request to be user-in-charge at any time by pressing power button. However, for safety and other reasons, it may be appropriate to restrict the attendant or occupant from becoming user-in-charge after power-up. If restricted, any request to be user-in-charge is denied.

To restrict a user, set this parameter to:

- **No Priority:** Default
- **Occupant Priority:** to restrict attendant.
- **Attendant Priority:** to restrict occupant.
- **No Change Allowed:** to restrict attendant and occupant.

2 Parameter is used to distinguish between a single button press, a double-press and a long button press.

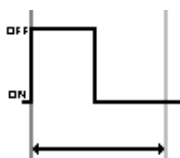

If duration time is less than **Activation Time**, input is detected as single press.

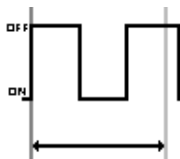

If duration of two button presses is greater than **Activation Time**, input is detected as two single presses.

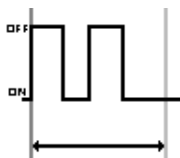

If duration of two button presses is less than **Activation Time**, input is detected as double-press.

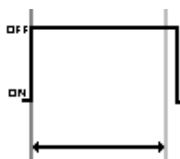

If duration of single button press is greater than **Activation Time**, input is detected as long press.

## 6 Suggested programming procedure



### CAUTION! Risk of injury or damage

- Perform following procedure in a large open environment, preferably outdoors. Make sure wheelchair cannot crash into other people or objects.
- Be prepared for unexpected wheelchair movement in event of a faulty installation.
- If wheelchair becomes uncontrollable, perform an emergency stop by turning LiNX system off.

The following outlines a suggested programming procedure for setting up the LiNX system. It is not prescriptive and should be used as a guideline only.

The following chapters show the preferred order in which to program the parameters, what effects the parameters have on the wheelchair and also how the various parameters interact with each other.

1. Power-up test
2. Check motor orientation
3. Set load compensation
4. Adjust speed settings
5. Adjust acceleration settings

The programming procedure is suitable for LiNX systems with or without a LiNX Gyro module fitted.

- For gyro-based systems, perform steps 1–3 without the gyro connected and then steps 4 and 5 with gyro connected.

### 6.1 Step 1 – Power-up test

Before programming, ensure that the system powers up successfully. Press and release the power button on the remote module. The status indicator should light green.

- If the battery cable or loom has not been correctly connected, the status indicator does not turn on.

If the status indicator flashes red, check the motors and park brakes as they may not have been connected properly. For more information about error codes, refer to the user manual of the remote.

### 6.2 Step 2 – Check motor orientation

Step 2 ensures that the motors are configured correctly.

1.

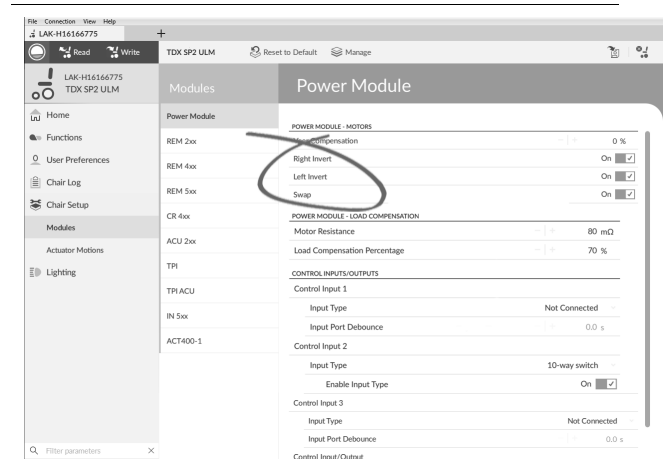
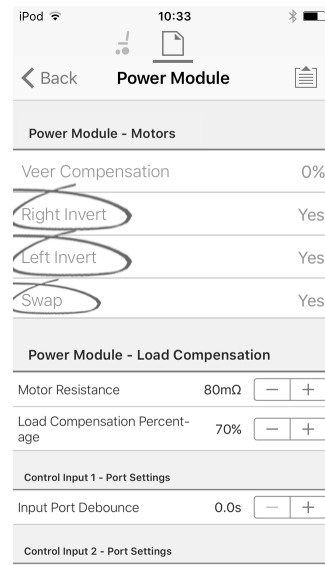

Open **Chair Setup** → **Modules** → **Power Module**.

#### Check for Motor Inversion

To detect motor inversion, deflect joystick slightly forwards.

- If wheelchair moves backwards instead of forwards, toggle both **Left Invert** and **Right Invert** parameters.
- If wheelchair turns on the spot, only one motor is inverted. To begin with, just toggle **Left Invert** parameter and deflect joystick forwards again. If wheelchair moves backwards, wheelchair now has both motors inverted. Toggle **Left Invert** and **Right Invert** parameters to fix this issue.

Before continuing, make sure that wheelchair moves correctly forwards and backwards.

#### Check for Motor Swap

To detect motor swap, deflect joystick to left. If wheelchair moves right, toggle **Swap** parameter.

Before continuing, make sure that wheelchair moves correctly forwards, backwards, left and right.

### 6.3 Step 3 – Set load compensation

Load compensation relies on accurate motor resistance values to work effectively. The motor resistance values can



be calculated manually, from observation, or automatically with Adaptive Load Compensation (ALC).

**i** Invacare recommends adding the motor resistance values automatically, using Adaptive Load Compensation. Adaptive Load Compensation is a process that learns the resistance value of each motor automatically, individually and with  $m\Omega$  accuracy. Because a separate and accurate resistance value is applied to each motor, the wheelchair's drive performance is significantly improved.

Adaptive Load Compensation is enabled by default, so the Motor Resistance parameter value is not used.

For more information about ALC Calibration application with iOS tool, refer to 6.3.1 *Calibrating Adaptive Load Compensation (iOS tool)*, page 57.

For more information about ALC Calibration application with PC tool, refer to 6.3.2 *Calibrating Adaptive Load Compensation (PC tool)*, page 58.

After learning the motor resistance values with ALC Calibration application, drive the wheelchair and observe its performance over various surfaces and at different speeds.

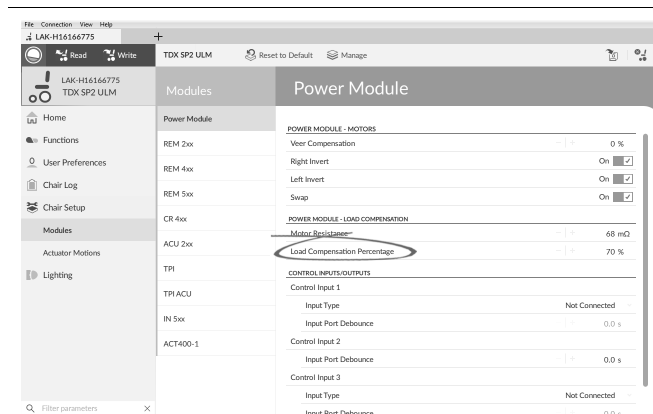
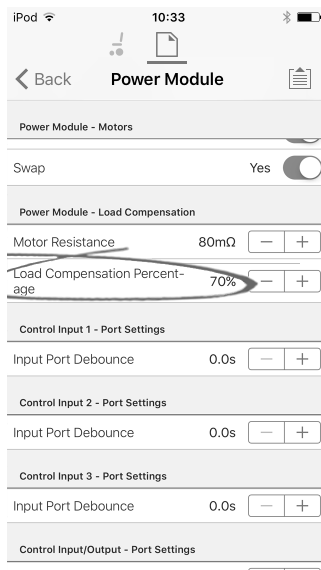

Open **Chair Setup** → **Modules** → **Power Module**.

If the wheelchair does not perform as desired, the effect of the adaptive load compensation can be adjusted using the **Load Compensation Percentage** parameter:

- reduce value of this parameter if wheelchair drives more aggressively than anticipated.
- increase value of this parameter if wheelchair drives more sluggish than anticipated.

**i** **Load Compensation Percentage** is only applied when **Adaptive Load Comp Enabled** is set to on.

### 6.3.1 Calibrating Adaptive Load Compensation (iOS tool)

**i** If the electronics or the motors have been changed, you need to calibrate the Adaptive Load Compensation (ALC).

1. From **Home** screen click on **Chair Setup**.
2. Click on **Power Module**.
3. Scroll down to **Power Module – Load Compensation** section.
- 4.

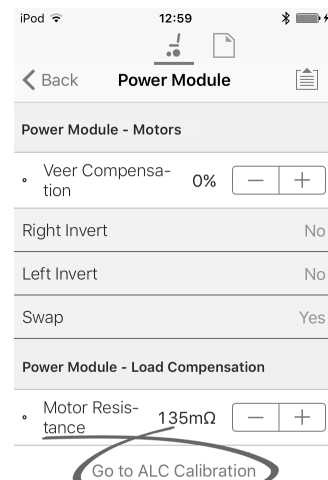

Click on **Go To ALC Calibration**.

- 5.

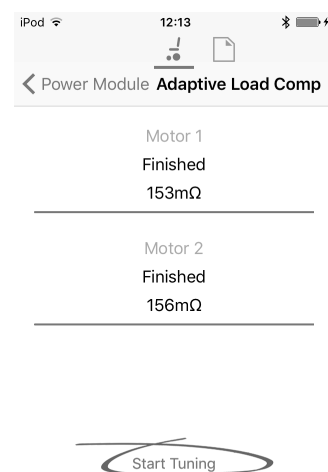

Drive the chair until both the left and right motor compensation processes have been completed.

Tap on **Start Tuning**.

6. Follow instructions on the screen.

### 6.3.2 Calibrating Adaptive Load Compensation (PC tool)

If the electronics or the motors have been changed, you need to calibrate the Adaptive Load Compensation (ALC).

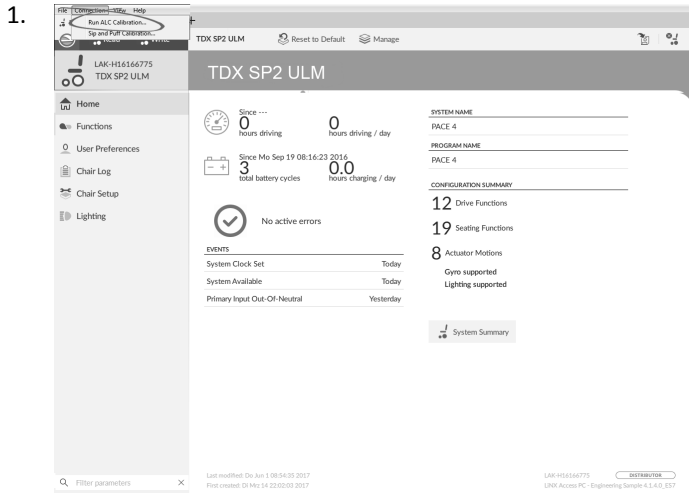

Click on **Connection** menu.  
Select **Run ALC Calibration**.

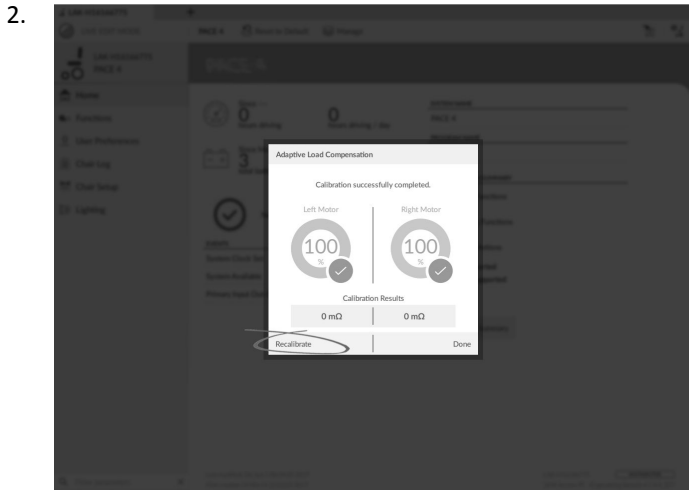

Click on **Recalibrate**.

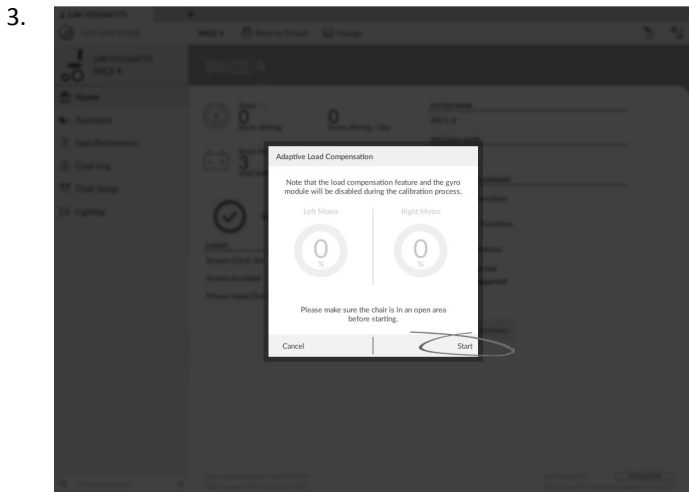

Click on **Start**.

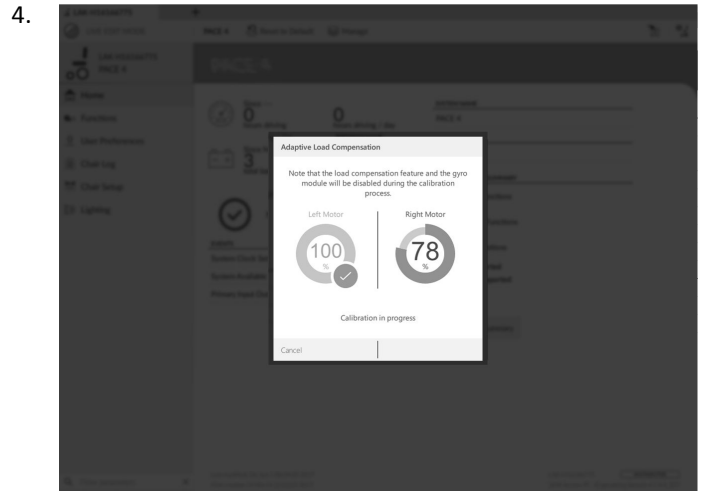

Drive chair until both left and right motor compensation processes have been completed.

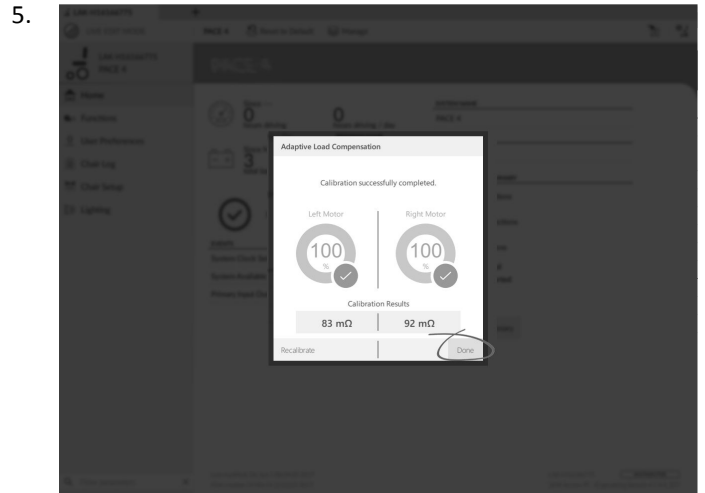

Click on **Done**.

### 6.4 Step 4 – Adjust Speed Settings

The following parameters must be set for each drive function.

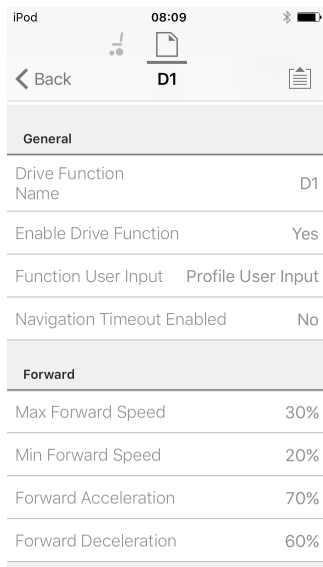

Fig. 6-1

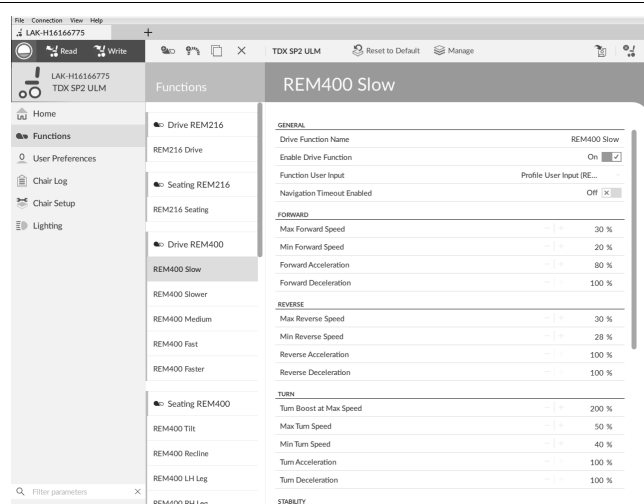

Fig. 6-2

1. Open **Functions** → open desired drive function.

### Adjust forward speed

Top speed of wheelchair can be reduced if desired. Set speed dial or slider to maximum and deflect joystick forward. Adjust **Max Forward Speed** parameter until forward speed seems like comfortable value.

### Adjust reverse speed

There is nothing physically preventing motors from driving at same speed in reverse as forward. Set speed dial or slider to maximum and deflect joystick in reverse. Adjust **Max Reverse Speed** parameter to set how fast wheelchair drives in reverse for comfortable and safe ride. Default is 50 % of maximum forward speed.

### Adjust minimum drive speeds

Set speed dial or slider to minimum and deflect joystick fully forward. Adjust **Min Forward speed** until desired minimum forward speed is reached.

Set speed dial or slider to minimum and deflect joystick fully in reverse. Adjust **Min Reverse speed** until desired minimum reversing speed is reached.

### Adjust turn speed

Set speed dial or slider to maximum and deflect joystick either left or right to turn wheelchair on spot. Wait until wheelchair reaches a steady turning speed. Adjust **Max Turn Speed** parameter until turn speed seems like a comfortable maximum.

Set speed dial or slider to minimum position to adjust **Min Turn Speed**.

### Adjust veer compensation

If wheelchair's motors do not perform exactly the same as each other, wheelchair does not drive in a straight line. To compensate differences between motors, adjust **Veer Compensation** parameter.

- 1.

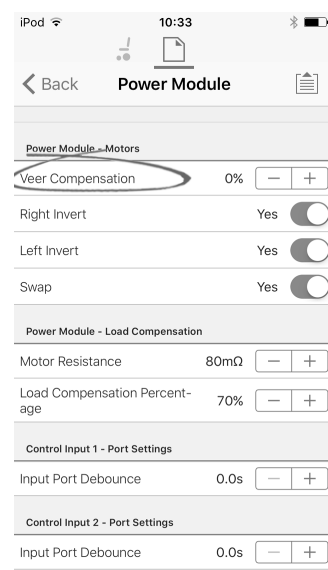

Fig. 6-3

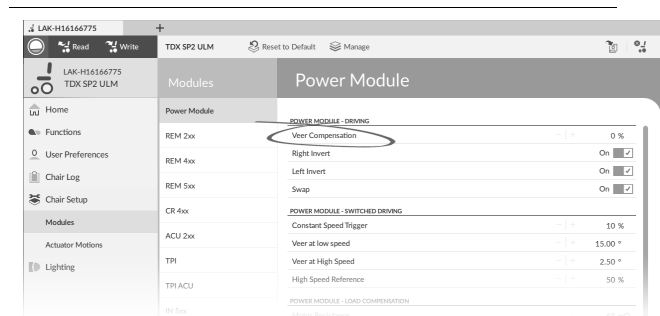
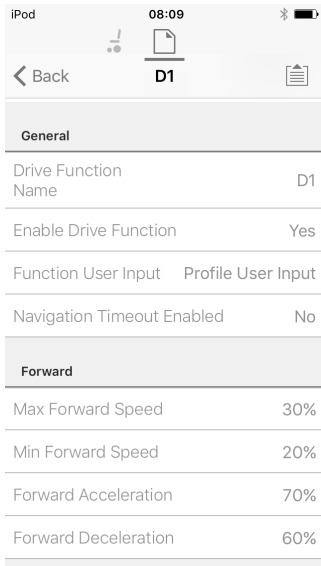

Fig. 6-4

Open **Chair Setup** → **Modules** → **Power Module**.

## 6.5 Step 5 – Adjust acceleration settings

The following parameters must be set for each drive function.



forwards speed. Adjust **Forward Acceleration** parameter if wheelchair gets up to steady speed too quickly or slowly. Repeat until acceleration feels comfortable and safe.

### Adjust forward deceleration

To set deceleration rate in forward direction, release joystick once wheelchair has reached steady forward speed. Adjust **Forward Deceleration** parameter if wheelchair slows down too quickly or slowly. Repeat until deceleration feels comfortable and safe.

### Adjust reverse acceleration

Set speed dial or slider to maximum and deflect joystick fully in reverse. Wait until wheelchair reaches steady reverse speed. Adjust **Reverse Acceleration** parameter if wheelchair gets up to steady speed too quickly or slowly. Repeat until acceleration feels comfortable and safe.

### Adjust reverse deceleration

To set deceleration rate in reverse direction, release joystick once wheelchair has reached steady reverse speed. Adjust **Reverse Deceleration** parameter if wheelchair slows down too quickly or slowly. Repeat until deceleration feels comfortable and safe.

### Adjust turn acceleration

Set speed dial or slider to maximum and deflect joystick either left or right to turn wheelchair on spot. Wait until wheelchair reaches steady turning speed. Adjust **Turn Acceleration** parameter if wheelchair gets up to steady turning speed too quickly or slowly. Repeat until acceleration feels comfortable and safe.

### Adjust turn deceleration

To set deceleration rate when turning, release joystick once wheelchair has reached steady turning speed. Adjust **Turn Deceleration** parameter if wheelchair slows down too quickly or slowly. Repeat until deceleration feels comfortable and safe.

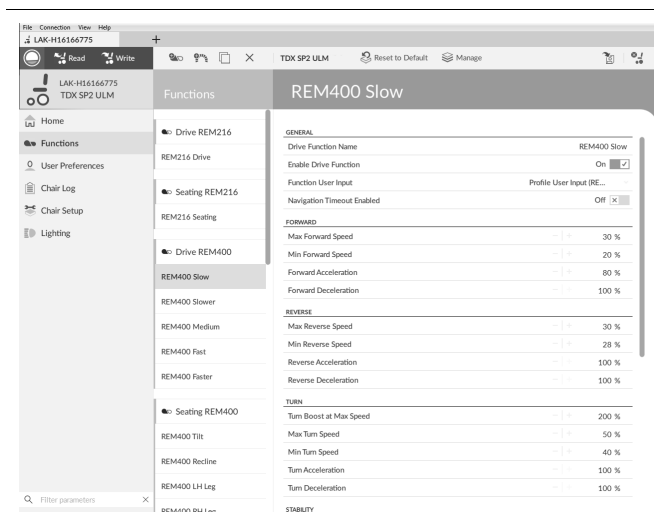

1. Open **Functions** → open desired drive function.

### Adjust forward acceleration

Set speed dial or slider to maximum and deflect joystick fully forward. Wait until wheelchair reaches steady

## 7 Using the LiNX Access iOS tool

### 7.1 Navigation bar

The navigation bar is located at the top of each screen. The content of the navigation bar changes depending on the screen you are viewing.



- Ⓐ Context switch (switch between connection and file context mode)
- Ⓑ Application menu button (edit button)
- Ⓒ Program name / screen name
- Ⓓ Close / navigate to previous screen

#### 7.1.1 Application menu

The content of the application menu changes depending in which context mode you are working with: **Connection context** or **File context**.

##### Connection context

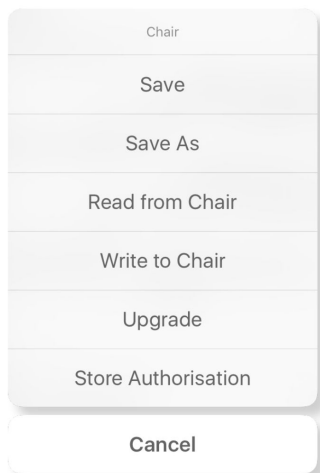

To work on a connected wheelchair, select **Connection context**. If you are not connected to a LiNX system the **Connect to device** screen is displayed. Otherwise, the last screen that you were working with, is displayed.

The following options are available in connection context:

- **Save** – save the configuration as a LiNX configuration file (.lci)
- **Save As** – save the configuration as a LiNX configuration file (.lci) with a different name
- **Read from Chair** – read the configuration from the connected LiNX system
- **Write to Chair** – write the configuration to the connected LiNX system
- **Upgrade** – go to firmware upgrade mode
- **Store authorization** – store an Access Level Certificate

##### File context

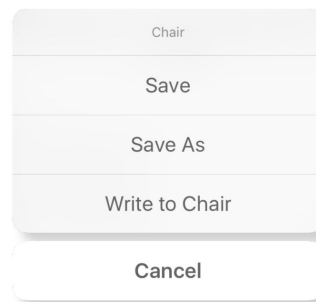

To work on a saved file, select **File context**. If you do not have a file open, the **Load from file** screen is displayed. Otherwise, the last screen that you were working on is displayed.

The following options are available in file context:

- **Save** – save the configuration as a LiNX configuration file (.lci)
- **Save As** – save the configuration as a LiNX configuration file (.lci) with a different name
- **Write to Chair** – write the configuration to the connected LiNX system

##### Selecting context mode



Click on the context switch at any time to toggle between **Connection context** and **File context**. The selected context displays a colored bar beneath the context switch icon.

#### 7.1.2 Changing Program Name

- ℹ By default, the program name and system name are composed of the wheelchair configuration. See *12 Structure of Program Names, page 113*

The program name can be changed to a more familiar name.



Fig. 7-1 Example of a standard program name. Marked areas and callouts correspond to the rules for program naming.

The program name in the picture was generated using the rules for program naming valid up to July 2018. It is for a Center Wheel drive TDX SP2 with a DLX-PM120AL, 8 km/h, seat lifter with powered tilt and CoG shift, REM1XX or REM2XX remote and LED light. The revision of the file is 00.



The new program name is saved depending on the mode you are working in.

- If you are working in **Connection context** and **Live edit** mode, changes are automatically written to the wheelchair.
- If you are working in **Connection context** and **Bulk edit** mode, click on **Write** button to save changes.
- If you are working in **File context**, click on **Save** button to save changes.

**iOS Tool**



Fig. 7-2

1. Click on **Program Name** in the navigation bar – a keyboard is displayed.
2. Edit program name.
3. Click **Return**.

**PC Tool**

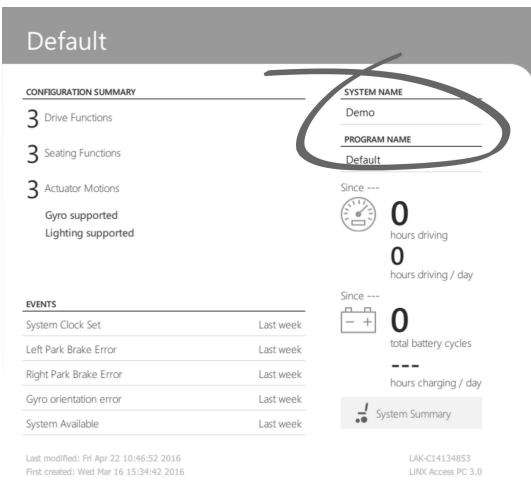
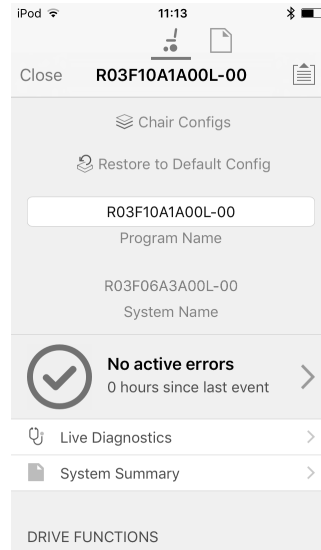

Fig. 7-3

1. From **Home** screen click on **Program Name** text box.
2. Edit program name.

**7.2 Home screen**



The **Home** screen is the first screen you see after connecting to a wheelchair or opening a configuration file. From the **Home** screen you can access the following programming and information screens:

- Chair configurations
- Active errors / Chair Log
- Live diagnostics (only in Connection context mode)
- System Summary
- Drive functions
- Seating functions
- User preferences
- Chair setup

**7.3 Connection context actions**



The following tasks are only relevant for the **Connection context** mode. For tasks related to the **File context** mode, refer to 7.4 *File context actions*, page 66.

**7.3.1 Connect to device screen**

The **Connect to device** screen is displayed when you are in **Connection context** before connecting to a LiNX system. From this screen you can search for and connect to a LiNX Access Key (LAK).

**Connecting the LiNX Access iOS tool with a wheelchair**

1. Power up LiNX wheelchair system.
2. Insert LiNX Access Key into the remote module.
3. Open LiNX Access iOS application.
4. Select **Connection context** mode.

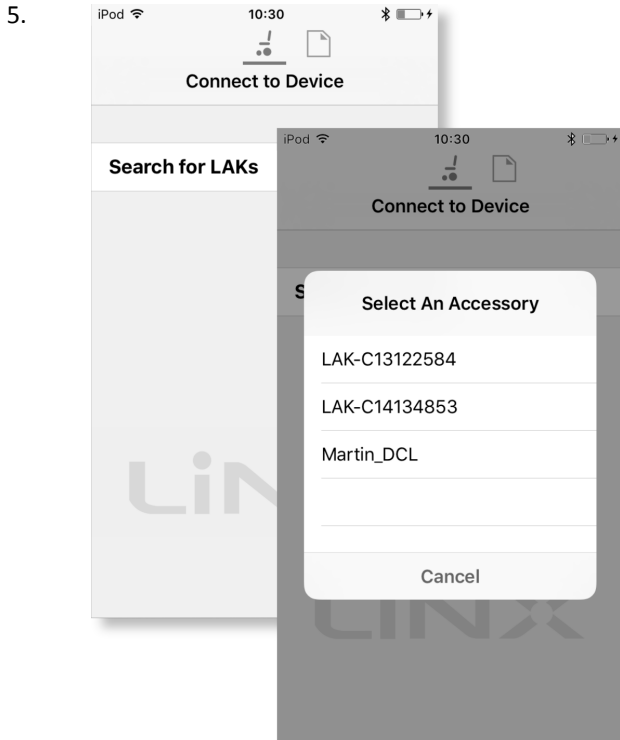

Click on **Search for LAKs** and select one from dialogue box **Select an Accessory**.

6. A **Warning** screen is displayed. Read the warning and click on **I Agree** button to continue.

#### Disconnecting

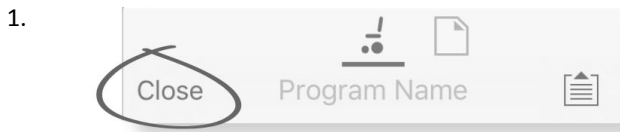

Click on **Close** button.

### 7.3.2 Reading a program from the wheelchair

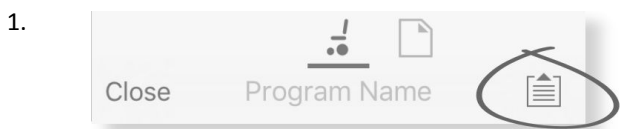

Click on **Application menu** button.

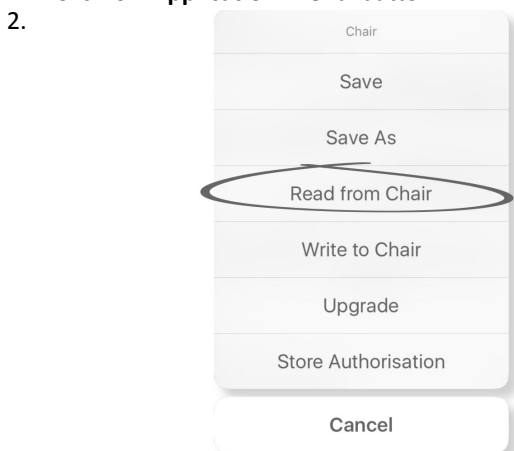

Select **Read from Chair**.

### 7.3.3 Restoring Default Wheelchair Configurations

The factory set-up for the power module provides one wheelchair configuration. If you order a power module as a spare part, it is provided with up to eight wheelchair configurations. Select the one you need.

1. Click on **Chair Configs** at the top of **Home** Screen. **Chair config** screen is displayed.
2. Click on named wheelchair configuration. A **Warning** screen is displayed.
3. Click on **Yes** to proceed with the selection.
4. Click on **Back** to return to **Home** screen.

When a new wheelchair configuration is selected, the system automatically power cycles before the wheelchair configuration becomes active.

### 7.3.4 Converting Configuration Files

Using older configuration files on wheelchairs can result in missing features which were introduced in later revisions of firmware, such as Switch Control. In most cases, converting these configuration files allows you to update user's configuration to latest release to enable all features.

In case configuration file is on current revision or incompatible, menu entry is shown greyed out.

1. Connect with wheelchair.
2. Open Application menu.
- 3.



Fig. 7-4

Tap on entry **Convert Configuration** and follow screen prompts.

### 7.3.5 Modifying a Program



To modify a program, first select a parameter from one of the parameter sections listed on the **Home** screen:

- Drive functions
- Seating functions
- User preferences
- Chair setup

Parameters can be modified numerically or graphically, refer to *10 Modifying wheelchair configuration with PC tool*, page 93.

Parameters can be modified in live edit mode or in bulk edit mode.

### Live Edit Mode

-  When in live edit mode, changes to parameters will take immediate effect, changing the performance of the wheelchair immediately.
-  There is no function to undo a change in live edit mode, so make sure, you save a copy of the existing program so that you can restore settings if you need to.

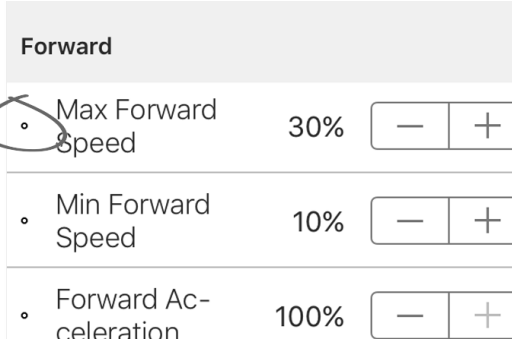

Fig. 7-5

Certain parameters can be updated in live edit mode. These are identified by a circular icon in front of the parameter name.

Live edit mode allows certain parameters to be written to the controller immediately. This is useful for speeding up the process of setting up or testing various applications and scenarios.

### Bulk Edit Mode

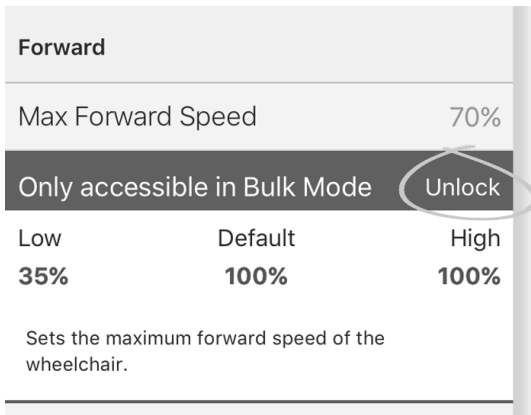



Fig. 7-6

Certain parameters can only be edited in bulk edit mode. These are identified by a colored background. To edit these parameters, bulk edit mode must be unlocked before proceeding.

In bulk edit mode, parameters are not written to the controller immediately. They are written to the controller, when you select **Write to Chair**, refer to 7.3.6 *Writing a program to the wheelchair*, page 64.

By default, live edit mode is enabled every time the system is powered up, including after a power cycle. The application remains in live edit mode until bulk edit mode is unlocked. At this point the application changes to bulk edit mode while live edit mode is disabled. The application remains in bulk edit mode until the system is power-cycled.

### 7.3.6 Writing a program to the wheelchair

-  This feature is only available when a wheelchair is connected.

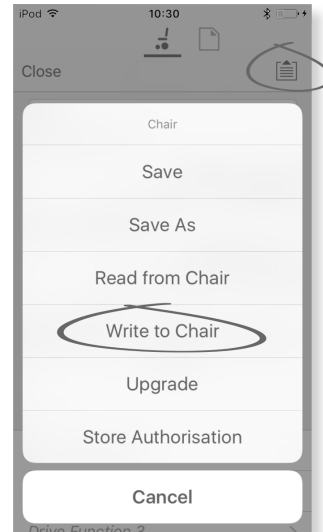

1. Click on **Application menu** button.
2. Select **Write to Chair**.

After writing to the wheelchair, the LiNX Access tool cycles the system's power and automatically reconnects to the system.

-  The **Application menu** dialogue in this picture shows all available options, when you are in **Connection context**. In **File context** the selection is more limited.

### 7.3.7 Saving programs

#### Using Save

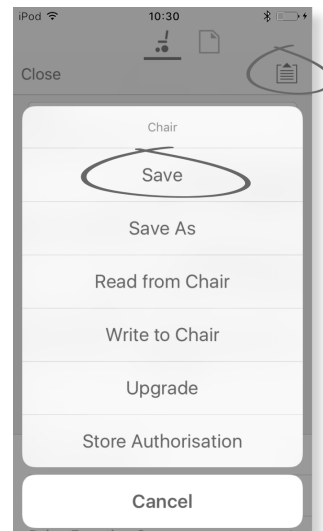

1. Click on **Application menu** button.
2. Select **Save**.



3.

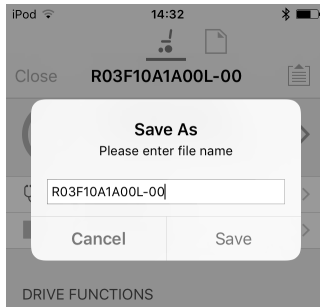

When using **Connection context mode**, a **Save As** menu opens up automatically. Enter a file name or the program prompts the current program name with “-1” if already existing.

- After saving the program, the LiNX Access tool displays a message with the file’s name and that saving was successful.
- Click on **Dismiss** to remove the message and continue.



All files are saved with a .lci extension. If the Program name has been set, then the file is saved with the Program Name. If not, the file is saved with a date /time stamp as follows:

YYYYMMDD-HHMMSS.lci (YYYY is year, MM is month, DD is day, HH is hour, MM is minute, SS is second). Subsequent saves will retain the last saved file name and overwrite previously saved files. To save a file without overwriting an existing file, us **Save As**, refer to .



The **Application menu** dialogue in this picture shows all available options, when you are in **Connection context**. In **File context** the selection is more limited.

### Using Save As

To save a program as file with a different name.

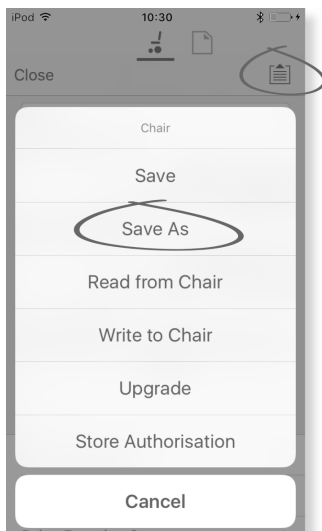

- Click on **Application menu** button.
- Select **Save As**. After saving the program, the LiNX Access tool displays a message with the file’s name and that saving was successful.
- Click on **Dismiss** to remove the message and continue.



All files are saved with a .lci extension. If the file has not been saved before, and if the program name has been set, then the file is saved with the program name. If the file has been saved before with the program name, then the file is saved with a numerical value appended to the program name. If the program name has been set, then the file is saved with the program name. If not, the file is saved with a date / time stamp as follows: YYYYMMDD-HHMMSS.lci (YYYY is year, MM is month, DD is day, HH is hour, MM is minute, SS is second).



The **Application menu** dialogue in this picture shows all available options, when you are in **Connection context**. In **File context** the selection is more limited.

### 7.3.8 Upgrading firmware

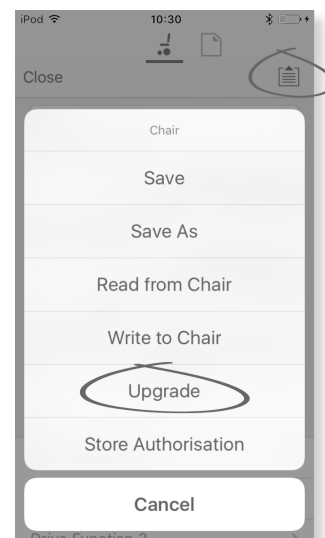

- Click on **Application menu** button.
- Click on **Upgrade**. The screen displays **Entering Firmware Upgrade Mode – please wait...** If the connected modules are up to date, the screen displays **FIRMWARE UP TO DATE** with a list of the connected modules and their respective versions. If one or more modules need upgrading, these is displayed under **NEW FIRMWARE AVAILABLE**.

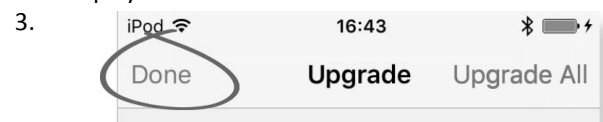

If no modules require upgrading, click **Done** button to finish.

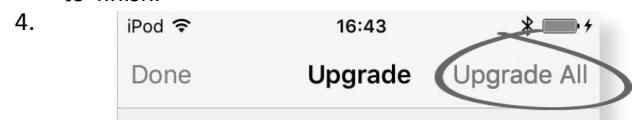

If one or more modules require upgrading, click on single module to upgrade it or click on **Upgrade All** button.

During a module upgrade, a progress bar is displayed. Once the upgrade has completed, its status is displayed (succeeded or failed) to the side of the module name.

- Click **Done** button to finish.

### 7.3.9 Storing the LAK certificate

The **Access Level Certificate** determines how you view and edit offline programs (.lci files) when in the **File context** mode. The **Access Level Certificate** is taken from a connected LiNX Access Key and provides the levels to your stored files.

To edit your files with a distributor’s access level, you will need to store an **Access Level Certificate** from a distributor-level LiNX Access Key.

If you do not store your **Access Level Certificate** from your LiNX Access Key, you have read-only access to your stored files and you are not able to edit them.

#### Storing the certificate

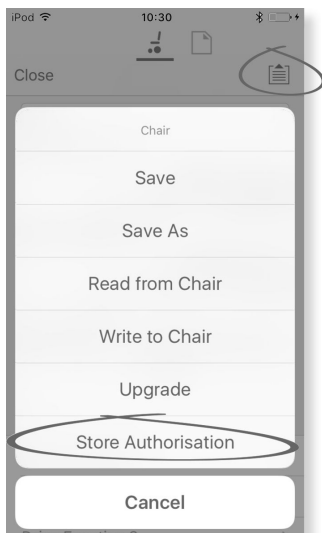

1. Connect to LiNX system.
2. Click on **Application menu** button.
3. Select **Store Authorisation** option. A message is displayed showing how many authorizations remain and if you want to continue. LiNX Access Keys only permit three **Store Authorisation** operations.
4. Click on **Store option** to continue or **Don't store** to cancel the action.

 If the LiNX Access iOS tool application is removed from your iOS device, the **Access Level Certificate** is lost.

## 7.4 File context actions



The following tasks are only relevant when in the **File context** mode. For tasks related to the **Connection context** mode, refer to 7.3 *Connection context actions, page 62*.

### 7.4.1 Load from file screen

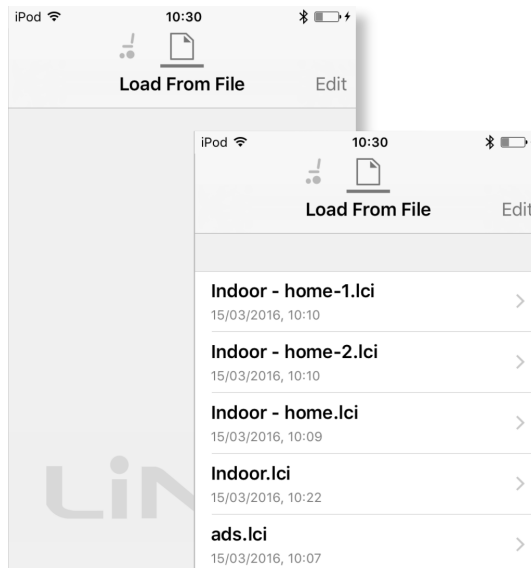

The **Load from file** screen is displayed when you are in **File context** before opening a file. If LiNX configuration files (.lci) exist on your device, then they are displayed. From this screen you can:

- View the available configuration files
- Open a configuration file for editing
- E-mail a configuration file
- Delete a configuration file

### 7.4.2 Writing Bundle Files

Bundle files can be written to a connected chair. Bundle files can include wheelchair configurations and/or firmware files.

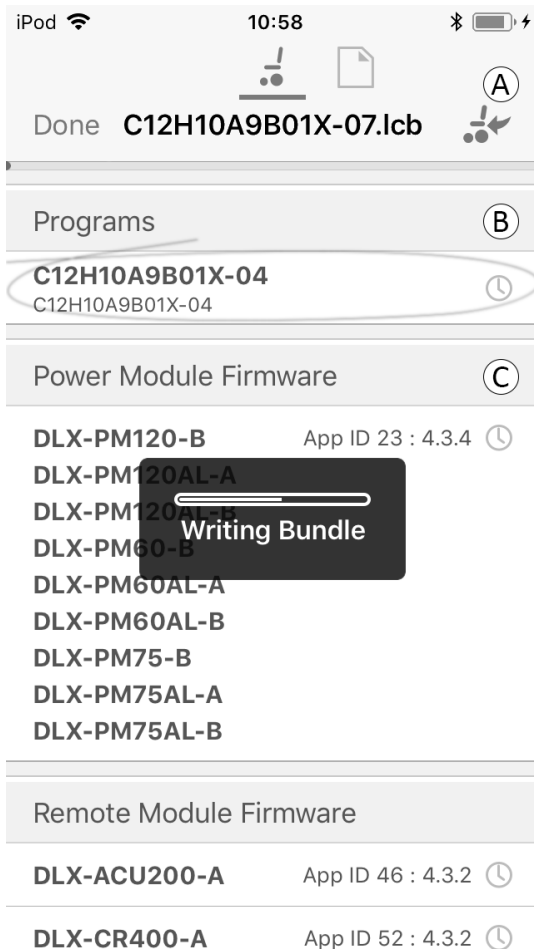

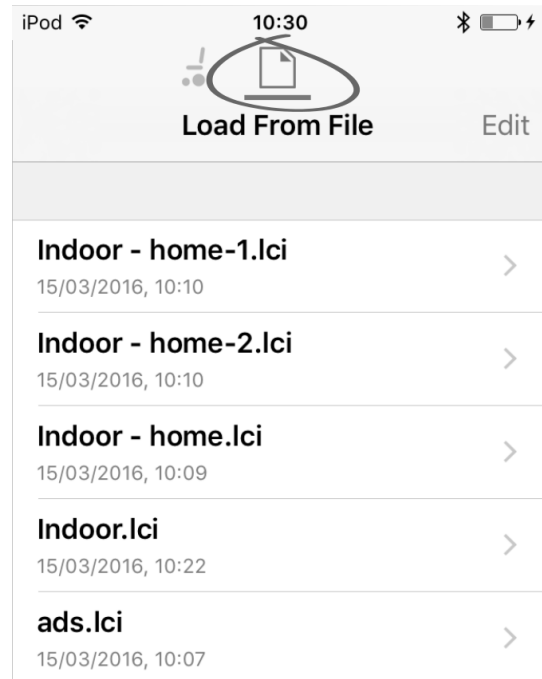

Fig. 7-7

1. Connect wheelchair.
2. Select File connection screen.
3. Choose bundle file from list displayed in Load From File screen.
4.
  -  Ensure to select the correct configuration. A wrong configuration can lead to unexpected behaviour and failures. For more information about the rules for program naming, see *12 Structure of Program Names, page 113*
5. Select preferred configuration from section **B**.
6. Check included firmware versions of components in section **C** and below.
7. Write bundle file to wheelchair. Click button **A** and wait until overlay Writing Bundle disappears.
8. Click button Done to return to File connection screen.

### 7.4.3 Opening files



1. Select **File connection** screen.
2. Choose file from the list displayed in the **Load From File** screen.

For information about saving files and writing to a wheelchair refer to *9.5.4 Save a program as a file, page 89* and *7.3.6 Writing a program to the wheelchair, page 64*.

### 7.4.4 Deleting files

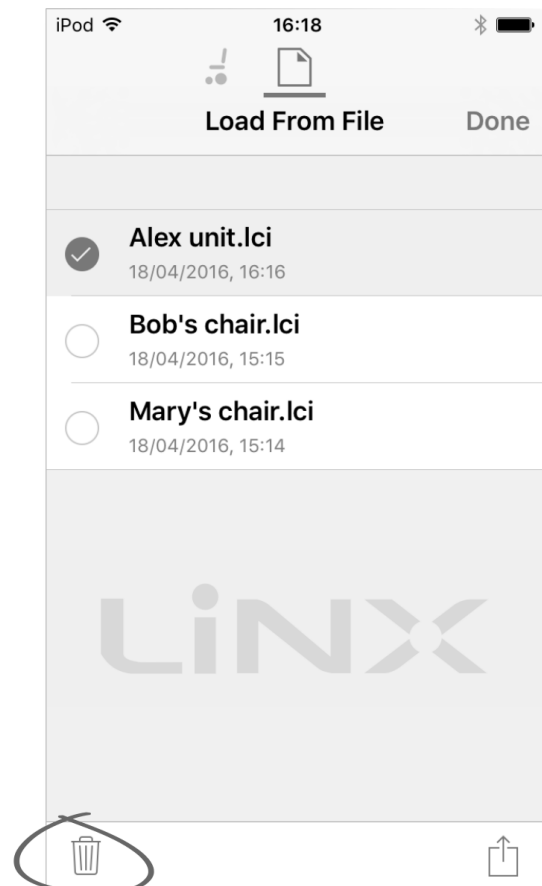

1. Select **Edit** from **Load from File** screen.
2. Select one or more files from the file list.

3. Click on trash can icon at the bottom of the screen.
4. Click on **Done** to finish.

### 7.4.5 E-mailing files

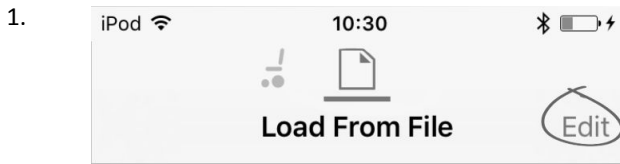

2. Select **Edit** from **Load From File** screen.
3. Select one or more files from file list.

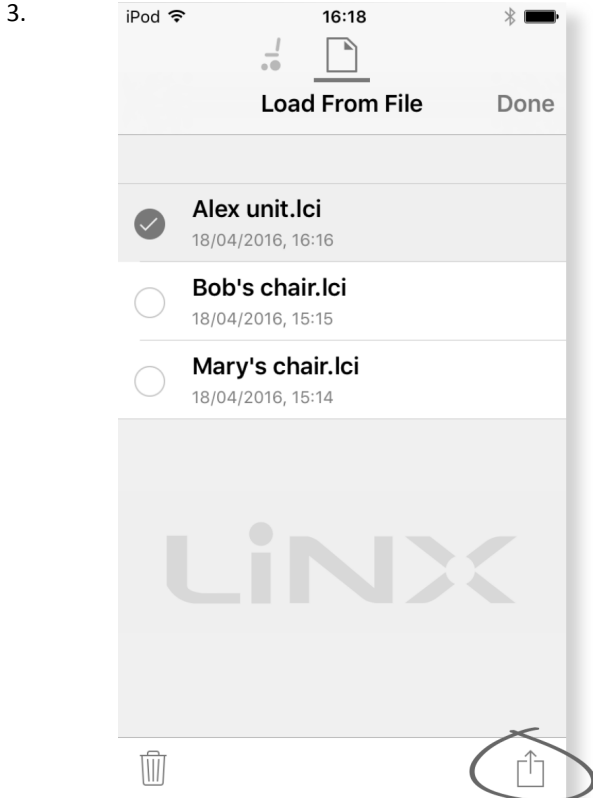

Click on **E-mail** button.

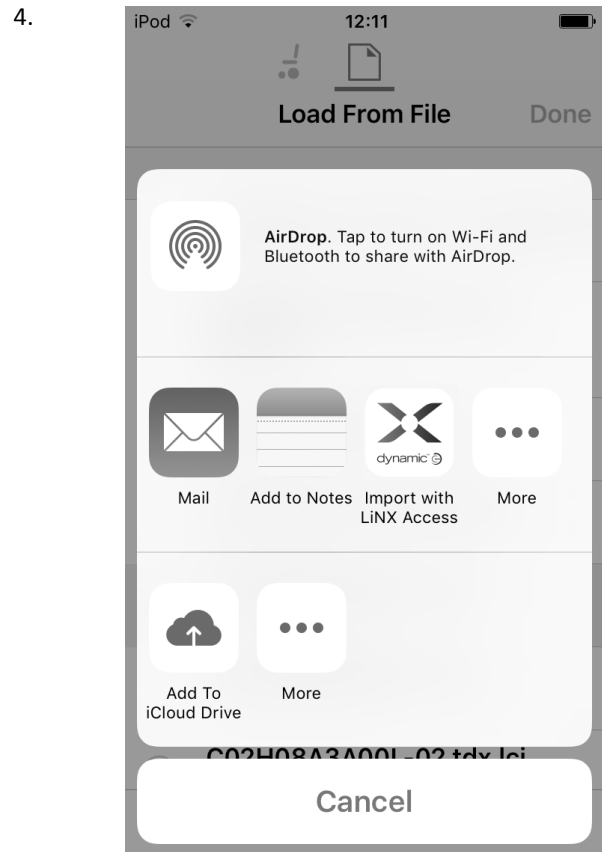

The iOS Share Sheet opens up. Select desired option.

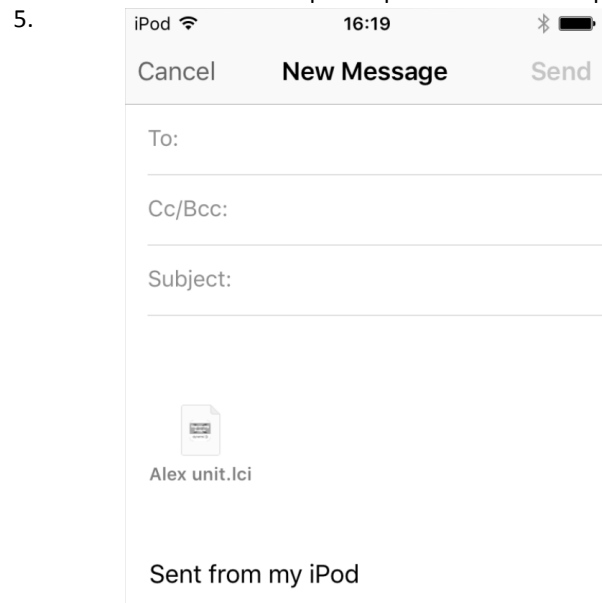

If you choose your mail client, selected program files are added as attachments to e-mail. Complete e-mail and click on **Send**.

6. Click on **Done** to finish.

# 8 Modifying wheelchair configuration with iOS tool

## 8.1 Profile And Function Actions

In bulk edit mode:

- profiles can be added and deleted,
- functions can be added, deleted, duplicated and moved.

 A system always includes a REM2xx Drive Function profile and a REM2xx Seating Function profile. These cannot be moved or deleted.

### Screen Overview

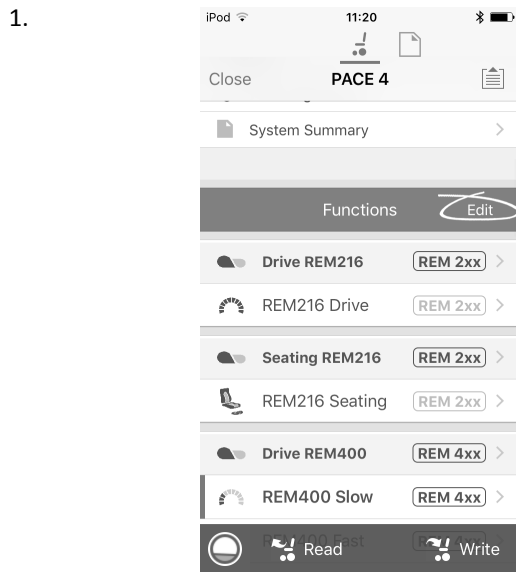

Tap **Edit** in functions title bar.

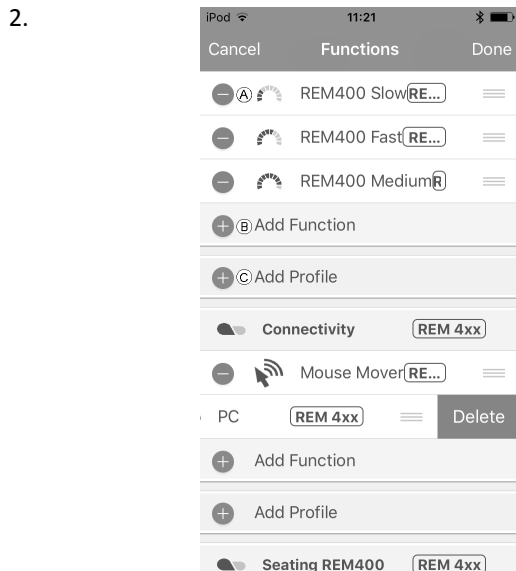

Select desired profile or function action.

- Ⓐ Delete function or profile
- Ⓑ Add function
- Ⓒ Add profile

3. Tap **Done** to return to **Home** screen.

### Add Profile

1. Tap on icon **Ⓒ**.

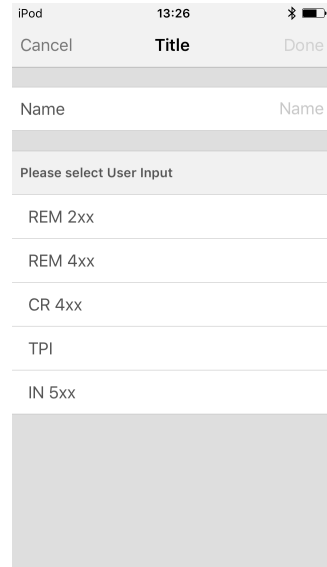

Enter profile name.

Select **User Input**.

2. Add function to profile.

3. Tap **Done** to return to **Home** screen.

 User Navigation Error is displayed as long as no function is added to the new profile.

### Add new Function

1. Tap on icon **Ⓑ**.

2.

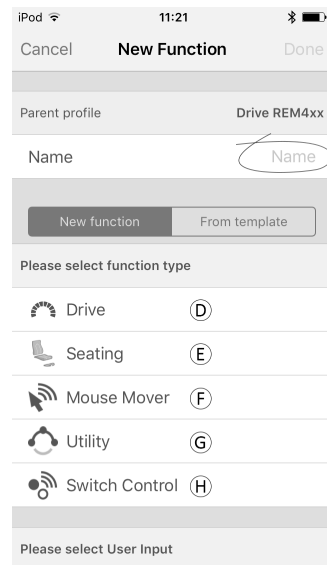

Fig. 8-1

Enter function name.

3. Select **function type**.

Tap on icon **Ⓓ** to add drive function.

Tap on icon **Ⓔ** to add seating function.

Tap on icon **Ⓕ** to add mouse mover function.

Tap on icon **Ⓖ** to add utility function.

Tap on icon **Ⓗ** to add switch control function.

4.

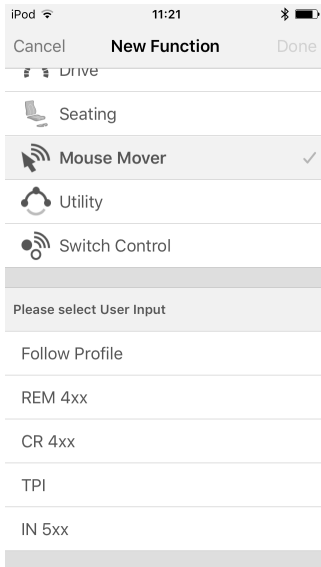

Fig. 8-2

Select **User Input**.  
Tap **Done**.

5. Tap **Done** to return to **Home** screen.

For more information about modifying the drive parameters, see *8.3 Modifying drive parameters graphically, page 72*.

For more information about modifying the seating parameters, see *8.8 Modifying Seating Parameters, page 74*.

For more information about setting up a mouse mover or switch control, see user manual of remote.

**Add new Function From Template**

1. Tap on icon **B**.
2. Enter function name.
- 3.

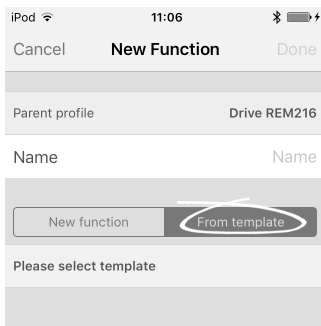

Fig. 8-3

Tap **From template**.  
Select desired template.  
Tap **Done**.

**Duplicate Function**

1. Tap on function you want to duplicate.
- 2.

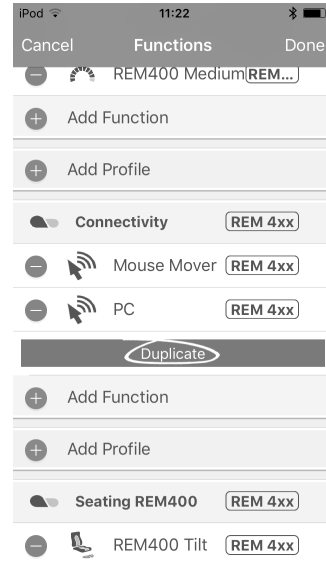

Fig. 8-4

Tap on **Duplicate**.

duplicate function appears directly under original function.

**Move Function**

Functions can be reordered by dragging and dropping inside a profile or between profiles.

1.

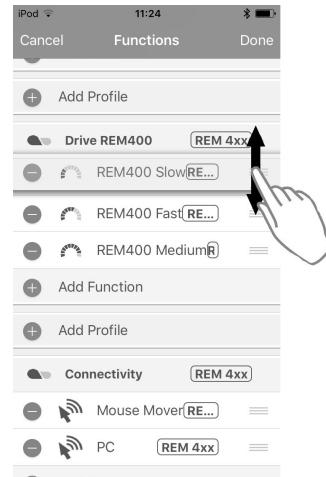

Fig. 8-5

Tap and hold function you want to move.  
Function moves slightly up and to the right.

2. Drag function to required position in same or another profile.

**Delete Function or Profile**



A profile cannot be deleted until its functions are deleted.

1. Select function or profile you want to delete.
2. Tap on icon (A).
- 3.

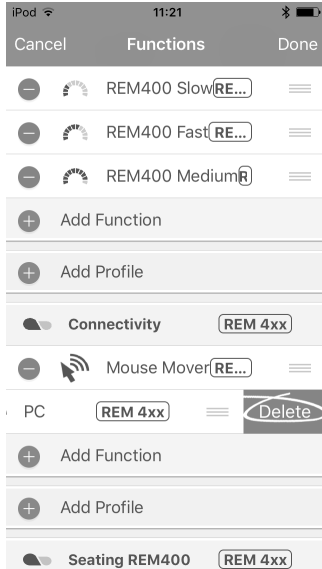

Fig. 8-6

Confirm action with tapping **Delete** button that appears next to function or profile.

**Delete or Duplicate Function (Quick Access)**

1. Select function you want to delete or duplicate from **Home** screen.
- 2.

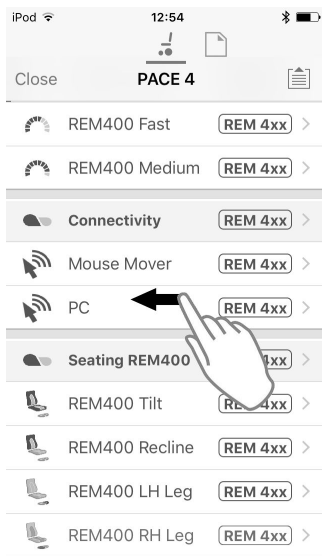

Fig. 8-7

Tap and pull function to left.

- 3.

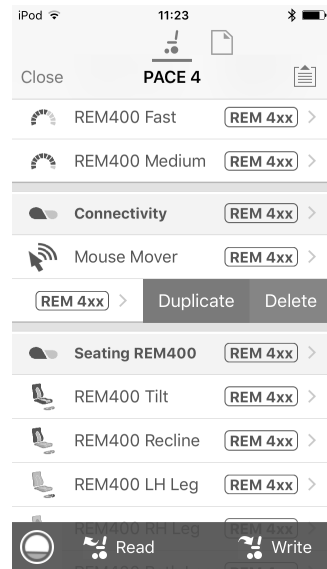

Fig. 8-8

Tap **Duplicate** or **Delete**.

- 4.

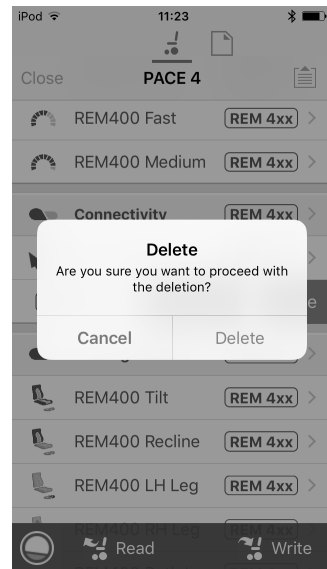
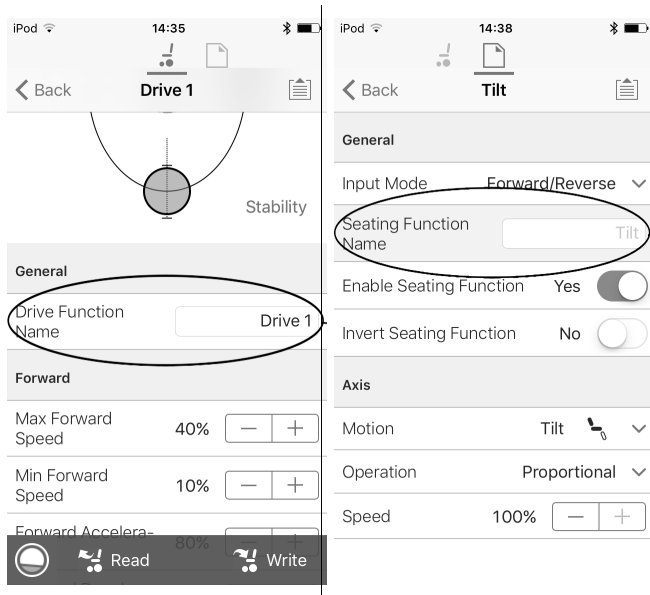

Fig. 8-9

Confirm, if you want to delete function. Otherwise, click **Cancel**

## 8.2 Modifying function and profile names

### Function names



1. Open Drive or Seating function. Tap on field with function name.

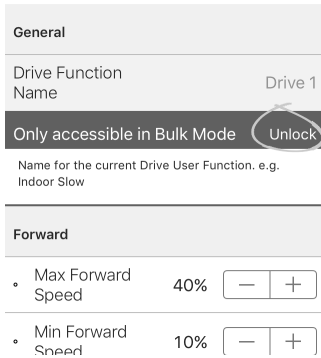
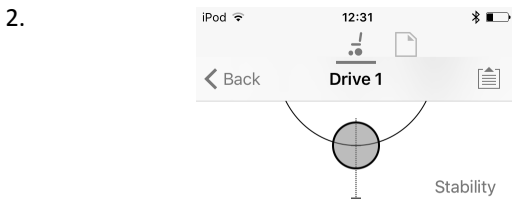

3. Unlock **Bulk Mode** before modifying the name.
3. Enter new name.

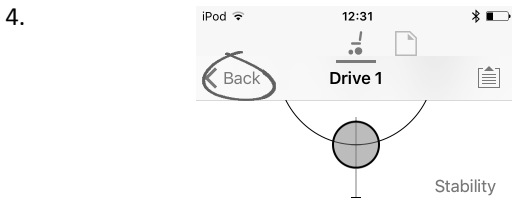

Tap on **Back**.

### Profile names

- 1.

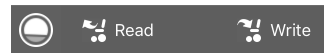
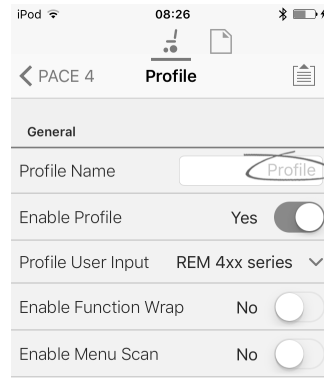

- Open profile. Tap on field with function name.
2. Enter new name.
3. Tap on **Back**.

## 8.3 Modifying drive parameters graphically

A number of drive parameters can be edited graphically only with the iOS Access Tool. The speed graph is shown at the top of the parameter list. All other graphs are accessed from this screen, as detailed in the following sections.

### Editing speed settings

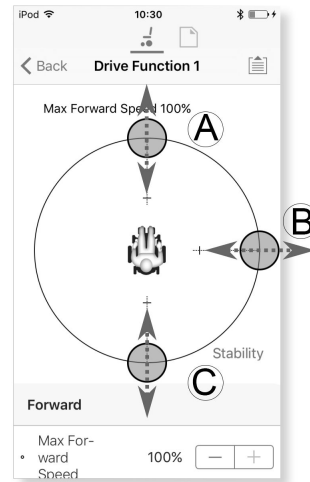

The Speed graph allows you to adjust:

- **Maximum Forward Speed** (A)
- **Maximum Turn Speed** (B)
- **Maximum Reverse Speed** (C)

1. Tap and drag the colored circles inwards or outwards to decrease or increase parameter values.

The exact value for each parameter is shown at the top of the screen when adjusting the parameter and it is also displayed in the parameter list.



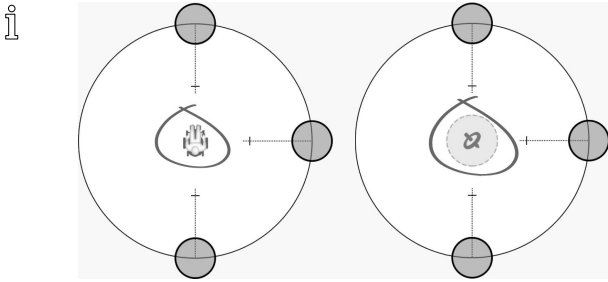

If a gyro module is enabled, the graphic in the center of the graph changes from a person in a wheelchair to a gyroscope to indicate that the parameter being changed are gyro-specific.

### Editing acceleration / deceleration settings

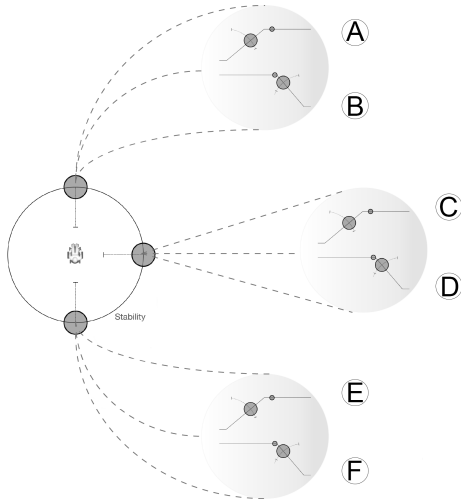

The acceleration / deceleration parameters are only accessible through the Speed graph screen. To edit one of the acceleration or deceleration settings, press and hold one of the colored circles in the Speed graph screen.

- Press and hold the **Max Forward Speed** circle to be taken to the Forward acceleration **A** / deceleration **B** screen.
- Press and hold the **Max Turn Speed** circle to be taken to the Turn acceleration **C** / deceleration **D** screen.
- Press and hold the **Max Reverse Speed** circle to be taken to the Reverse acceleration **E** / deceleration **F** screen.

For each acceleration / deceleration parameter, the acceleration value can be modified with the upper graph, the deceleration value can be modified with the lower graph.

1. Press and drag the colored circles to decrease or increase the parameter values. All changes to the acceleration / deceleration values are displayed at the top of the screen.

## 8.4 Modifying drive parameters numerically

All drive parameters can be edited numerically.

1. Select a parameter to edit.
2. Click on the parameter's name to open the parameter's details. Default, minimum and maximum values will be displayed, as well as the parameter's summary.
3. There are different ways to modify the parameters:

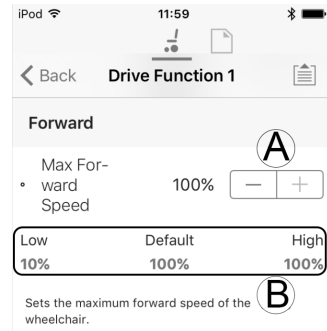

- a. Increment and decrement the parameter with the plus (+) and minus (-) buttons **A**. Click these buttons to change the value in discrete steps or click and hold the buttons to change the value more quickly.
- b. Set the parameter value by clicking on the **Low**, **Default** or **High** buttons **B**.

**i** When you edit a parameter's value, its background color will change to indicate that it has changed from its previous value. Once the value is written to the controller (or file), the background will revert to white.

**i** When in live edit mode, it might be difficult to see the parameter background changing since the live edit operation can take place very rapidly.

## 8.5 Modifying Lighting Parameters

When installing lighting system, replacing power module or resetting default configuration from power module it can be necessary to adjust lighting settings. In some configurations lighting functions are disabled by default and need manual activation.

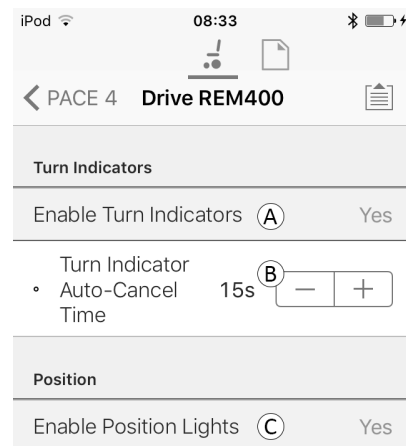

Fig. 8-10

1. From **Home screen** click on **Lighting**.
2. Edit parameters according following table.

	Parameter	Description	Values
Ⓐ	Enable Turn Indicators	Allows system to use turn indicators	No / Yes
Ⓑ	Turn Indicator Auto-Cancel Time	Sets length of time a turn indicator will be on before being automatically turned off	0 s ... 30 s
Ⓒ	Enable Position Lights	Allows system to use position lights	No / Yes

### 8.6 Modifying Gyro Support in Drive Functions

By default, Gyro support is enabled in drive functions. The following instructions show you how to disable the Gyro support for drive functions or to hide the Gyro symbol on screen if no Gyro is installed on wheelchair.

1. From **Home screen** open desired drive function.
- 2.

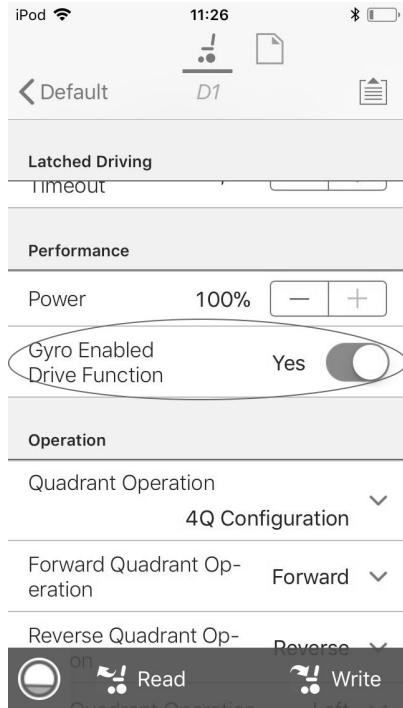

Fig. 8-11

Set **Gyro Enabled Drive Function** to **Yes**, to provide enhanced stability control for this drive function. Otherwise, set to **No** to disable gyro support for this function.

### 8.7 Programming Toggle Switches

At the moment the programming is reserved for the PC tool.

Please use the PC tool instead.

## 8.8 Modifying Seating Parameters

### Trigger Angles

Angle sensor-triggers allow you to modify factory default angle triggers of wheelchair to accommodate specific user needs.

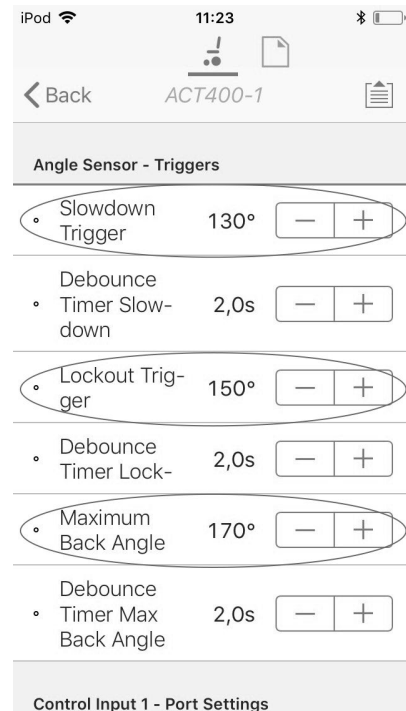

Fig. 8-12

Parameter	Description
<b>Slowdown Trigger</b>	Sets the angle sensor's trigger angle to slow down the driving speed
<b>Lockout Trigger</b>	Sets the angle sensor's trigger angle to lock out drive
<b>Maximum Back Angle</b>	Sets the angle sensor's trigger angle to stop further movement of the backrest.

1. From **Home screen** click on **Chair Setup**.
2. Click on **Modules** and select your type of actuator module, for example ACT400-1.
3. Set parameters to user's needs.

### Seating Motion

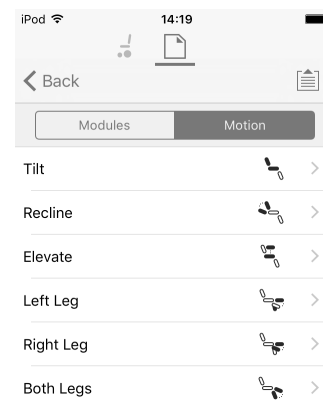

Fig. 8-13

1. From **Home** screen click on **Chair Setup**.
2. Click on **Motion**.
3. Select seating motion you want to change.

**Changing Motion Name**

1.

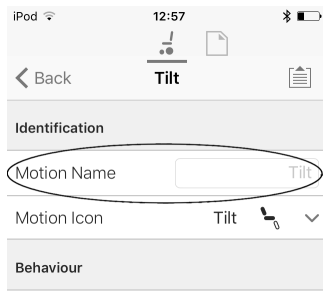

Fig. 8-14

1. Tap on field **Motion Name**.
2. Unlock **Bulk Mode** before modifying name.
3. Tap on **Back**.

**Seating Function**

This parameter sets how the joystick operates a motion. The joystick can control the motion as a switch or as a proportional controller. There are four switch-type modes and one proportional-type mode.

1. From **Home** screen open desired seating function.
  - a.

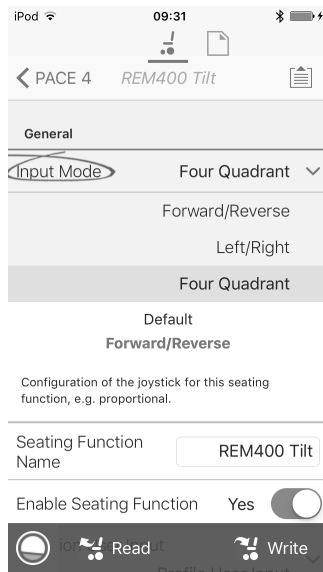
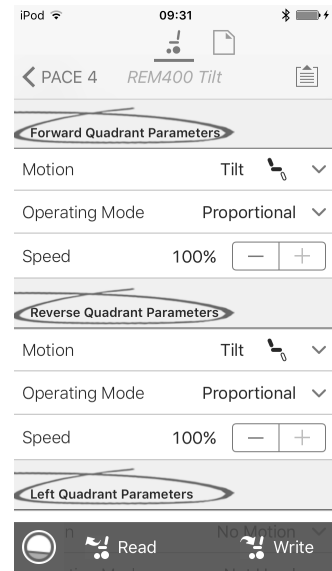

Fig. 8-15

**Input Mode:** Configuration of user input for this seating function.

- **Forward/Reverse:** Moving joystick forward or reverse to control motion.
- **Left/Right:** Moving joystick left or right to control motion.
- **Four Quadrant:** Using all four joystick quadrants to control motions.



If **Four Quadrant** is selected, all quadrant parameters can be edited individually.

b.

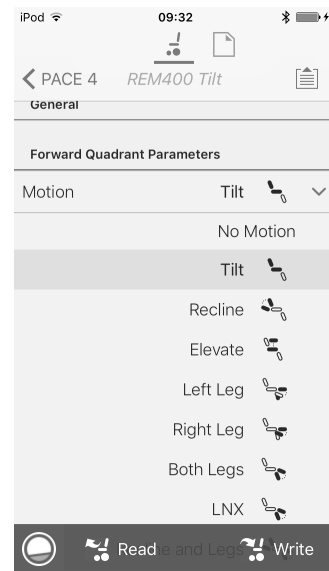

Fig. 8-16

**Motion:** If the joystick is used to control a motion, then select the motion from the list of available motions.

If the joystick is not used to control a motion, then select **No Motion** from the list.

c. **Operating Mode:**

Switch-type	Proportional type
Switched	Proportional
Latched	
Toggle	
Toggle / latch	

Choose one of the switch-type modes to operate the motion at a fixed speed. The motion is activated when the joystick is deflected past the **Joystick Switch Threshold** ⑥ into either the forward ④ or backward ⑤ quadrants. Refer to *8.10 Joystick Switch Threshold, page 77* how to modify the **Joystick Switch Threshold**.

Choose the proportional-type mode to operate the motion at a speed that is proportional to the joystick's position. The motion is activated when the joystick is deflected out of neutral into either the forward ④ or backward ⑤ quadrants. If the joystick is not used to control this motion, then set this parameter to Not Used.

Operation	Purpose
Switched	Activates the motion in the extend / retract direction for the duration that the joystick is deflected forwards / backwards and its position is greater than Joystick Switch Threshold. The motion is deactivated when it reaches its end-of-travel or when the joystick's position is less than the Joystick Switch Threshold.
Latched	Activates and latches the motion in the extend /retract direction when the joystick is momentarily deflected forwards / backwards across the Joystick Switch Threshold. The motion is deactivated when the motion reaches its end-of-travel or the joystick is deflected again across the Joystick Switch Threshold.
Toggle	Activates the motion in one direction (extend or retract) for the duration that the joystick's position is greater than Joystick Switch Threshold. The motion is deactivated when it reaches its end-of-travel or when the joystick's position is less than Joystick Switch Threshold. The direction of the motion toggles between extend and retract for each new activation.

Operation	Purpose
Toggle / latched	Activates and latches the motion in one direction (extend or retract) by momentarily deflecting the joystick across the Joystick Switch Threshold. The motion is deactivated when the motion reached its end-of-travel or the joystick is deflected again across the Joystick Switch Threshold.
Proportional	Deflecting the joystick forwards /backwards activates the motion in the extend / retract direction for the duration that the joystick is deflected. The motion is deactivated when it reaches its end-of-travel or when the joystick is returned to the neutral position. The speed of this motion is controlled by the amount of deflection from the neutral position and scaled further by using the Speed parameter.
Not Used	No operation.

- d. **Speed:** For the switch-type operations (Switched, Latched, Toggle, Toggle / latched), this parameter applies the speed of the motion when the joystick crosses the **Joystick Switch Threshold**. For the proportional operation, this parameter sets the maximum speed at which the motion will travel when the joystick is deflected to 100 % of its travel. For all other positions of joystick deflection the applied speed will be scaled down accordingly.

## 8.9 Modifying Attendant Parameters

Attendant profiles allow an attendant to control drive functions and seating functions of wheelchair. Currently two User Inputs are available, Attendant Control Unit (DLX-ACU200) and Intuitive Dual Control (Invacare IDC).

### Attendant Control Unit (DLX-ACU200)

Input allows programming drive functions and seating functions. Parameters of functions are identical to primary remotes. See *8.3 Modifying drive parameters graphically, page 72*, *8.4 Modifying drive parameters numerically, page 73* and *8.8 Modifying Seating Parameters, page 74*.

### Intuitive Dual Control (Invacare IDC)

Input allows programming maximum one drive function.



### Add New Attendant Function

 Tool allows you to add all function types to Attendant profile. In case of an invalid function, like Switch Control, you will get error prompt with further instructions to solve error.

1. Open **Functions**.
2. Select profile **Attendant** from list. Otherwise, both user inputs are not available.
3. Add new function. See *8.1 Profile And Function Actions, page 69*.
4. Modify other parameters.

### 8.10 Joystick Switch Threshold

Sets the percentage of joystick movement required to activate an output when the joystick is operating as a switched input device.

When the joystick is used as a switched input device, this parameter specifies how far the joystick has to be pushed before its state changes (OFF  to ON ) and activates an output. The **Joystick Switch Threshold** value is a percentage of the joystick's full travel and should be set according to the user's needs. For example:

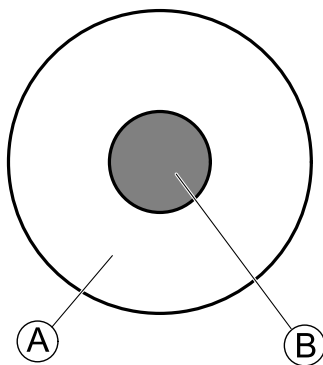

for users that have difficulty moving the joystick, set **Joystick Switch Threshold** to a low value, such as 40 % or less,

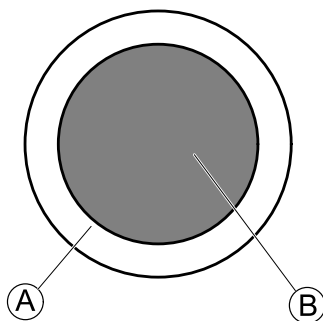

for users that lack fine motor control or are subject to hand tremors, set **Joystick Switch Threshold** to a high value, such as 80 %, to avoid unintentional switching.

1. From **Home** screen click on **Chair Setup**.
2. Click on **Modules**.

3. Click on **Remote**.

- 4.

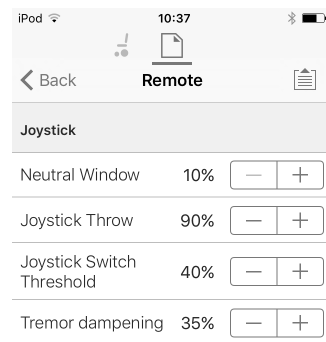

Set the desired percentage.

#### Tremor dampening

Use this parameter to reduce the effect of hand tremors on the joystick. Low values are suitable for users with low frequency (slow) tremors. Higher values will suit users with higher frequency (fast) tremors. Setting the parameter value to 0 % results in no tremor dampening.

### 8.11 Adjust quadrant operation

This parameter sets the drive function's user input to operate in 3-quadrant (3Q) or 4-quadrant (4Q) mode. Typically, the 4Q mode is chosen with joystick-based inputs or arrays, that provide 4 quadrants, for example, a Sip and Puff array. The 3Q mode is chosen for user inputs that provide 3 quadrants, for example, a head array.

1. From **Home** screen open desired drive function.

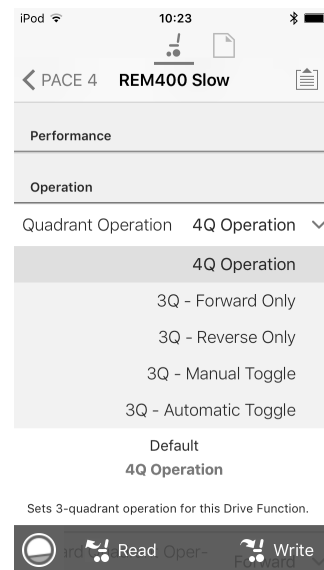

The options are:

- **4Q Operation**
- **3Q - Forward Only**
- **3Q - Reverse Only**
- **3Q - Manual Toggle**
- **3Q - Automatic Toggle**

#### 4Q Operation

When **4Q Operation** is selected, each quadrant is assigned a unique direction from forward, reverse, left and right, this is the default mode. To change these default directions, the quadrants can be reassigned with a different direction by setting the following parameters:

- **Forward Quadrant Operation**
- **Reverse Quadrant Operation**

- **Left Quadrant Operation**
- **Right Quadrant Operation**

It is not necessary that all quadrants are assigned unique directions. If required, one or more quadrants can share the same direction. For example, **Forward Quadrant Operation** and **Reverse Quadrant Operation** can both be set to **Forward**. For more information about adjusting the drive direction, refer to *8.11.1 Adjust drive directions*, page 78.

### 3Q - Forward Only

When **3Q - Forward Only** is selected, the user input can drive the wheelchair forward, left and right.

If required, each quadrant can be reassigned with a different direction. Note that the **Reverse Quadrant Operation** parameter is not applicable in **3Q - Forward Only** mode.

### 3Q - Reverse Only

When **3Q - Reverse Only** is selected, the user input can drive the wheelchair reverse, left and right.

If required, each quadrant can be reassigned with a different direction. Note that the **Reverse Quadrant Operation** parameter is not applicable in **3Q - Reverse Only** mode.

### 3Q - Manual Toggle

When **3Q - Manual Toggle** is selected, the user input can drive the wheelchair forward, reverse, left and right. The forward and reverse directions are controlled by the user toggling an external switch.

If required, each quadrant can be reassigned with a different direction. Note that the **Reverse Quadrant Operation** parameter is not applicable in **3Q - Manual Toggle** mode.

### 3Q - Automatic Toggle

When **3Q - Automatic Toggle** is selected, the user input can drive the wheelchair forward, reverse, left and right. The forward and reverse directions are controlled by the user toggling the forward quadrant.

If required, each quadrant input can be reassigned with a different direction. Note that the **Reverse Quadrant Operation** parameter is not applicable in **3Q - Automatic Toggle** mode.

## 8.11.1 Adjust drive directions

Latched Driving	
Latch Drive Timeout	00,05
Performance	
Power	100%
Gyro Enabled Drive Function	Yes
Operation	
Quadrant Operation	4Q Operation
Forward Quadrant Operation	Forward
Reverse Quadrant Operation	Reverse
Left Quadrant Operation	Left
Right Quadrant Operation	Right

### Forward Quadrant Operation

This parameter sets the direction that the wheelchair moves when the forward quadrant of the user input is selected. Options available are:

- **Forward**
- **Reverse**
- **Left**
- **Right**
- **Ignored**

If **Ignored** is selected, the wheelchair does not move in any direction when the input's forward quadrant is selected.

### Reverse Quadrant Operation

This parameter sets the direction that the wheelchair moves when the reverse quadrant of the user input is selected. Options available are:

- **Forward**
- **Reverse**
- **Left**
- **Right**
- **Ignored**

If **Ignored** is selected, the wheelchair does not move in any direction when the input's reverse quadrant is selected.

This parameter is not available when **Quadrant Operation** is set to any of the 3Q modes.

### Left Quadrant Operation

This parameter sets the direction that the wheelchair moves when the left quadrant of the user input is selected. Options available are:

- **Forward**
- **Reverse**
- **Left**
- **Right**
- **Ignored**

If **Ignored** is selected, the wheelchair does not move in any direction when the input's left quadrant is selected.

### Right Quadrant Operation

This parameter sets the direction that the wheelchair moves when the right quadrant of the user input is selected. Options available are:

- Forward
- Reverse
- Left
- Right
- Ignored

If **Ignored** is selected, the wheelchair does not move in any direction when the input's right quadrant is selected.

### 8.12 Enable indirect navigation

For the iOS tool, there is only **Menu Scan** with **Navigation Timeout** available at the moment.

Steps 1 and 2 must be made in each desired profile and function.

1. From **Home** screen open desired profile.
- 2.

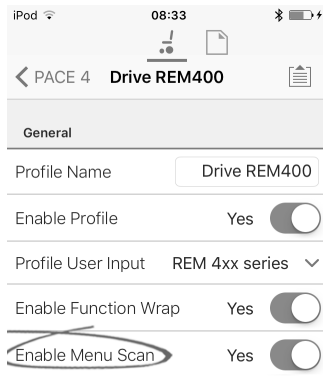

Set **Enable Menu Scan** to **Yes**.

3. From **Home** screen open desired function.
4. Set **Navigation Timeout** to **Yes**.
5. From **Home** screen open **User Preferences**.
- 6.

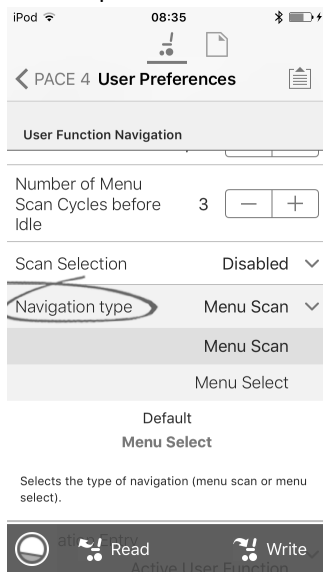

Set **Navigation type** to **Menu Scan**.

### Other parameters

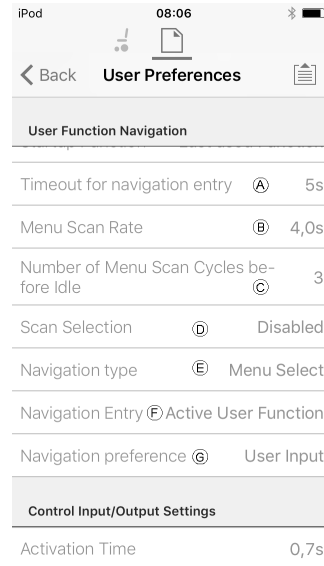

Ⓐ	<b>Timeout for navigation entry:</b> Sets inactivity time required before system enters navigation mode, for navigation mode with <b>Navigation Timeout</b> only.
Ⓑ	<b>Menu Scan Rate:</b> Sets rate at which menu scan iterates through menu, for <b>Menu Scan</b> only.
Ⓒ	<b>Number of Menu Scan Cycles before Idle:</b> Number of times menu is iterated through before going to idle, assuming no user selection, for <b>Menu Scan</b> only.
Ⓓ	<b>Scan Selection:</b> Configures which quadrants of Primary input can be used to make selections, for <b>Menu Scan</b> only.
Ⓔ	<b>Navigation type:</b> Selects type of navigation.
Ⓕ	<b>Navigation Entry:</b> Sets entry point to menu.
Ⓖ	<b>Navigation preference:</b> Selects whether navigation using touch interface has preference over navigation using user input. If user input is selected, display highlights current selection.

### 8.13 Installing / Setting up alternative inputs

There are different types of alternative inputs, that interface differently to the system. Connect the components to the particular inputs, see table below.

Component	Input
Sip and Puff breath tube kit	Input Module IN5xx
Sip and Puff Head Array	Input Module IN5xx
Pediatric Compact Joystick	Input Module IN5xx
Head Array	TPI
Chin control	TPI
Compact Single Switch Joystick	TPI
Four Switch Proximity Array	TPI
Remote Stop Switch	Power Module

 To install a Remote Stop Switch, just connect to the Power Module using the interface cable and the 4-way connector using the Bus cable, see wiring diagram 3.8 *Wiring Diagrams, page 17*. Programming is not necessary.

**Programming**

1. Add new profile or add user function to existing profile. For more information about adding profiles and functions, refer to 8.1 *Profile And Function Actions, page 69*.

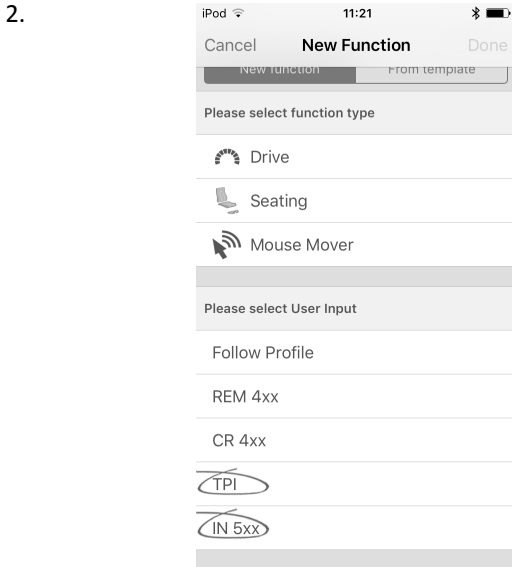

Set **User Input** to **TPI** or to **IN 5xx**, depending on component input.

 Same procedure for drive, seating and connectivity functions.

3. From **Home** screen open **Chair Setup** → **Modules** → **IN 5xx** or **TPI**, depending on component input.

4.

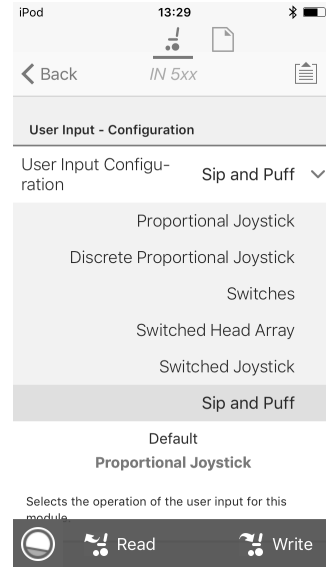

Set **User Input Configuration** to desired component. Options are:

- Proportional Joystick: Pediatric Compact Joystick, Chin Control, Compact Single Switch Joystick
- Discrete Proportional Joystick: not used
- Switches: Four Switch Proximity Array, Sip and Puff Head Array
- Switched Head Array: Head Array
- Switched Joystick: not used
- Sip and Puff: Sip and Puff

5. Depending on component, modify other parameters. For switched inputs, such as Sip and Puff, parameters are found under **User Preferences**, refer to 5.2.1 *Overview User Preferences, page 52*.

 For more information about installing a Sip and Puff, refer to 8.15 *Sip and Puff installation, page 82*.

**8.14 Installing / Setting up Alternative Outputs**

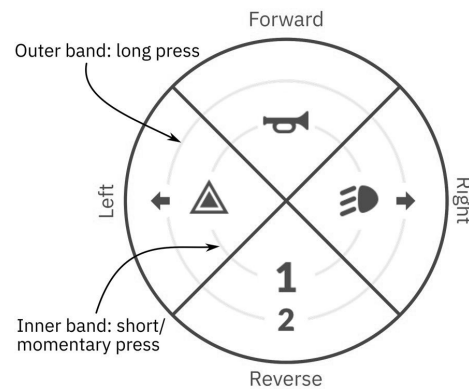

Fig. 8-17 Activation quadrants and bands

The utility function card allows the user to control lighting functions or external outputs using the output module DLX-OUT500. Switches are represented on a utility function card with icons located on two circular activation bands, short/momentary press and long press, within four quadrants (see 8-17 *Activation quadrants and bands, page 80*). The activation time to distinguish between short press and long press can be changed in user preferences, see 5.2.1 *Overview User Preferences, page 52*.



The quadrant and the position of the icons on the bands show the user how to select and operate the switches with their user input.

The following instruction shows you how to program the first control output of DLX-OUT500 using a short/momentary press forwards as an example.

1. Open Functions.
2. Add new utility function or open existing utility function. See 8.1 Profile And Function Actions, page 69.
- 3.

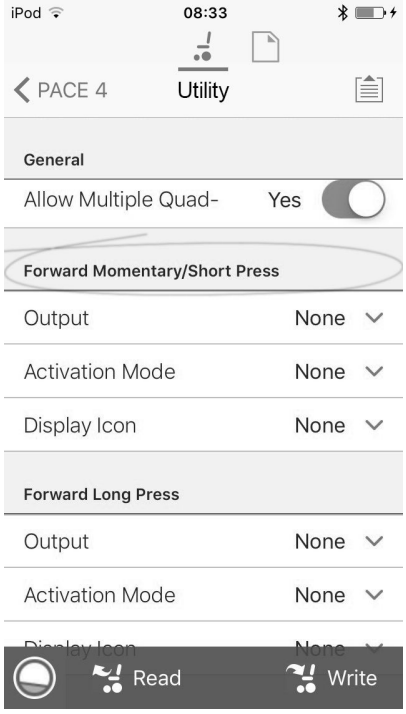

Fig. 8-18

Scroll to section about your desired input command, like Forward Momentary/Short Press.

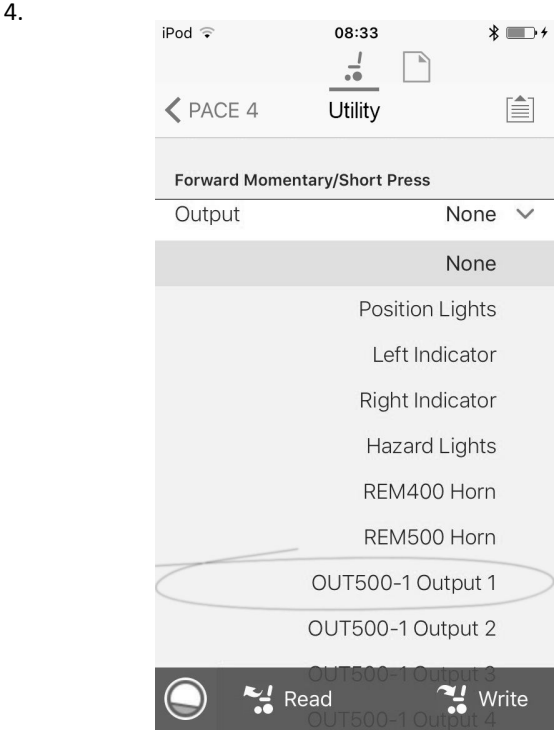

Fig. 8-19

Assign output OUT500-1 Output 1 to parameter Output.

- 5.



Fig. 8-20

Set parameter Activation Mode to desired value. Following modes are available from list:

None	—
Momentary	Activate an output as long as switch is selected. When choosing this mode it is not possible to configure second band for this direction.
Latch ON	Activate an output and remain activated when switch is deselected.
Latch OFF	Deactivate an output and remain deactivated when switch is deselected.
Toggle	Change current output state and remain this new state when switch is deselected.

6.

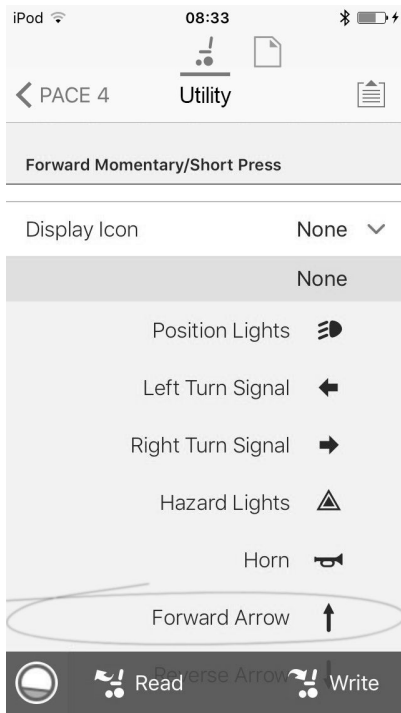
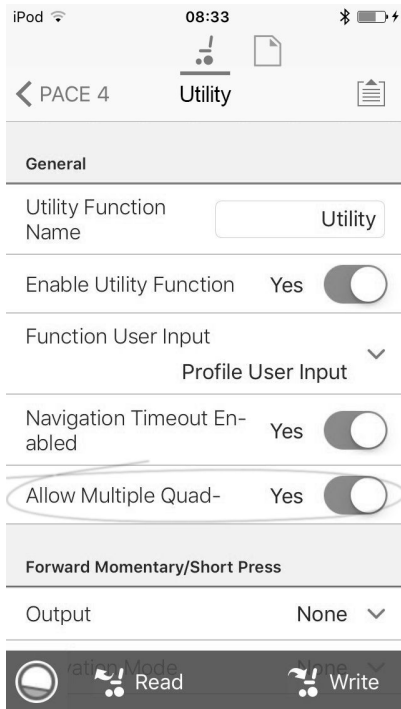

Fig. 8-21

Set parameter Display Icon to desired value. Select a display icon from list of available icons.

7. Modify parameters for other commands.
8. Scroll to section General.
- 9.



Set parameter Allow Multiple Quadrants to On to allow switching two outputs simultaneously.

Fig. 8-22

## 8.15 Sip and Puff installation

A Sip and Puff module is included in the input module.

A Sip and Puff module provides the user with the ability to activate four digital inputs with their breath via a tube depending on pressure level, hard or soft, and direction,

sip or puff. These inputs can be used to control driving or seating actions.

1. Add user function for Sip and Puff module. For more information about adding profiles and functions, refer to *8.1 Profile And Function Actions, page 69*.
- 2.

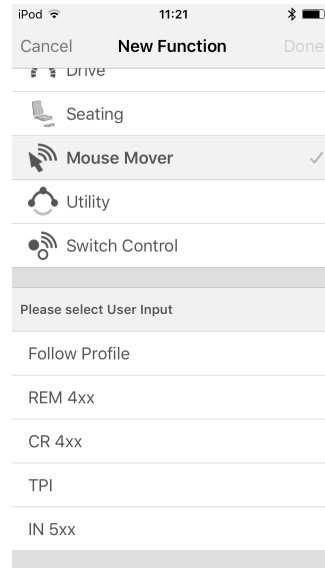

Set User Input to IN 5xx.

 Same procedure for drive, seating and connectivity functions.

3. Open **Chair Setup** → **Modules** → **IN 5xx**.
- 4.

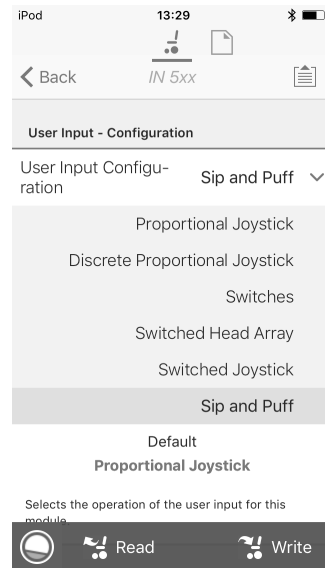

Set User Input Configuration to Sip and Puff.

5. Calibrate Sip and Puff module, refer to *8.15.1 Sip and Puff calibration, page 82*.
6. Open **User Preferences** to adjust veer behavior for switched inputs. For more information refer to *5.2.1 Overview User Preferences, page 52*.

### 8.15.1 Sip and Puff calibration

 Primary input operations, such as driving, are disabled when using the calibration tool. This is for safety reasons to prevent unintended operation when calibrating.

There are three pressure zones for each pressure direction (sip and puff):

- Neutral zone,

- soft zone and
- hard zone.

The Sip and Puff module’s response to a sip or puff input, depends on which zone the pressure falls within: hard or soft. Pressures within the neutral zone are ignored.

Since all users have different capabilities, the Sip and Puff module can be calibrated to change the size and position of these zones. The zones need to be set so that a user can control the wheelchair comfortably and consistently. A Sip and Puff calibration tool is used to determine the pressure thresholds that define the zones. These thresholds are:

- Minimum limit for soft puff,
- minimum limit for hard puff,
- minimum limit for soft sip and
- minimum limit for hard sip.

To calibrate the Sip and Puff module, you have to record pressure measurements from a series of pressure samples performed by the user and adjust the four pressure thresholds accordingly.

1.

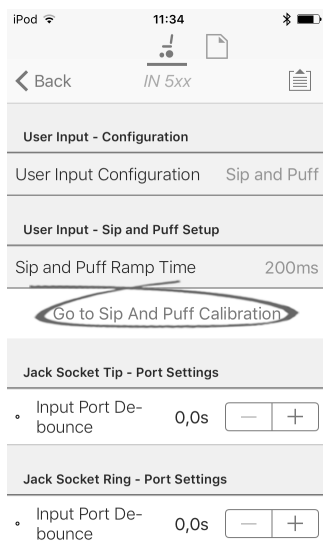

From **Home** screen open **Chair Setup** → **Modules** → **IN 5xx**.

2. Tap on **Go to Sip And Puff Calibration**.

3.

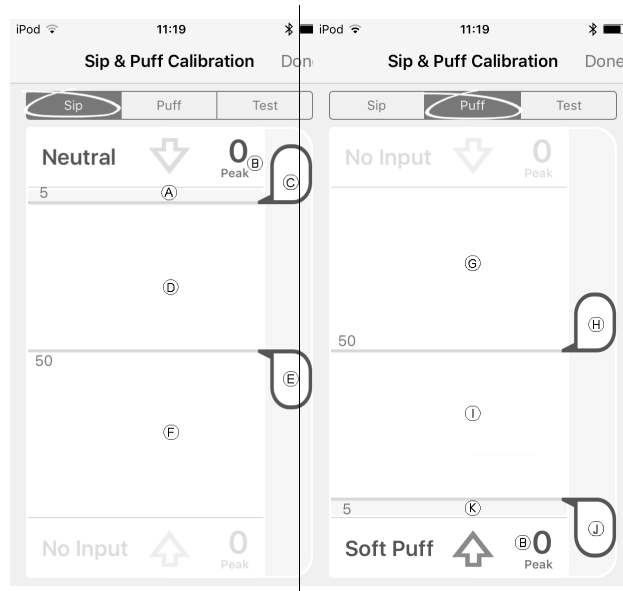

(A)	Neutral zone for sip input
(B)	Pressure level
(C)	Threshold slider to adjust minimum limit for soft sip
(D)	Soft zone for sip input
(E)	Threshold slider to adjust minimum limit for hard sip
(F)	Hard zone for sip input
(G)	Hard zone for puff input
(H)	Threshold slider to adjust minimum limit for hard puff
(I)	Soft zone for puff input
(J)	Threshold slider to adjust minimum limit for soft puff
(K)	Neutral zone for puff input

4. If **Sip** tab is open, user performs hard sip and soft sip in no specific order.  
 If **Puff** tap is open, user performs hard puffs and soft puffs in no specific order.  
 For each sip and puff, a pressure level **B** is recorded on calibration tool. Based on these recorded levels, you determine best level at which to set each pressure threshold.
5. Drag corresponding Threshold sliders.
  - For soft sip, drag threshold slider **C** to position just above user's soft sip. Any subsequent pressure above threshold slider **C** is in neutral zone **A** and is ignored. Pressure below threshold slider **C** and threshold slider **E** is in soft zone **D** and determined as soft sip.
  - For hard sip, drag threshold slider **E** to position just above user's hard sip. Pressure above threshold slider **E** is not considered as hard sip. Pressure below threshold slider **E** is in hard zone **F** and determined as hard sip.
  - For soft puff, drag threshold slider **I** to position just below user's soft puff. Any subsequent pressure below threshold slider **I** is in neutral zone **K** and is ignored. Pressure above threshold slider **I** and below threshold slider **H** is in soft zone **J** and determined a soft puff.
  - For hard puff, drag threshold slider **H** to position just below user's hard puff. Pressure below threshold slider **H** is not considered as hard puff. Pressure above threshold slider **H** is in hard zone **G** and determined as hard puff.

**Sip and Puff Ramp Time**

The **Sip and Puff Ramp Time** defines the amount of time that a pressure input must remain in the soft zone before it is registered as a soft sip or puff. Consequently, it also provides:

- Time for a user to cross from the neutral zone to the hard zone and
- a filter for any noise (unintentionally pressures) at the zone boundaries.

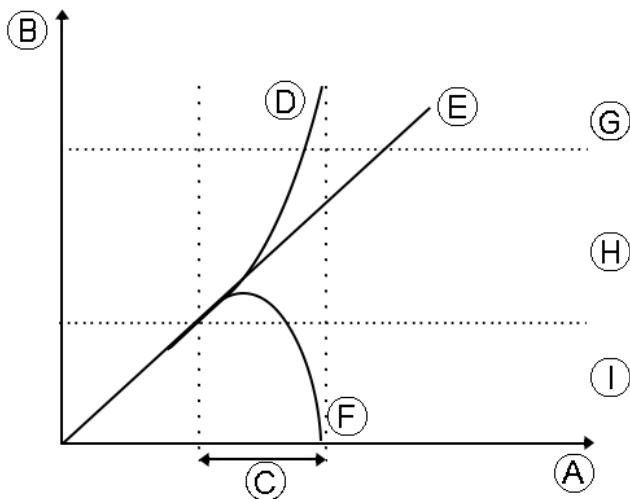

The ramp time **C** begins at the point where the pressure input **D**, **E** or **F** crosses into soft zone **H** — either from neutral zone **I**, when pressure is increasing, or from hard zone **G**, when pressure decreases. A pressure input **D** that reaches the hard zone before ramp time expires, is registered as a hard sip or puff. A pressure input **E** within soft zone at the end of ramp time is registered as a soft sip or puff. Pressure inputs **F** that fall away into neutral zone before ramp time expires are not registered as an input.

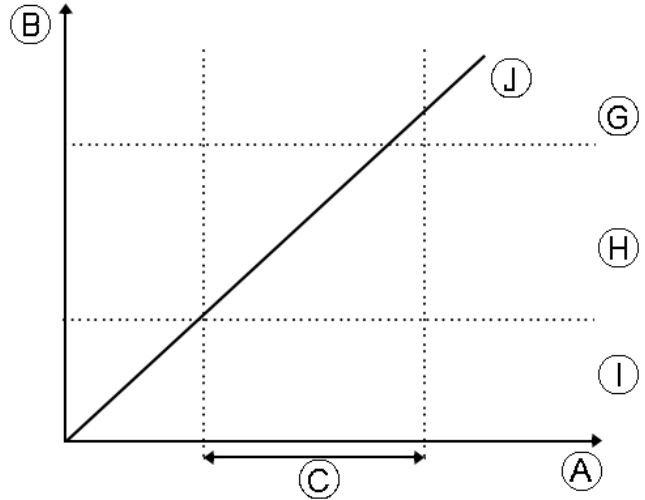

When setting **Sip and Puff Ramp Time**, consideration should be given to users, who cannot produce a hard sip or puff within the ramp time. If ramp time is set too low, a user may not be able to reach the hard zone **G** in time and a soft sip or puff is registered instead of the intended hard sip or puff. For users who need more time to reach hard zone, the ramp time **C** needs to be extended, so the pressure input **J** is registered as a hard sip or puff.

1. From **Home** screen open **Chair Setup** → **Modules** → **IN 5xx**.

2.

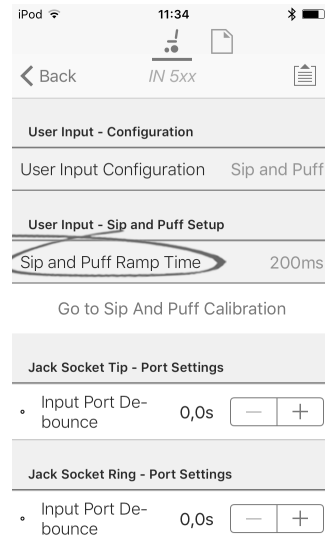

Adjust **Sip and Puff Ramp Time**.

## 9 Using the LiNX Access PC tool

### 9.1 Installing the software

Double-click on the LiNX Access PC tool installation software and follow the on-screen instructions.

#### Step 1

Select the language to use during installation.

1.



Select your choice of language from drop-down box.

2. Click **OK** to continue.

#### Step 2

Before proceeding, make sure that you read and fully understand the Conditions of Use and Warnings presented in the dialogue.

1.

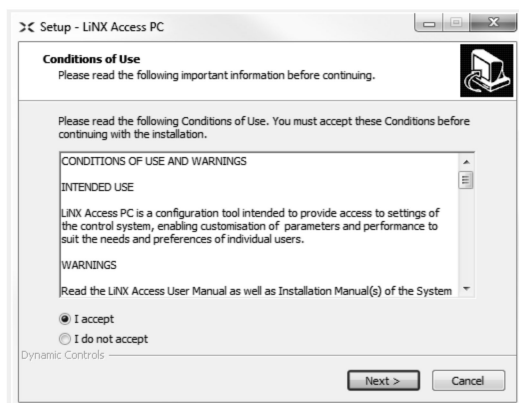

Select **I accept** option.

2. Click **Next** button.

#### Step 3

For your convenience, the application can be saved to an alternative folder instead of the suggested folder.

If the suggested folder is suitable, click **Next** to continue with the set up.

If you want to change the folder:

1.

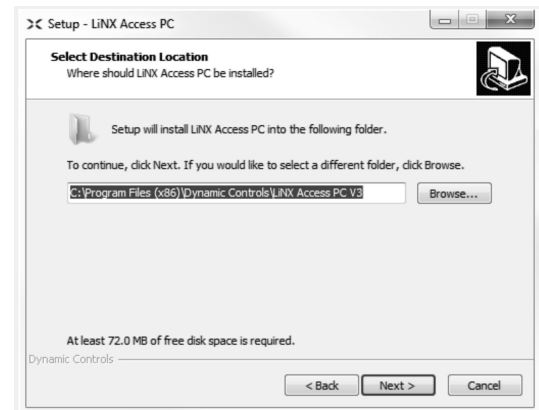

Click on **Browse** button and select different folder.

2. Click **Next** to continue.

#### Step 4

The application's shortcut can be saved to an alternative folder also, instead of the suggested folder.

If the suggested folder is appropriate, click **Next** to continue with the set up.

If you want to change the folder:

1.

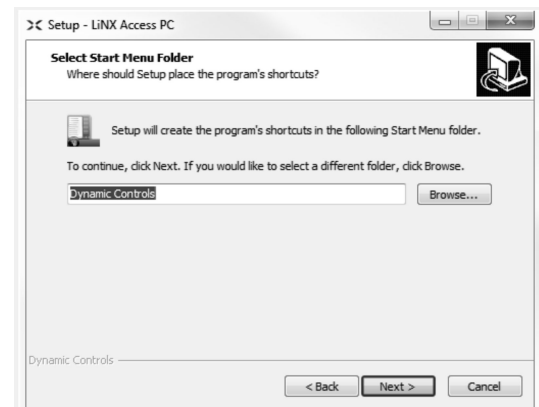

Click on **Browse** button and select different folder.

2. Click **Next** to continue.

#### Step 5

By default, a desktop icon will be added for the LiNX access PC tool and the wheelchair program files (\*.lci) will be associated with the LiNX Access PC tool.

1.

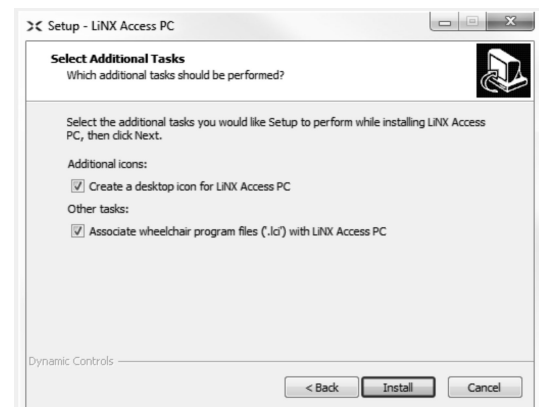

Check / uncheck as appropriate.

2. Click **Install**.

## Step 6

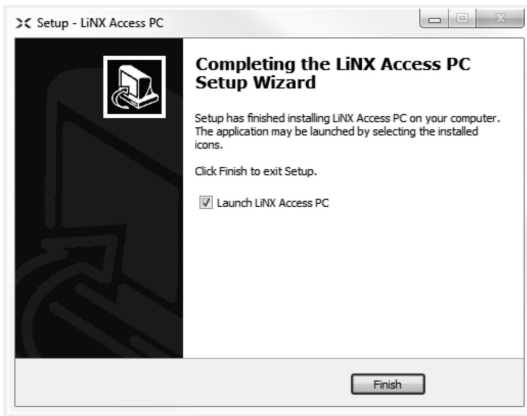

Click **Finish** to complete the installation.

### 9.1.1 Using Bluetooth on a computer

You need a Bluetooth connection to communicate between the LiNX Access PC tool and a LiNX system. You can use a computer's built-in Bluetooth adaptor (usually found on laptops) or an external USB Bluetooth adaptor.

#### Using built-in Bluetooth adaptor

Switch on the built-in Bluetooth adaptor (refer to computer's manual for help on this).

#### Using an USB Bluetooth adaptor

Plug in the external USB Bluetooth adaptor into a spare USB port. The Windows operating system detects and installs the appropriate drivers for the adaptor. Do not install any drivers that may have been provided with the adaptor.

## 9.2 Layout overview

 Layout may change whether connected or not.

### Home screen



- (A) Menu bar
- (B) Connection tab

- (C) File tabs
- (D) Tool bar
- (E) Main content header
- (F) Main content
- (G) Filter parameters box
- (H) Primary navigation side bar
- (I) Tab context

### Secondary navigation side bar

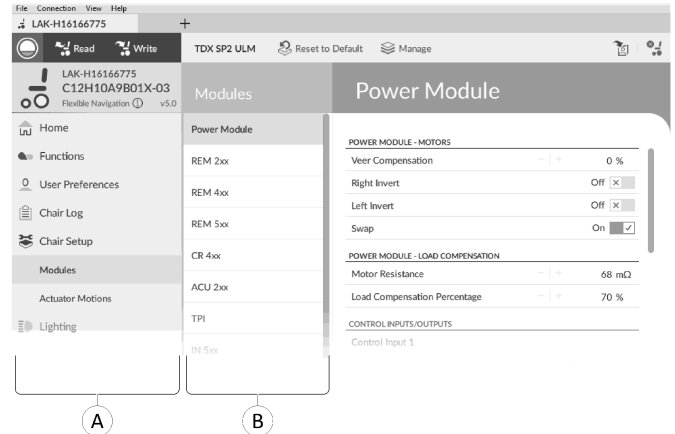

The secondary navigation bar (B) is only displayed for certain primary navigation bar selections (A) and provides a means to drill down further through the features, functions and parameters.

### Opening

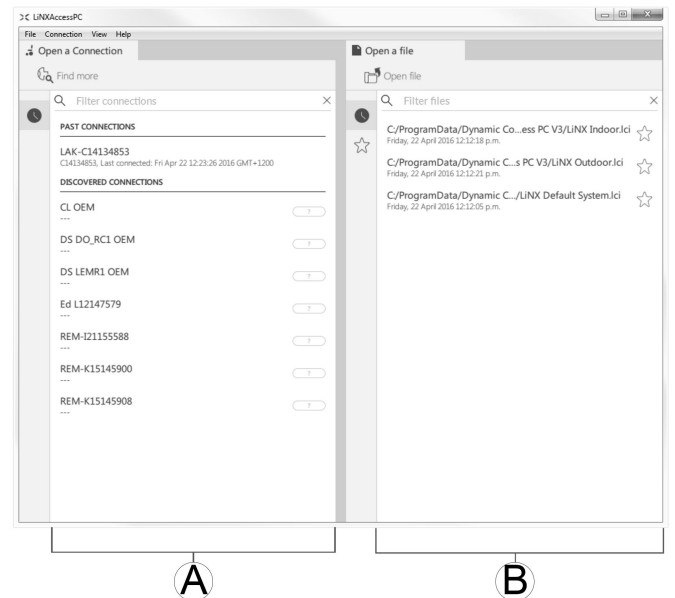

- (A) Open a connection
- (B) Open a file

## System information

A	Driving / battery information	Displays time statistics for driving and battery use.
B	Events	Displays overview of events.
C	File information	Displays time stamps for when the configuration was created and last modified.
D	System name and program name	Displays the system and program name.
E	Configuration summary	Overview of modules, features and functions for the connected system.
F	System summary	Click to view version information about the modules in the connected system.
G	LiNX Access information	Displays LiNX Access Key and application details.

## 9.3 Concepts

The LiNX Access PC tool provides many tools and features to simplify configuring and programming LiNX modules and systems.

Two important concepts are:

- context modes
- editing modes

## Context modes

The context modes allow you to work with configuration files both online (that is with a connected system) and offline (that is with files stored on your computer) simultaneously. There are two context modes:

- **Connection context** (A). The PC tool interacts with a connected system. From the Open a connection tab, you can connect to a wheelchair through a LiNX Access Key.
- **File context** (B). The PC tool interacts with stored files on your computer. From the Open a file tab, you can access a file stored on your computer.

 The connection tab is always found on the left side of the application's screen. You can only have one connection tab open at any time.

File tabs are always placed to the right of the application's screen. The application allows multiple file tabs to be open at any time.

### Editing modes

The LiNX Access PC tool offers two parameter editing modes that define when parameters are written to the wheelchair. These modes are:

- **Live edit** (connection context only).
- **Bulk edit**.

For more information about the editing modes, refer to *7.3.5 Modifying a Program, page 63*.

## 9.4 Checking and getting the latest version

The LiNX Access PC tool automatically checks for updated software and firmware. This operation requires an Internet connection and is only performed in a 24 hour period. If application updates are available, a notification is displayed asking if you want to download the updates. Click on **Yes** button to continue. After the application updates have been downloaded, a notification is displayed, asking if you want to install the updates. Click on **Yes** button to continue.

To manually check for updates, you can either:

- check the Dynamic Controls website at [www.dynamiccontrols.com](http://www.dynamiccontrols.com) or

- from the main menu on the LiNX Access PC tool, click on **Help** and then on **Check for updates**.

To view which version you have installed, click on **Help** on the menu bar and then click on **About**.

 An Internet connection is required when checking for updates. If an Internet connection is unavailable, the following message is displayed:

Failed to check for updates. The software was unable to connect to the Internet. Check that your network settings are correct and try again.

If your computer uses a proxy server to connect to the Internet, then you need to configure your Internet settings.

### Configuring Internet settings

1. Click on **Help** and select **Internet Settings**.
- 2.

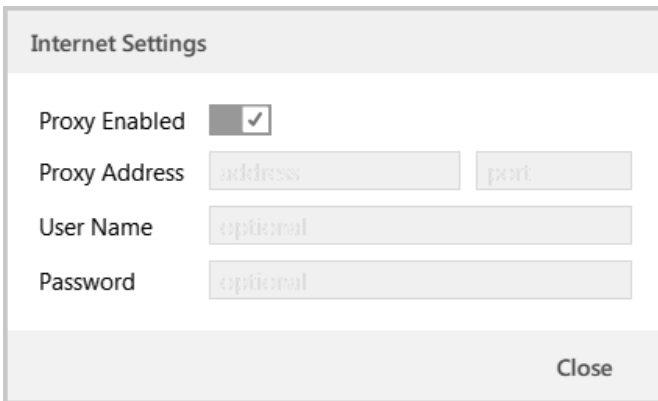

Enable proxy settings by clicking on **Proxy Enabled** switch.

3. Add following details (you may need to consult your IT department for this information):
  - **Proxy address and port**
  - **User name**
  - **Password**
4. Click on **Close** button.

## 9.5 Connection context actions



The following tasks are only relevant for the **Connection context** mode. For tasks related to the **File context** mode, refer to *7.4 File context actions, page 66*.

### 9.5.1 Connecting/Disconnecting the LiNX Access PC tool

#### Connecting to a wheelchair

1. Power up LiNX system.
2. Insert LiNX Access Key into remote module.

3. Open LiNX Access PC tool application.
4. From the **Open a connection** tab:
  - a. Select LiNX Access Key from list under **PAST CONNECTIONS**, or
  - b. click **Find more** button (top left) to force application to search for more LiNX Access Keys, or
  - c. if list is too long to read, enter LiNX Access Key into **Filter connections** text box to locate LiNX Access Key in list.

After selecting a LiNX Access Key, the LiNX Access PC tool connects to the wheelchair and reads its configurations.

#### Disconnecting from a wheelchair



To disconnect from a connected wheelchair, click the **Disconnect** icon on the right-hand side of the tool bar.

### 9.5.2 Write a program to a wheelchair

There is no need to write a program to a wheelchair if you are in connection context and working in live edit mode, because all parameter changes are written to the wheelchair instantly.



If you are working in bulk edit mode, you can write to the wheelchair by clicking on the **Write** button in the tool bar.

After clicking **Write**, the LiNX Access PC tool will perform the following tasks:

- Write the program to wheelchair.
- Power cycle wheelchair.
- Read program from wheelchair.
- Read diagnostic information from wheelchair.

After the Write operation, the LiNX Access PC tool reverts to live edit mode.

### 9.5.3 Read a program from a wheelchair

The configuration program is automatically read from a wheelchair system when you connect to it. However, you can manually read the configuration program from the connected wheelchair by placing the LiNX Access PC tool in bulk edit mode or file context mode.

#### To read configuration from bulk edit mode

1. Change to bulk edit mode by unlocking bulk edit parameter.
- 2.



Click on **Read** (from wheelchair) icon in tool bar.

#### To read a configuration from file context

1. Open file by clicking on **New file** tab (+) and selecting existing file.
2. Click on **Read** (from wheelchair) icon in tool bar.



## 9.5.4 Save a program as a file

1.

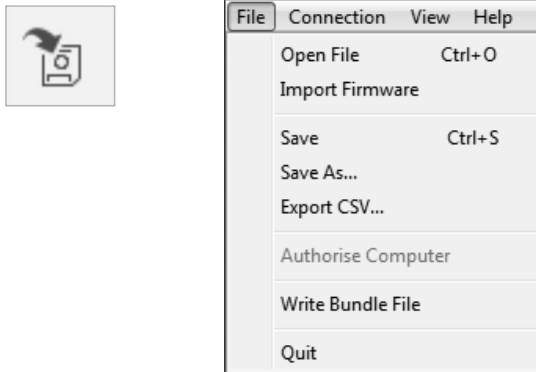

Click on **Save to file** button or click on **File** in menu bar and select either **Save** or **Save As...** from menu.

2. **Save File As** dialogue opens.
3. Select appropriate folder.
4. Enter name into **File name** box.
5. Click on **Save** button to finish. The file is saved with .lci extension.

### Remove a file from the file list

1.

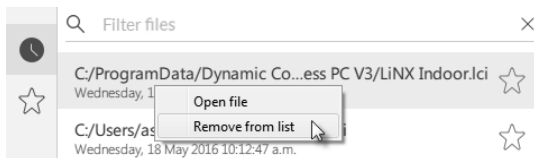

Right-click on file in **Open file** dialogue and select **Remove from list**.

## 9.5.5 Storing the LAK certificate

To edit files offline, you need to authorize your computer by storing the LiNX Access Key (LAK) certificate.

The LAK certificate determines how you view and edit offline programs (.lci files) and is taken from a connected LiNX Access Key to provide one of two levels of access, that are:

- Distributor and
- Read-only.

To edit your files with a Distributor's access level, you need to store an LAK certificate from a LiNX Access Key.

If you do not store you LAK certificate from your LiNX Access Key, you have read-only access to your stored files and therefore you are not able to edit them.

To store LAK certificate:

1. Connect to LiNX system.
2. Click on **File** menu.
- 3.

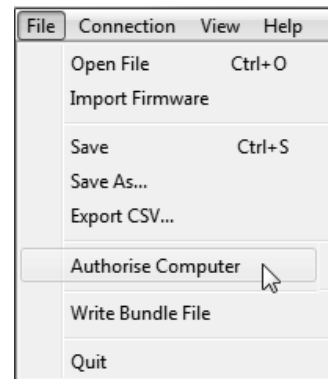

Select **Authorise Computer** option. A message is displayed telling you how many authorizations remain (you can only perform this operation three times) and asks if you want to continue.

4. Click on **Authorise** button to continue.
5. A message is displayed when the authorization is complete. Click on **OK** button to finish.

## 9.5.6 Upgrading Firmware

## 9.5.7 Restoring Default Wheelchair Configurations

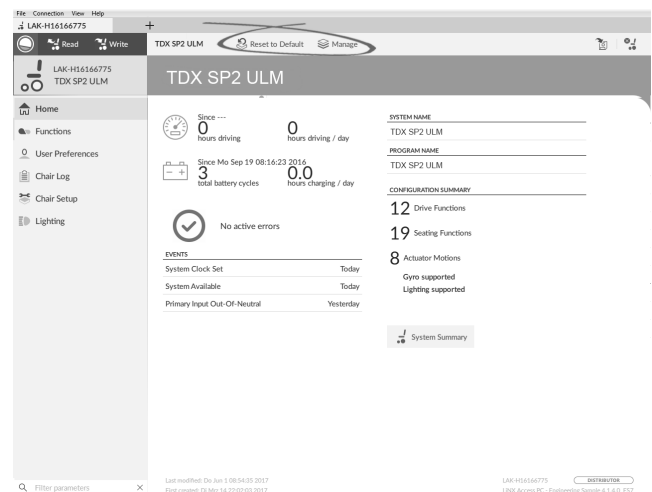

Fig. 9-1

### Loading stored Wheelchair Configurations



1. Click **Manage** to open wheelchair configuration list.
- 2.

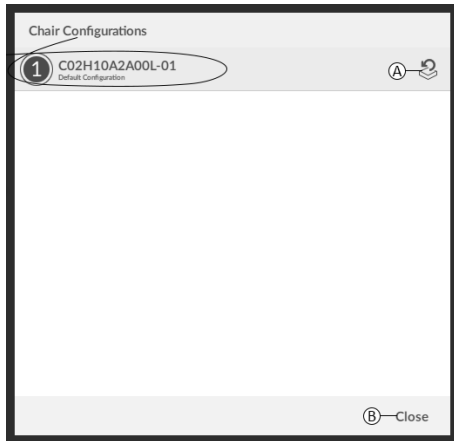

Fig. 9-2

Click on icon (A) behind desired wheelchair configuration.

- 3.

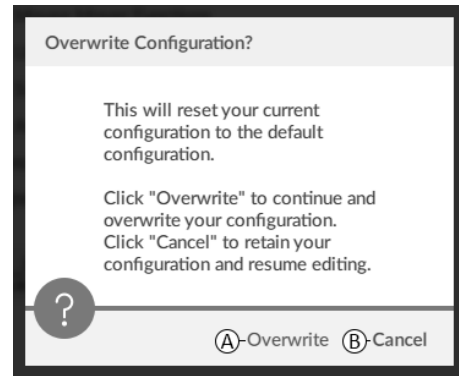
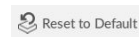

Fig. 9-3

A message is displayed warning you, that current configuration will be overwritten. Click **Overwrite** (A) to finish operation. Otherwise, click **Cancel** (B) to abort operation.

### Loading Default Wheelchair Configuration



To reset the connected wheelchair configuration to the selected default wheelchair configuration:

1. Click on **Reset to Default** button on the tool bar.
- 2.

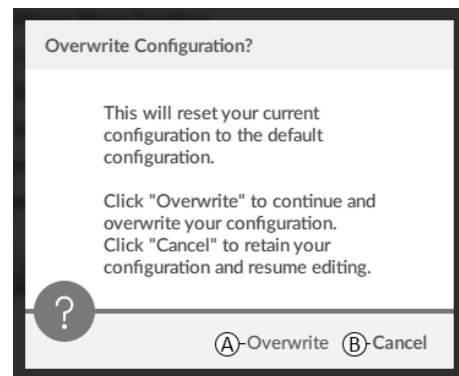

Fig. 9-4

A message is displayed warning you, that current configuration will be overwritten. Click **Overwrite** (A) to finish operation. Otherwise, click **Cancel** (B) to abort operation.

**i** Default chair configuration means last connected configuration.

If chair configurations are not supported by wheelchair, such as in LiNX LE systems, **Reset to Default** and **Manage** are not displayed.

### 9.5.8 Loading Default Configurations

1. Open LiNX Access tool.
- 2.

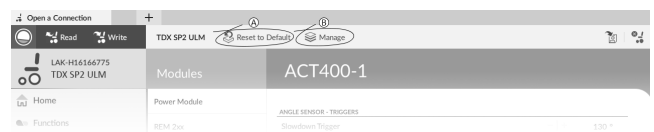

Fig. 9-5

Click either on button **Reset To Default** (A) or **Manage** (B) in tool bar.

3.

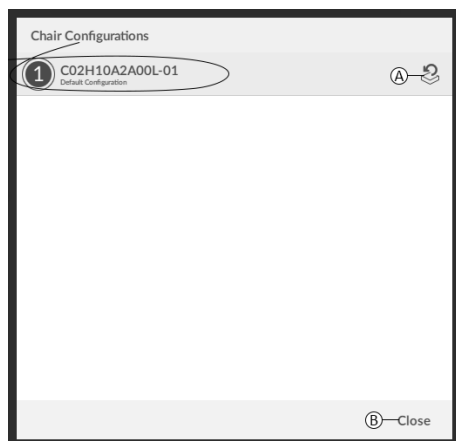

Fig. 9-6

If chosen **Manage**, you will see a list with default configurations stored on power module. Click on icon **A** behind the preferred configuration. Otherwise, click button **B** to abort.

4.

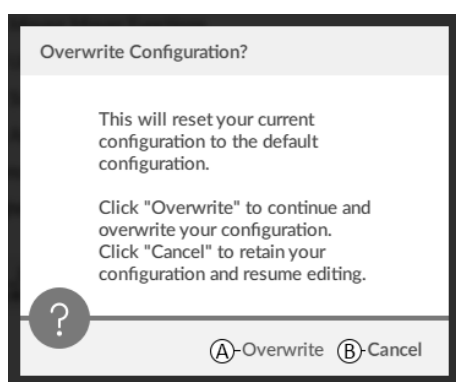



Fig. 9-7

A message box appears. Confirm the reset by clicking on button **Overwrite** (**A**). Otherwise, click on button **Cancel** (**B**) to abort.

5. Modify parameters, especially lighting functions (see [10.3.1 Modifying Lighting Parameters, page 94](#)) and gyro status (see [10.3.2 Modifying Gyro Support in Drive Functions, page 95](#)).

### 9.5.9 Converting Configuration Files

Using older configuration files on wheelchairs can result in missing features which were introduced in later revisions of firmware, such as Switch Control. In most cases, converting these configuration files allows you to update user's configuration to latest release to enable all features.

 In case configuration file is on current revision or incompatible, menu entry is shown greyed out.

1. Connect with wheelchair.
2. Click on **File** in menu bar.
- 3.

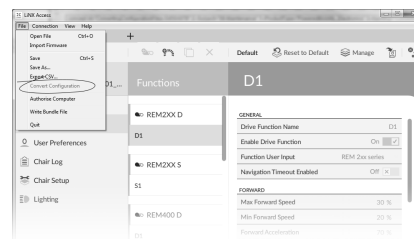

Fig. 9-8

Select entry **Convert Configuration** and follow screen prompts.

## 9.6 File context actions



The following tasks are only relevant when in the **File context** mode. For tasks related to the **Connection context** mode, refer to [9.5 Connection context actions, page 88](#).

### 9.6.1 Open/Close a file

**If the LiNX Access PC tool is not open**

1. Open LiNX Access PC tool.
2. From **Open a file** tab:
  - a. select file from list, or
  - b. click **Open file** button (top left) to open the **Open file** dialogue, or
  - c. if list is too long to read, enter file name into **Filter files** text box to locate file in list.
3. Select file.

**If the LiNX Access PC tool is already open**

1. Click on **New file** tab (+).
2. From this tab:
  - a. select file from list, or
  - b. click **Open file** button (top left) to open the **Open file** dialogue, or
  - c. enter file name into **Filter files** text box to locate file in list.
3. Select file.

**Open via File menu**

1. Click on **File** menu.
2. Select **Open file** to open the **Open file** dialogue.
3. Select file.

After selecting a file, the LiNX Access PC tool opens the file under its own tab. The tab is named with the file name.

**Close a file**



Close a file using the **Close file** button, located on the right-hand side of the tool bar. If you attempt to close a file with changes pending, a dialogue opens with the options to:

- **Save** — save the changes before closing

- **Discard** — discard the changes and close the file
- **Cancel** — cancel the file close action

For information about modifying parameters, refer to *10 Modifying wheelchair configuration with PC tool, page 93*. For information about saving files, refer to *9.5.4 Save a program as a file, page 89*. For information about reading a program, refer to *9.5.3 Read a program from a wheelchair, page 88* and for information about writing a program to a wheelchair, refer to *9.5.2 Write a program to a wheelchair, page 88*.

### 9.6.2 Remove a file from list

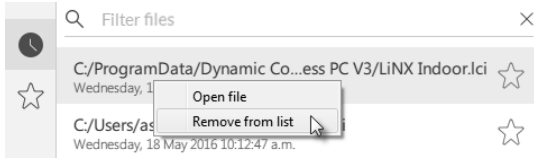

Right-click on a file in the open file dialogue and select **Remove from list**.

### 9.6.3 Writing bundle files to a chair

Bundle files can be written to a connected chair. Bundle files can include wheelchair configurations and/or firmware files.

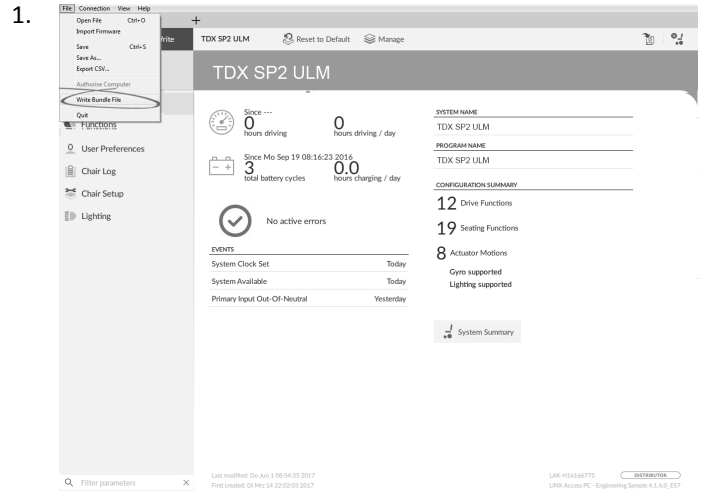

Click on **File** menu.  
Select **Write Bundle File**.

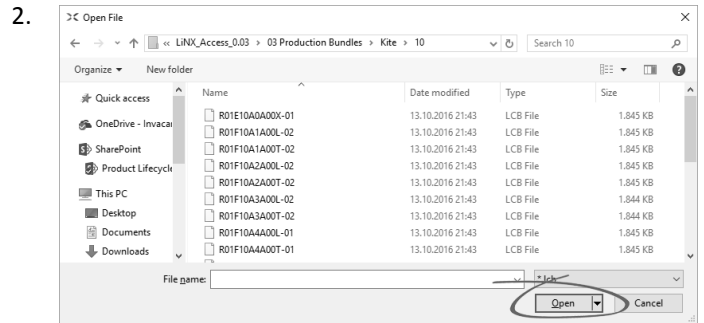

Select desired bundle file and click **Open**.

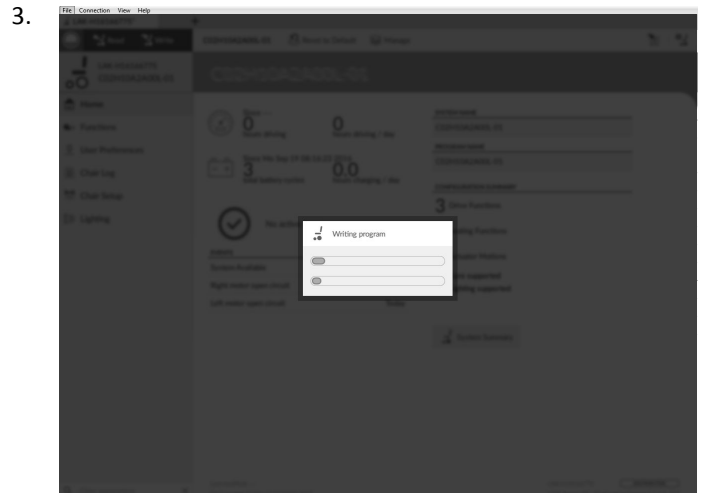

Bundle file is written to chair.

# 10 Modifying wheelchair configuration with PC tool

## 10.1 Profile and Function Actions

In bulk edit mode:

- profiles can be added and deleted,
- functions can be added, deleted, duplicated and moved.

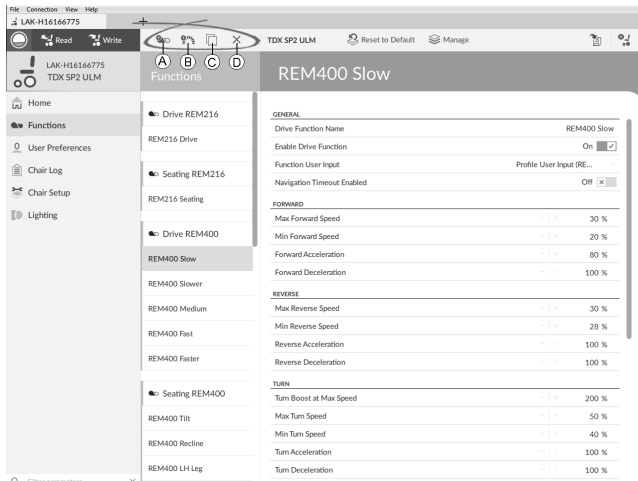



Fig. 10-1

- (A) New Profile
- (B) New Function
- (C) Duplicate Function
- (D) Delete Profile or Function

**i** A system always includes a REM2xx Drive Function profile and a REM2xx Seating Function profile. These cannot be moved or deleted.

1. Open **Functions**.
2. Select desired profile or function action in the toolbar.

### Add new Profile

1.  Click on icon (A).  
New profile is displayed in **Functions**.
2. Change name of profile, see *10.2 Modifying function and profile names, page 94*.
3. Add at least one function. See *Add User Function, page 93*.

**i** New profile is displayed as invalid as long as no function is added to the profile.

### Add User Function

**i** When creating a new function all parameters will be set to their default values and will require modification. It might be easier to duplicate an already existing function and move it to current profile.

1. 
2. Click on icon (B).

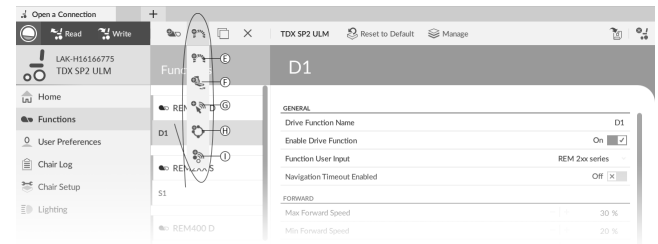

Fig. 10-2

Icon	Action
(E)	Add new drive function
(F)	Add new seating function
(G)	Add new mouse mover function
(H)	Add new utility function
(I)	Add new switch control function

Click on icon to add desired function. Dialog box is displayed.

- 3.

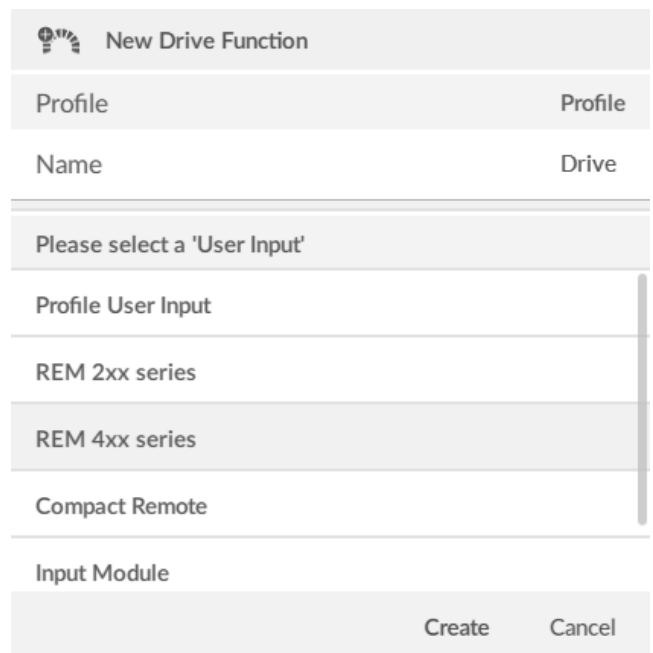

Fig. 10-3

4. Enter a function name.
5. Select **User Input** from list.
6. Click **Create** to proceed. Otherwise, click **Cancel**.

For more information about modifying drive parameters, see *10.3 Modifying drive parameters, page 94*.

For more information about modifying seating parameters, see *10.5 Modifying Seating Parameters, page 95*.

For more information about setting up mouse mover, see user manual of remote.

### Duplicate Function

1. Select function you want to duplicate.
- 2.



Click on icon ©. duplicated function appears directly under original function.

3. Edit function as required.

### Move Function

Functions can be reordered by dragging and dropping inside a profile or between profiles.

- 1.

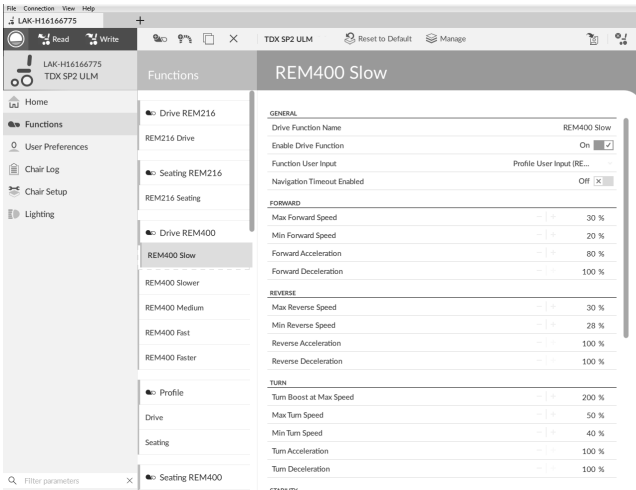

Fig. 10-4

Click and hold function you want to move. Function moves slightly up and to the right and a dashed box appears beneath it.

2. Drag function to required position in same or another profile.

### Delete Function of Profile

- 1. A function is deleted immediately when the delete button is clicked.
- 2. A profile cannot be deleted until its functions are deleted.

1. Select function or profile you want to delete.
- 2.



Click on icon ©.

## 10.2 Modifying function and profile names

- 1. Only changing **Drive Function Name** displayed. Changing **Seating Function Name**, **Mouse Mover Function Name** or **Profile Name** works the same way.

- 1.

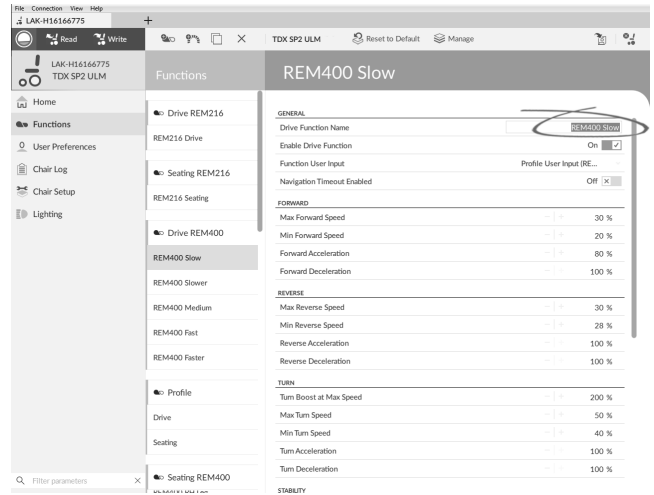

Click on function name.

2. Enter new function name.

## 10.3 Modifying drive parameters

1. Select a parameter to edit.
2. Click on the parameter's name to open the parameter's details. Default, minimum and maximum values will be displayed, as well as the parameter's summary.
3. There are different ways to modify the parameters:

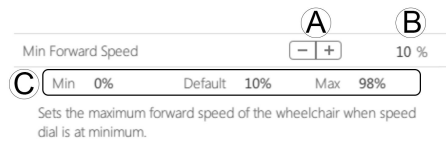

- a. Increment and decrement the parameter with the plus (+) and minus (-) buttons (A). Click these buttons to change the value in discrete steps or click and hold the buttons to change the value more quickly.
- b. Double-click on the value (B) and change it directly via the keyboard — press **Enter** to set the value.
- c. Set the parameter value by clicking on the **Min**, **Default** or **Max** buttons (C).

When you edit a parameter's value, its background color will change to indicate that it has changed from its previous value. Once the value is written to the controller (or file), the background will revert to white.

When in live edit mode, it might be difficult to see the parameter background changing since the live edit operation can take place very rapidly.

### Drop-down list



Click on the drop-down list to select an option.

### 10.3.1 Modifying Lighting Parameters

When installing lighting system, replacing power module or resetting default configuration from power module it can be necessary to adjust lighting settings. In some configurations lighting functions are disabled by default and need manual activation.

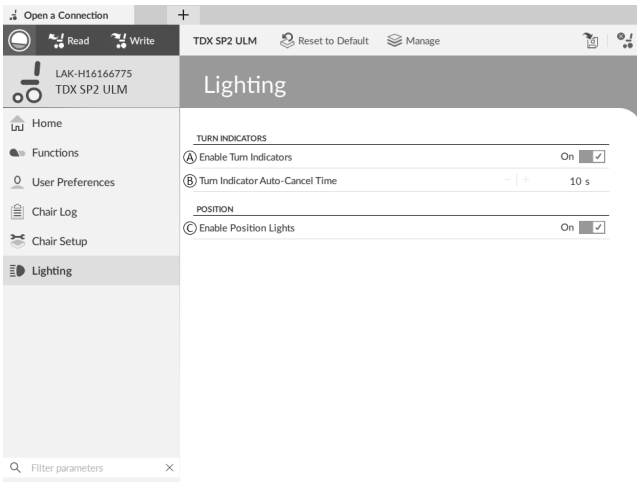

Fig. 10-5

1. If necessary, reset wheelchair configuration. See 9.5.8 *Loading Default Configurations, page 90.*
2. Open **Lighting**.
3. Edit parameters according following table.

	Parameter	Description	Values
Ⓐ	Enable Turn Indicators	Allows system to use turn indicators	Off / On
Ⓑ	Turn Indicator Auto-Cancel Time	Sets length of time a turn indicator will be on before being automatically turned off	0 s ... 30 s
Ⓒ	Enable Position Lights	Allows system to use position lights	Off / On

### 10.3.2 Modifying Gyro Support in Drive Functions

By default, Gyro support is enabled in drive functions. The following instructions show you how to disable the Gyro support for drive functions or to hide Gyro symbol on screen if no Gyro is installed on wheelchair.

1. Open **Functions** → open desired drive function.
- 2.

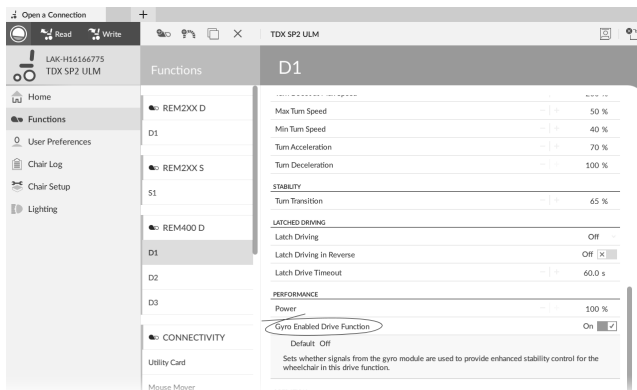

Fig. 10-6

Set **Gyro Enabled Drive Function** to **On**, to provide enhanced stability control for this drive function. Otherwise, set to **Off** to disable gyro support for this function.

## 10.4 Programming Toggle Switches

- Toggle switches are programmable as control inputs.
- Left Toggle Forward and Right Toggle are reserved to their default actions (see user manual of DLX-REM400). It is not possible to change these settings.

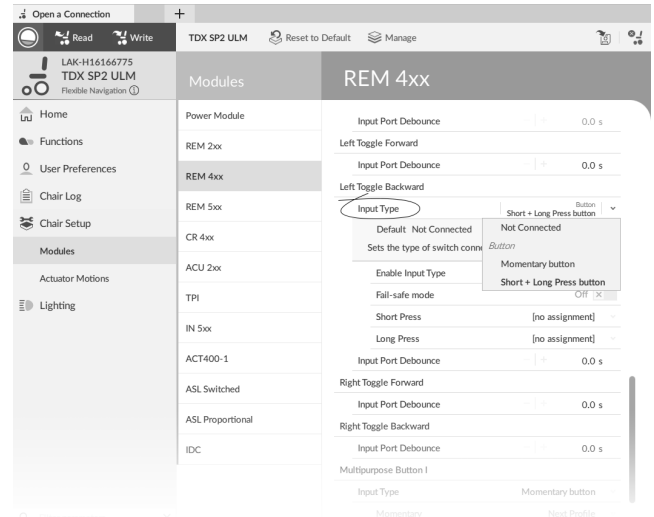

Fig. 10-7

1. Open **Chair Setup** → **Modules** → **REM 4xx**.
2. Set Input Type of input **Left Toggle Backward** to desired value.  
Options are:
  - **Not Connected**
  - **Momentary button**
  - **Short + Long Press button**
3. Assign desired action to **Short Press** and **Long Press**, or **Momentary**.

- For information about the other parameters such as Input Port Debounce, see 10.11 *Programming external switches, page 102*

## 10.5 Modifying Seating Parameters

### Trigger Angles

Angle sensor-triggers allow you to modify factory default angle triggers of wheelchair to accommodate specific user needs.

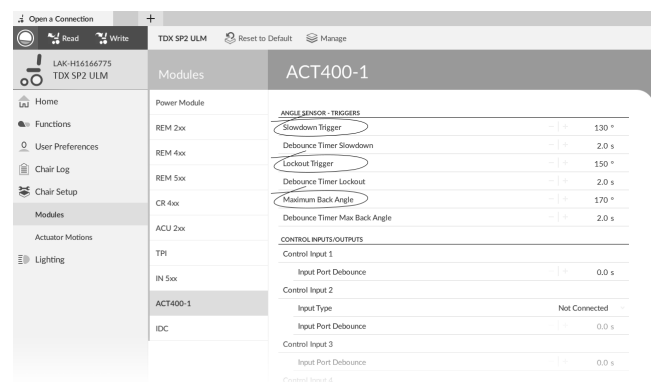

Fig. 10-8

Parameter	Description
<b>Slowdown Trigger</b>	Sets the angle sensor's trigger angle to slow down the driving speed
<b>Lockout Trigger</b>	Sets the angle sensor's trigger angle to lock out drive
<b>Maximum Back Angle</b>	Sets the angle sensor's trigger angle to stop further movement of the backrest.

1. Open **Chair Setup** → **Modules**. Select your type of actuator module, for example ACT400-1.
2. Set parameters to user's needs.

**Seating Motion**

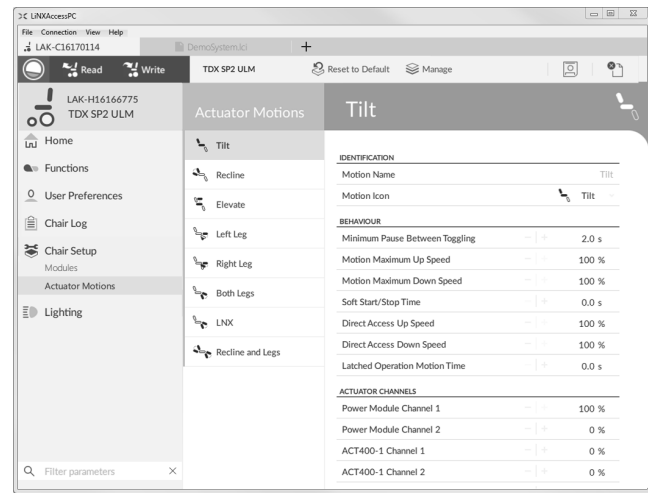

Fig. 10-9

1. Open **Chair Setup** → **Actuator Motions** → select seating motion you want to change.

**Changing Motion Name**

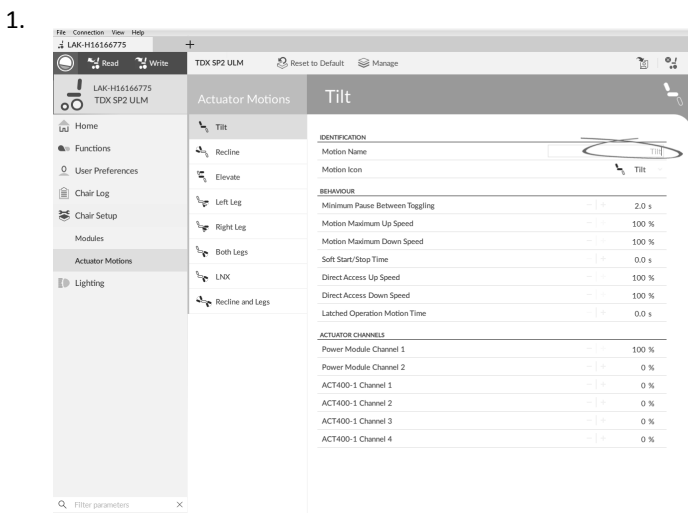

Fig. 10-10

1. Click on **Motion Name**.
2. Enter new motion name.

**Seating Function**

This parameter sets how the joystick operates a motion. The joystick can control the motion as a switch or as a proportional controller. There are four switch-type modes and one proportional-type mode.

1.

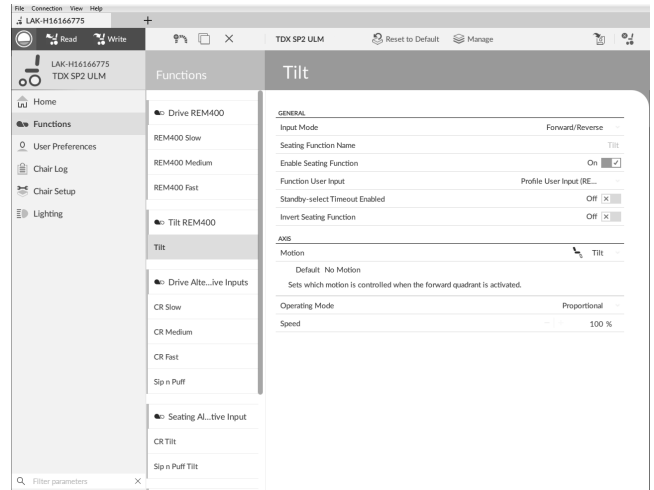

Fig. 10-11

1. Click on **Functions**.
2. Click on seating function you want to edit.

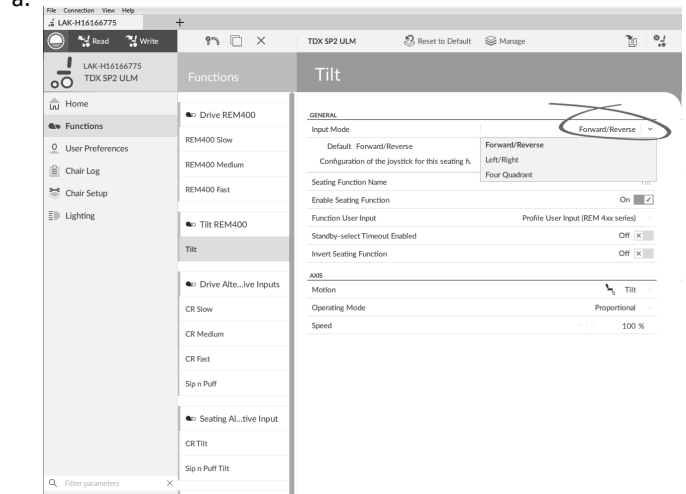
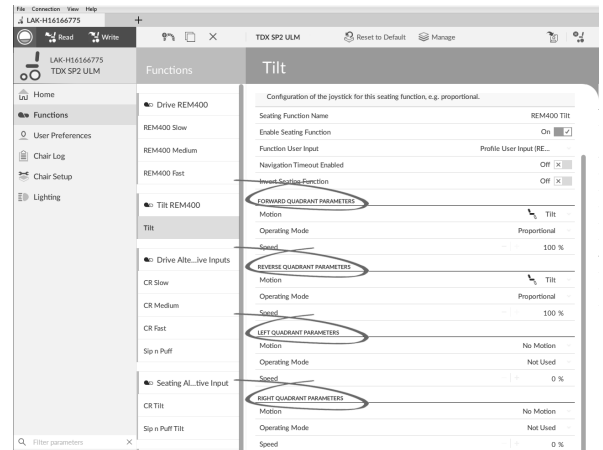

Fig. 10-12

**Input Mode:** Configuration of user input for this seating function.

- **Forward/Reverse:** Moving joystick forward or reverse to control motion.
- **Left/Right:** Moving joystick left or right to control motion.
- **Four Quadrant:** Using all four joystick quadrants to control motions.



If **Four Quadrant** is selected, all quadrant parameters can be edited individually.

b.



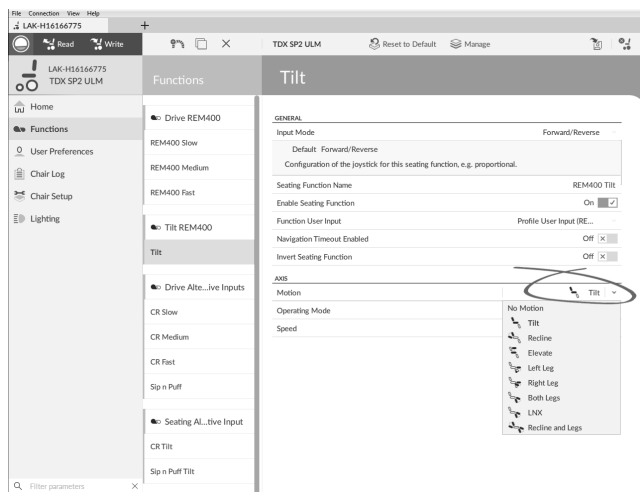
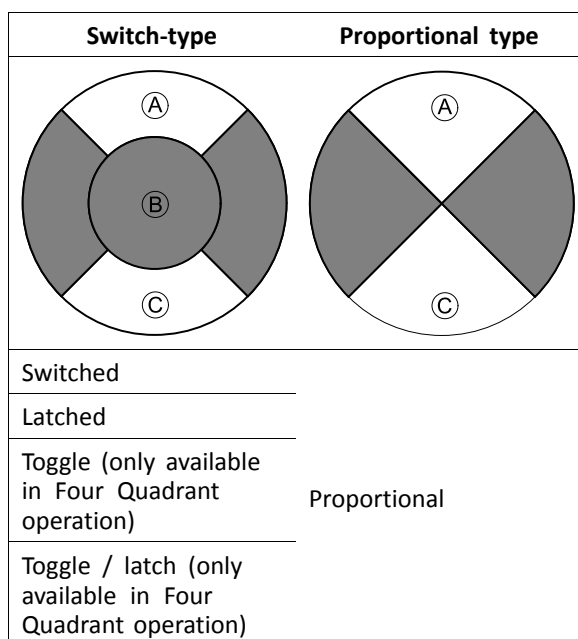

Fig. 10-13

**Motion:** If the joystick is used to control a motion, then select the motion from the list of available motions.  
 If the joystick is not used to control a motion, then select **No Motion** from the list.

c. **Operating Mode:**



Choose one of the switch-type modes to operate the motion at a fixed speed. The motion is activated when the joystick is deflected past the **Joystick Switch Threshold** **B** into either the forward **A** or backward **C** quadrants. See 8.10 *Joystick Switch Threshold*, page 77 how to modify the **Joystick Switch Threshold**.

Choose the proportional-type mode to operate the motion at a speed that is proportional to the joystick's position. The motion is activated when the joystick is deflected out of neutral into either the forward **A** or backward **C** quadrants.  
 If the joystick is not used to control this motion, then set this parameter to Not Used.

Operation	Purpose
Switched	Activates the motion in the extend / retract direction for the duration that the joystick is deflected forwards / backwards and its position is greater than Joystick Switch Threshold. The motion is deactivated when it reaches its end-of-travel or when the joystick's position is less than the Joystick Switch Threshold.
Latched	Activates and latches the motion in the extend /retract direction when the joystick is momentarily deflected forwards / backwards across the Joystick Switch Threshold. The motion is deactivated when the motion reaches its end-of-travel or the joystick is deflected again across the Joystick Switch Threshold.
Toggle	Activates the motion in one direction (extend or retract) for the duration that the joystick's position is greater than Joystick Switch Threshold. The motion is deactivated when it reaches its end-of-travel or when the joystick's position is less than Joystick Switch Threshold. The direction of the motion toggles between extend and retract for each new activation.
Toggle / latched	Activates and latches the motion in one direction (extend or retract) by momentarily deflecting the joystick across the Joystick Switch Threshold. The motion is deactivated when the motion reached its end-of-travel or the joystick is deflected again across the Joystick Switch Threshold.

Operation	Purpose
Proportional	Deflecting the joystick forwards /backwards activates the motion in the extend / retract direction for the duration that the joystick is deflected. The motion is deactivated when it reaches its end-of-travel or when the joystick is returned to the neutral position. The speed of this motion is controlled by the amount of deflection from the neutral position and scaled further by using the Speed parameter.
Not Used	No operation.

- d. **Speed:** For the switch-type operations (Switched, Latched, Toggle, Toggle / latched), this parameter applies the speed of the motion when the joystick crosses the **Joystick Switch Threshold**. For the proportional operation, this parameter sets the maximum speed at which the motion will travel when the joystick is deflected to 100 % of its travel. For all other positions of joystick deflection the applied speed will be scaled down accordingly.

### 10.6 Modifying Attendant Parameters

Attendant profiles allow an attendant to control drive functions and seating functions of wheelchair. Currently two User Inputs are available, Attendant Control Unit (DLX-ACU200) and Intuitive Dual Control (Invacare IDC).

#### Attendant Control Unit (DLX-ACU200)

Input allows programming drive functions and seating functions. Parameters of functions are identical to primary remotes. See 10.3 *Modifying drive parameters, page 94* and 10.5 *Modifying Seating Parameters, page 95*.

#### Intuitive Dual Control (Invacare IDC)

Input allows programming maximum one drive function.

#### Add New Attendant Function

 Tool allows you to add all function types to Attendant profile. In case of an invalid function, like Switch Control, you will get error prompt with further instructions to solve error.

 When creating a new function all parameters will be set to their default values and will require modification. It might be easier to duplicate an already existing function and move it to current profile.

1. Open **Functions**.
2. Select profile **Attendant** from list. Otherwise, both user inputs are not available.
3. Add new function or duplicate existing function. See 10.1 *Profile and Function Actions, page 93*.
4. Modify other parameters.

### 10.7 Joystick Switch Threshold

Sets the percentage of joystick movement required to activate an output when the joystick is operating as a switched input device.

When the joystick is used as a switched input device, this parameter specifies how far the joystick has to be pushed before its state changes (OFF **B** to ON **A**) and activates an output. The **Joystick Switch Threshold** value is a percentage of the joystick’s full travel and should be set according to the user’s needs. For example:

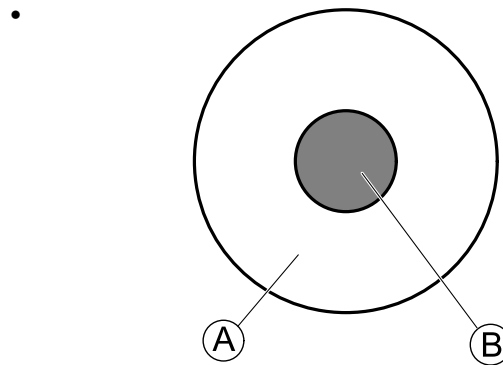

for users that have difficulty moving the joystick , set **Joystick Switch Threshold** to a low value, such as 40 % or less,

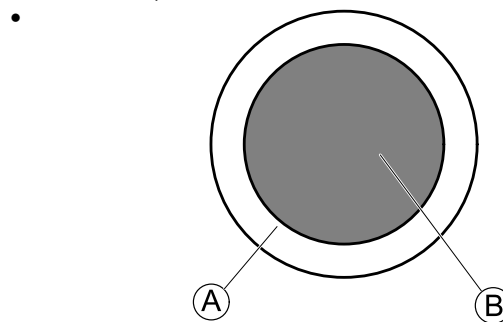

for users that lack fine motor control or are subject to hand tremors, set **Joystick Switch Threshold** to a high value, such as 80 %, to avoid unintentional switching.

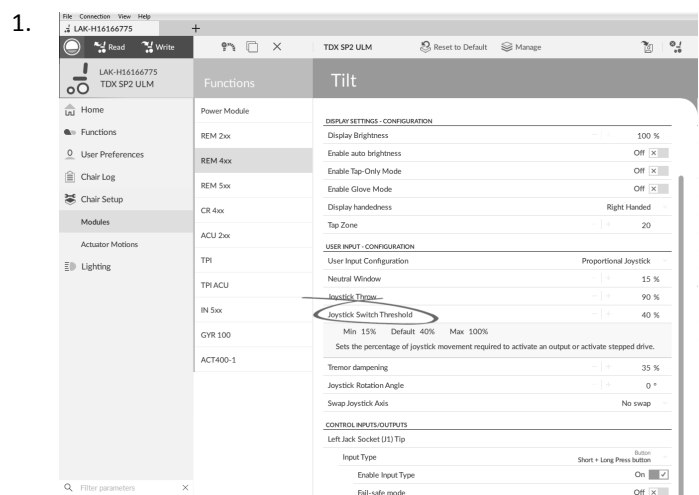

Click on **Chair Setup**.

2. Click on **Modules**.
3. Click on remote you want to edit.
4. Set the desired percentage.

## Tremor dampening

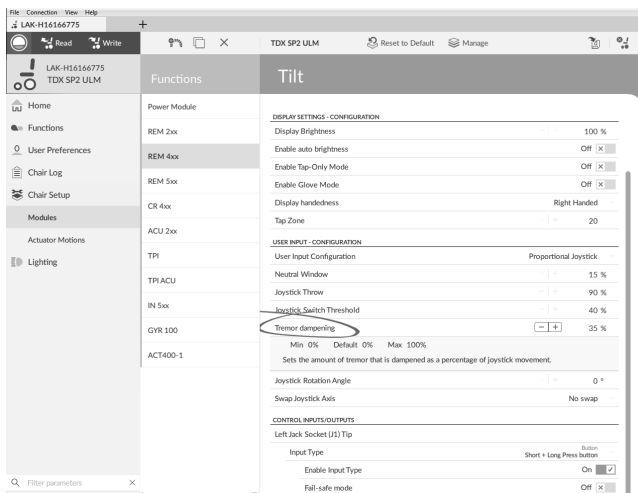

Use this parameter to reduce the effect of hand tremors on the joystick. Low values are suitable for users with low frequency (slow) tremors. Higher values will suit users with higher frequency (fast) tremors. Setting the parameter value to 0 % results in no tremor dampening.

## 10.8 Setting up a system for latched driving

To set up a wheelchair for latched driving, an external stop switch must be fitted to the wheelchair. Ideally, the external stop switch should be highly visible and easily accessible to provide an extra level of safety and security for the user.

Connect the external stop switch to a control input. Invacare recommends to connect the external stop switch to the input module. The external stop switch should be a single pole, normally-open switch. Mostly latched driving is used in combination with a Sip and Puff array, where the lip switch serves as external stop switch.

### Configure external stop switch parameters

Configure following parameters to set up the external stop switch.

1. Open **Chair Setup** → **Modules** → desired input to which external stop switch is connected.

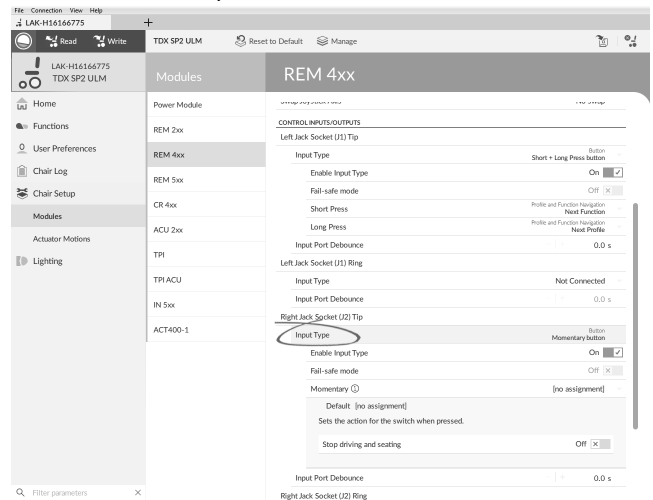

Set **Input Type** to desired input, for example, **Momentary**.

- 3.

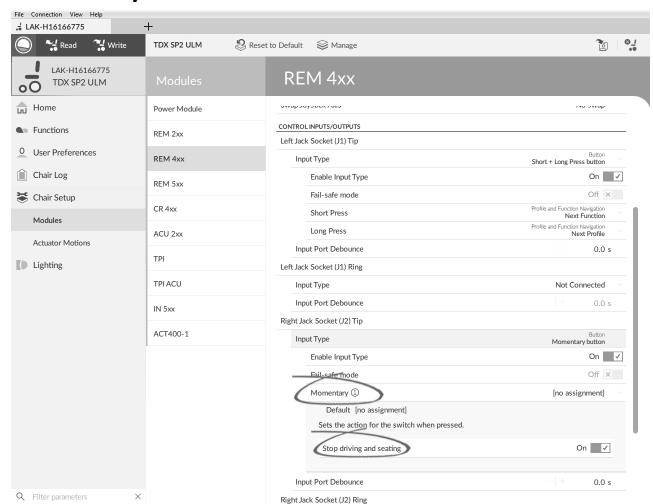

Click on information icon next to **Momentary**. Enable **Stop driving and seating**.



You do not need to assign a function to the switch.

### Configure latch drive parameters

The following parameters can be set individually for each drive function.

1. Open Functions → open desired drive function.
- 2.

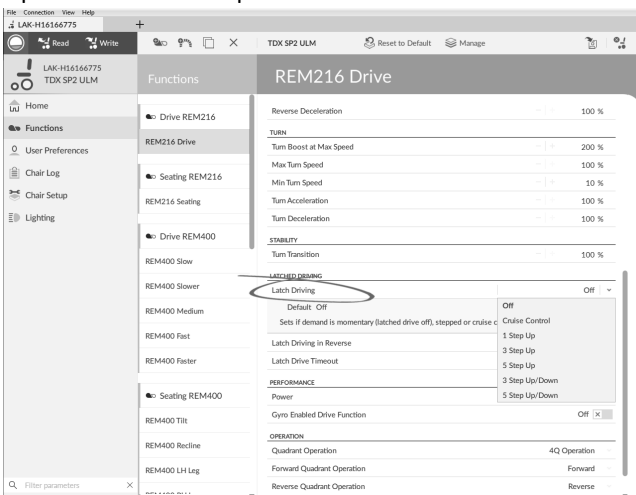

Set type of latched driving with **Latched Driving**. For more information about types of latched driving, refer to user manual of remote.

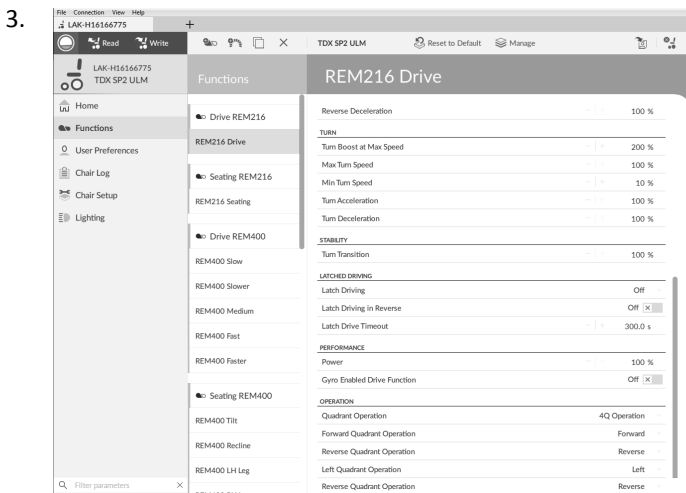

Set **Latched Driving in Reverse** parameter to **On**, to allow latched driving in reverse.

4. Set maximum time that driving is latched without input from user with **Latched Drive Timeout** parameter.

## 10.9 Adjust quadrant operation

This parameter sets the drive function's user input to operate in 3-quadrant (3Q) or 4-quadrant (4Q) mode. Typically, the 4Q mode is chosen with joystick-based inputs or arrays, that provide 4 quadrants, for example, a Sip and Puff array. The 3Q mode is chosen for user inputs that provide 3 quadrants, for example, a head array.

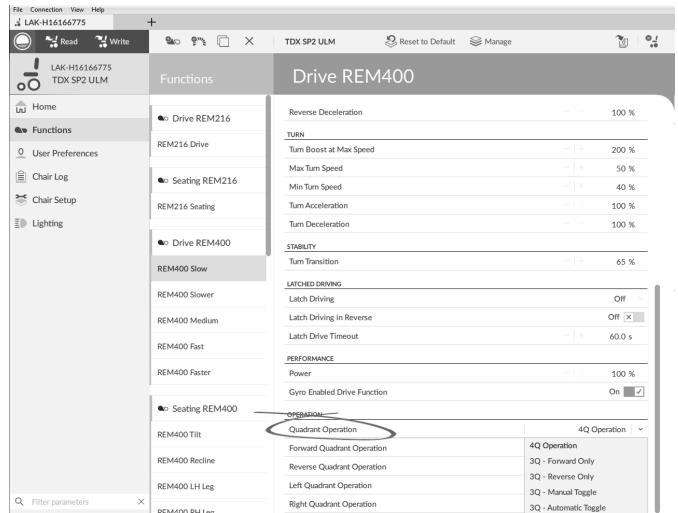

The options are:

- **4Q Operation**
- **3Q - Forward Only**
- **3Q - Reverse Only**
- **3Q - Manual Toggle**
- **3Q - Automatic Toggle**

### 4Q Operation

When **4Q Operation** is selected, each quadrant is assigned a unique direction from forward, reverse, left and right, this is the default mode. To change these default directions, the quadrants can be reassigned with a different direction by setting the following parameters:

- **Forward Quadrant Operation**
- **Reverse Quadrant Operation**
- **Left Quadrant Operation**
- **Right Quadrant Operation**

It is not necessary that all quadrants are assigned unique directions. If required, one or more quadrants can share the same direction. For example, **Forward Quadrant Operation** and **Reverse Quadrant Operation** can both be set to **Forward**. For more information about adjusting the drive direction, refer to *10.9.1 Adjust drive directions, page 101*

### 3Q - Forward Only

When **3Q - Forward Only** is selected, the user input can drive the wheelchair forward, left and right.

If required, each quadrant can be reassigned with a different direction. Note that the **Reverse Quadrant Operation** parameter is not applicable in **3Q - Forward Only** mode.

### 3Q - Reverse Only

When **3Q - Reverse Only** is selected, the user input can drive the wheelchair reverse, left and right.

If required, each quadrant can be reassigned with a different direction. Note that the **Reverse Quadrant Operation** parameter is not applicable in **3Q - Reverse Only** mode.

### 3Q - Manual Toggle

When **3Q - Manual Toggle** is selected, the user input can drive the wheelchair forward, reverse, left and right. The forward and reverse directions are controlled by the user toggling an external switch.

If required, each quadrant can be reassigned with a different direction. Note that the **Reverse Quadrant Operation** parameter is not applicable in **3Q - Manual Toggle** mode.

### 3Q - Automatic Toggle

When **3Q - Automatic Toggle** is selected, the user input can drive the wheelchair forward, reverse, left and right. The forward and reverse directions are controlled by the user toggling the forward quadrant.

If required, each quadrant input can be reassigned with a different direction. Note that the **Reverse Quadrant Operation** parameter is not applicable in **3Q - Automatic Toggle** mode.

## 10.9.1 Adjust drive directions

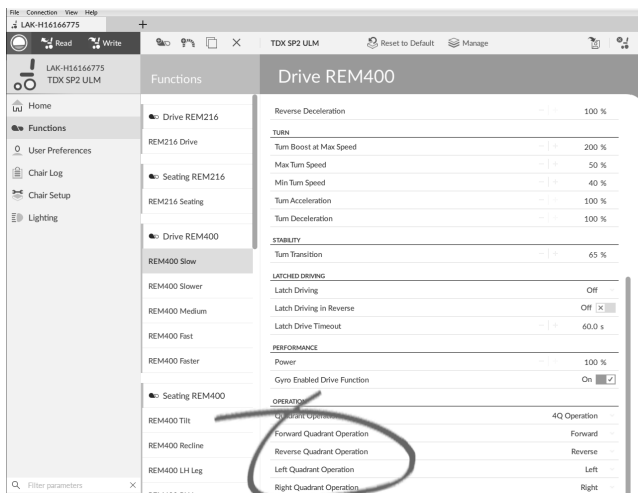

### Forward Quadrant Operation

This parameter sets the direction that the wheelchair moves when the forward quadrant of the user input is selected. Options available are:

- Forward
- Reverse
- Left
- Right
- Ignored

If **Ignored** is selected, the wheelchair does not move in any direction when the input's forward quadrant is selected.

### Reverse Quadrant Operation

This parameter sets the direction that the wheelchair moves when the reverse quadrant of the user input is selected. Options available are:

- Forward
- Reverse
- Left
- Right
- Ignored

If **Ignored** is selected, the wheelchair does not move in any direction when the input's reverse quadrant is selected.

This parameter is not available when quadrant operation is set to any of the 3Q modes.

### Left Quadrant Operation

This parameter sets the direction that the wheelchair moves when the left quadrant of the user input is selected. Options available are:

- Forward
- Reverse
- Left
- Right
- Ignored

If **Ignored** is selected, the wheelchair does not move in any direction when the input's left quadrant is selected.

### Right Quadrant Operation

This parameter sets the direction that the wheelchair moves when the right quadrant of the user input is selected. Options available are:

- Forward
- Reverse
- Left
- Right
- Ignored

If **Ignored** is selected, the wheelchair does not move in any direction when the input's right quadrant is selected.

## 10.10 Enable Indirect Navigation

Depending on which type of indirect navigation should be activated for user, different main parameters must be enabled.

Types of indirect navigation are:

- Menu Select
- Menu Scan

Parameter	Menu Scan	Menu Select
Navigation Type	Menu Scan	Menu Select
Enable Menu Scan	On	Off
Navigation Timeout Enabled	On / Off	On / Off

### Enabling Menu Scan / Menu Select

1. Open **User Preferences**.
- 2.

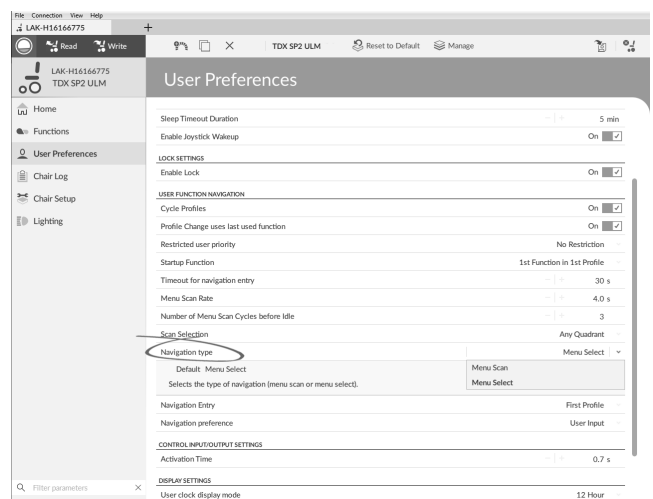

Fig. 10-14

Set parameter **Navigation type** according to above table.

3. Open **Functions** → desired profile.

4.

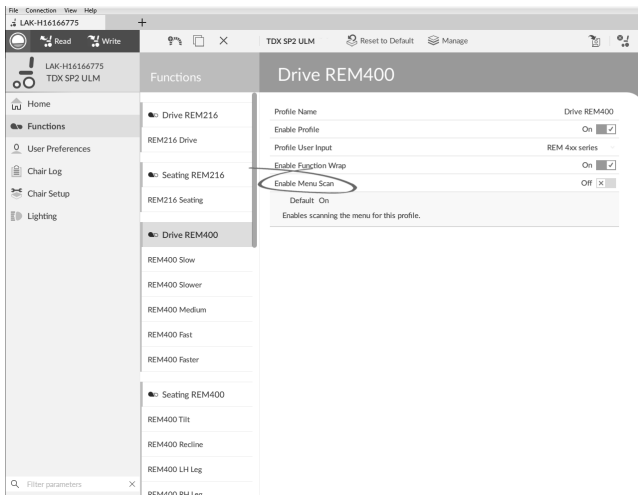

Fig. 10-15

Set Parameter **Enable Menu Scan** according to above table.

5. Open desired function within this profile.

6.

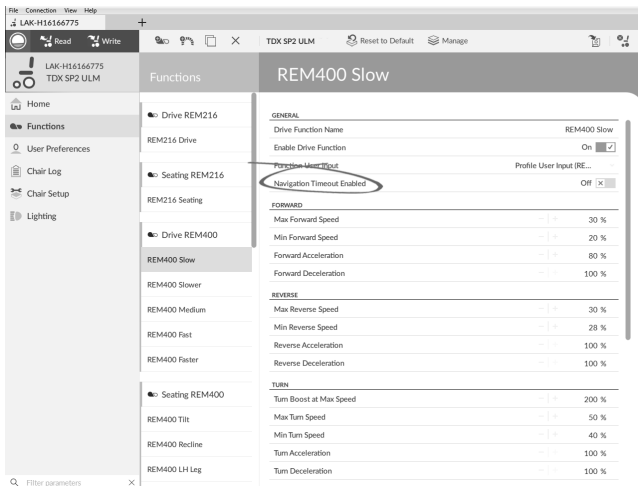
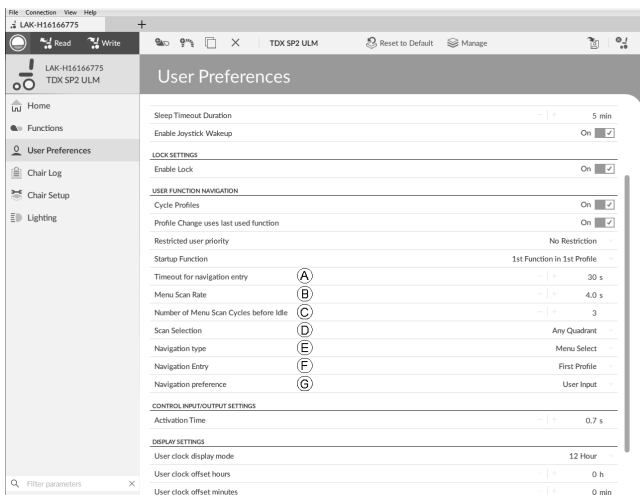

Fig. 10-16

Set parameter **Navigation Timeout Enabled** to Off or On.

7. If **Navigation Timeout Enabled** is set to Off, program an external switch to enter navigation mode. See *10.11 Programming external switches, page 102*

**Other Parameters in User Preferences**



(A)	<b>Timeout for navigation entry:</b> Sets inactivity time required before system enters navigation mode, for navigation mode with <b>Navigation Timeout</b> only.
(B)	<b>Menu Scan Rate:</b> Sets rate at which menu scan iterates through menu, for <b>Menu Scan</b> only.
(C)	<b>Number of Menu Scan Cycles before Idle:</b> Number of times menu is iterated through before going to idle, assuming no user selection, for <b>Menu Scan</b> only.
(D)	<b>Scan Selection:</b> Configures which quadrants of Primary input can be used to make selections, for <b>Menu Scan</b> only.
(E)	<b>Navigation type:</b> Selects type of navigation.
(F)	<b>Navigation Entry:</b> Sets entry point to menu.
(G)	<b>Navigation preference:</b> Selects whether navigation using touch interface has preference over navigation using user input. If user input is selected, display highlights current selection.

**10.11 Programming external switches**

There are a lot of possibilities to connect external switches to the system, for example, jack sockets.



It is exemplary described how to program external switches which are connected to the jack sockets of the DLX-REM400 and DLX-REM500. Left Jack Socket (J1) Tip is reserved to Power Up / Power Down the wheelchair. It is not possible to change this setting.

1. Choose the Input you like to edit, for example **Left Jack Socket (J1) Ring**.

2.

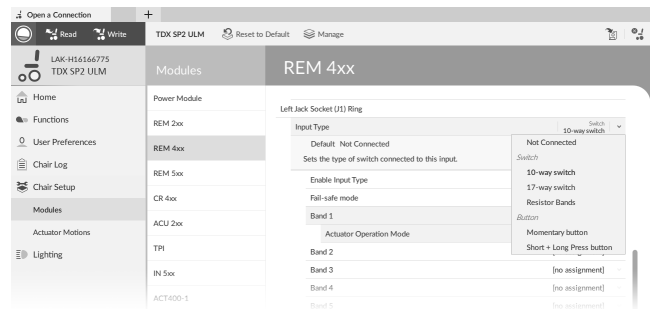

Fig. 10-17

Choose an **Input Type**.

Options are:

- **Not Connected**
- **10-way switch**
- **17-way switch**
- **Resistor Bands** (usable in combination with Function keys)
- **Momentary button**
- **Short + Long Press button**

3.

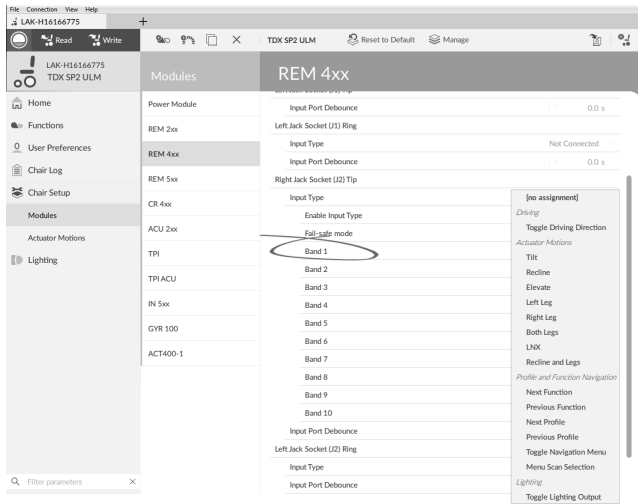

Fig. 10-18

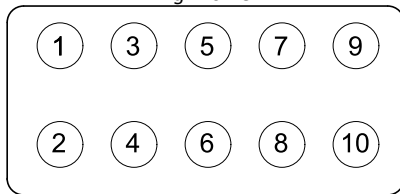

Fig. 10-19 Bands on 10-way-switch

If 10-way switch, Resistor Bands or 17-way switch is selected, assign desired actions to **Band 1** to **Band 10** or **Band 0** to **Band 16**.

a.

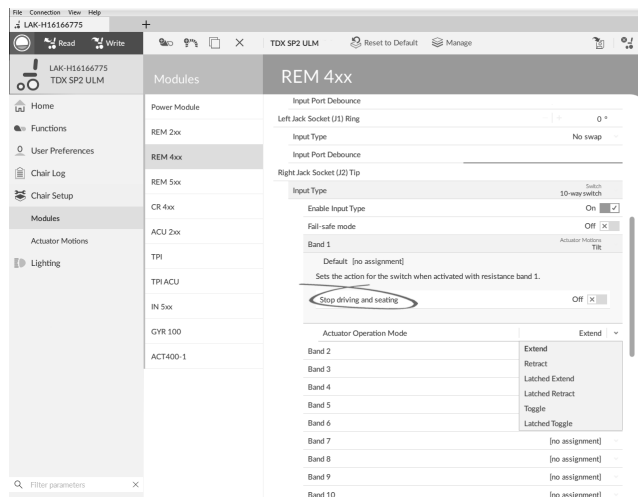

Fig. 10-20

Open parameter by clicking on parameter name.

Select if **Stop driving and seating** should be enabled or not by moving slider. For more information about this parameter, see 10.8 Setting up a system for latched driving, page 99.

b.

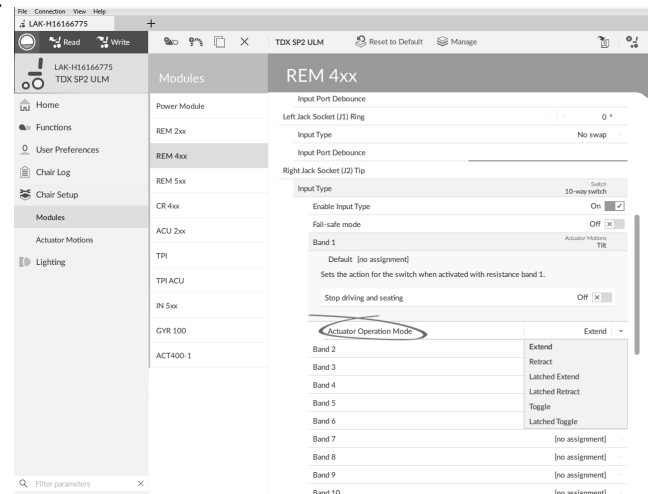

Fig. 10-21

If actuator motion is assigned to parameter, **Actuator Operation Mode** must be selected. The options are:

- **Extend**
- **Retract**
- **Latched Extend**
- **Latched Retract**
- **Toggle**
- **Latched Toggle**

4.

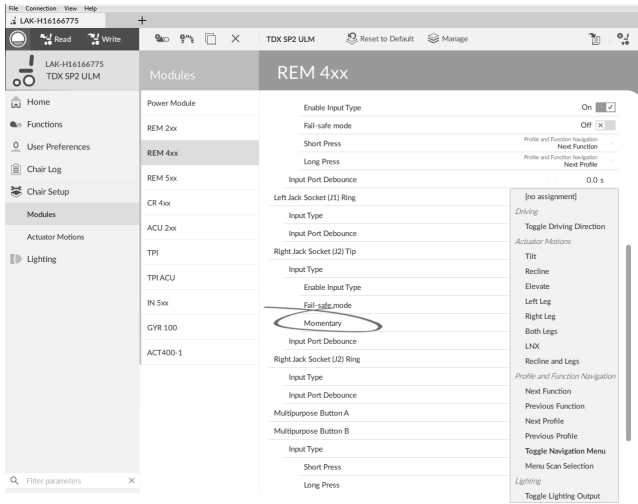

Fig. 10-22

If **Momentary button** is selected, assign desired action to button.

- a. Open parameter by clicking on parameter name. Select if **Stop driving and seating** should be enabled or not by moving slider. For more information about this parameter, see *10.8 Setting up a system for latched driving, page 99*.
- b. If actuator motion is assigned to parameter, **Actuator Operation Mode** must be selected.

5.

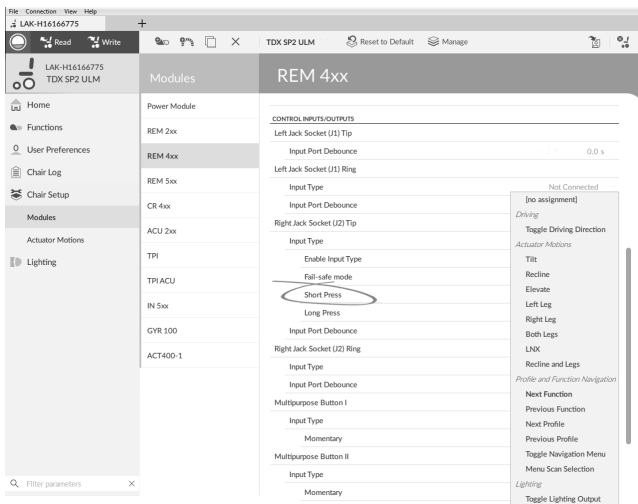

Fig. 10-23

If **Short + Long Press button** is selected, assign desired action to **Short Press** and **Long Press**.

- a. If actuator motion is assigned to parameter, **Actuator Operation Mode** must be selected.



If the external switch should be used to enter indirect navigation, assign **Toggle Navigation Menu** action to parameter.

## Other parameters

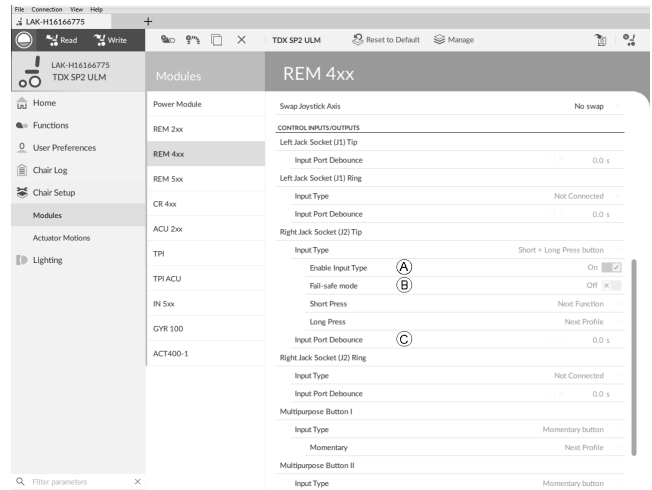

Fig. 10-24

A	<b>Enable Input Type:</b> When set, <b>Input Type</b> is enabled.
B	<b>Fail-safe mode:</b> When turned on, external switch must not be removed from input, otherwise wheelchair does not drive.
C	<b>Input Port Debounce:</b> This parameter determines when to response to input. If input signal is present for a duration less than time set by parameter, controller does not response to it.



**Input Port Debounce** can be useful when, for example, the controller needs to ignore spurious signals such as those generated by a ball switch when driving over rough terrain.

## 10.12 Programming multipurpose buttons

Programming the multipurpose buttons is similar to programming external switches.

1. Open **Chair Setup** -> **Modules** -> **REM 4xx** or **REM 5xx**.

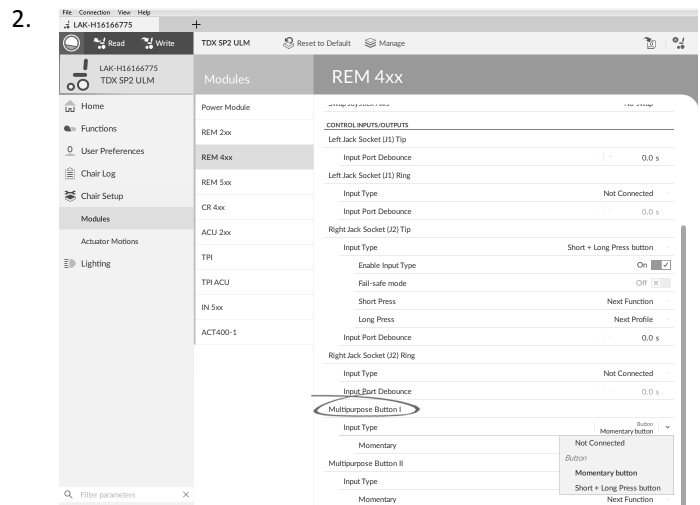

Choose **Input Type**.

The options are:

- **Not Connected**
- **Momentary button**
- **Short + Long Press button**



3.

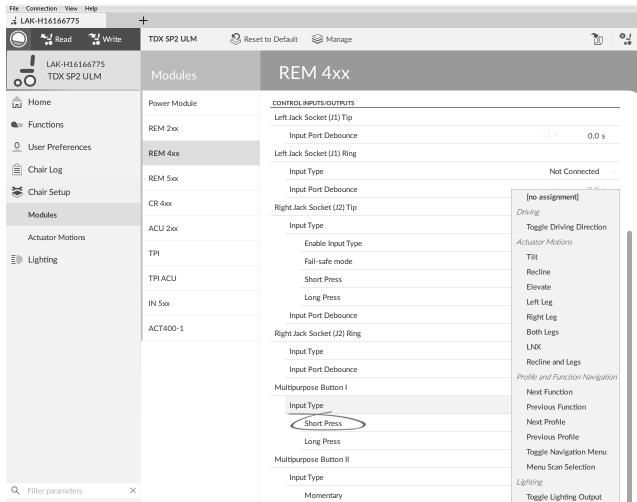

If **Short + Long Press button** is selected, assign desired action to **Short Press** and **Long Press**.

a.

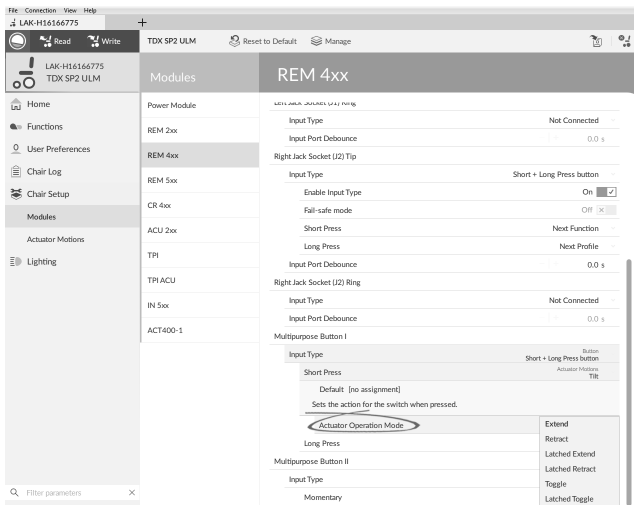

If actuator motion is assigned to parameter, **Actuator Operation Mode** must be selected. The options are:

- **Extend**
- **Retract**
- **Latched Extend**
- **Latched Retract**
- **Toggle**
- **Latched Toggle**

4. If **Momentary button** is selected, assign desired action to button.
  - a. If actuator motion is assigned to parameter, **Actuator Operation Mode** must be selected.

### 10.13 Installing / Setting up alternative inputs

There are different types of alternative inputs, that interface differently to the system. Connect the components to the particular inputs, see table below.

Component	Input
Sip and Puff	Input Module IN5xx
Sip and Puff Head Array	Input Module IN5xx
Pediatric Compact Joystick	Input Module IN5xx
Head Array	TPI
Chin control	TPI
Compact Single Switch Joystick	TPI
Four Switch Proximity Array	TPI
Remote Stop Switch	Power Module

 To install a Remote Stop Switch, just connect to the Power Module using the interface cable and to the 4-way connector using the Bus cable, see wiring diagram 3.8 *Wiring Diagrams*, page 17. Programming is not necessary.

#### Programming

1. Open **Functions**.
2. Add new profile or add user function to existing profile. For more information about adding profiles and functions, refer to 10.1 *Profile and Function Actions*, page 93.

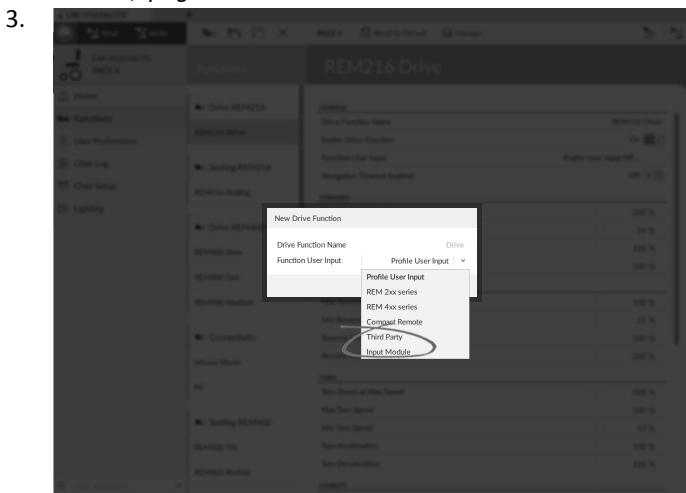

Set **Function User Input** to **Input Module** or to **Third Party**, depending on component input.

 Same procedure for drive, seating and connectivity functions.

4. Open **Chair Setup** → **Modules** → **IN 5xx** or **TPI**, depending on component input.

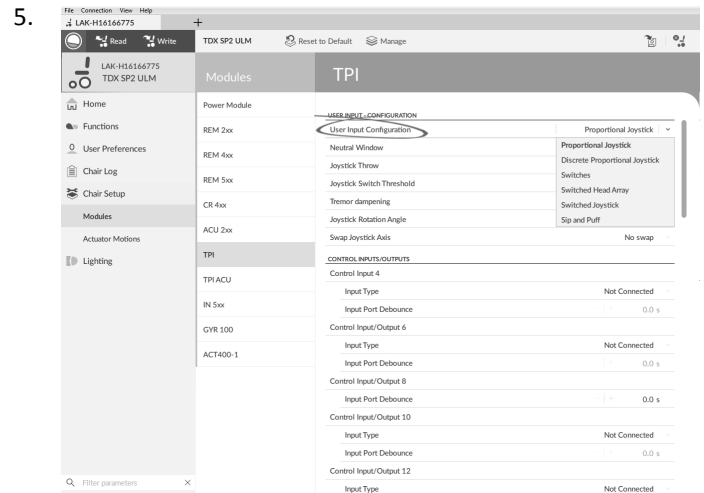

Set **User Input Configuration** to desired component. Options are:

- Proportional Joystick: Pediatric Compact Joystick, Chin Control, Compact Single Switch Joystick
- Discrete Proportional Joystick: not used
- Switches: Four Switch Proximity Array , Sip and Puff Head Array
- Switched Head Array: Head Array
- Switched Joystick: not used
- Sip and Puff: Sip and Puff

6. Depending on component, modify other parameters. For switched inputs, such as Sip and Puff, parameters are found under **User Preferences**, refer to 5.2.1 *Overview User Preferences*, page 52.

 For more information about installing a Sip and Puff, refer to 10.15 *Sip and Puff installation*, page 107.

### 10.14 Installing / Setting up Alternative Outputs

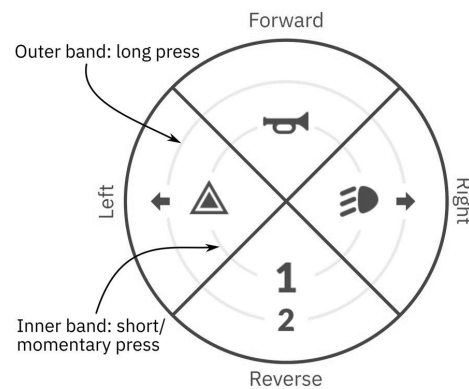

Fig. 10-25 Activation quadrants and bands

The utility function card allows the user to control lighting functions or external outputs using the output module DLX-OUT500. Switches are represented on a utility function card with icons located on two circular activation bands, short/momentary press and long press, within four quadrants (see 10-25 *Activation quadrants and bands*, page 106). The activation time to distinguish between short press and long press can be changed in user preferences, see 5.2.1 *Overview User Preferences*, page 52.

The quadrant and the position of the icons on the bands show the user how to select and operate the switches with their user input.

The following instruction shows you how to program the first control output of DLX-OUT500 using a short/momentary press forwards as an example.

1. Open Functions.
2. Add new utility function or open existing utility function. See 10.1 Profile and Function Actions, page 93.
3. Scroll to section about your desired input command, like Forward Momentary/Short Press.
- 4.

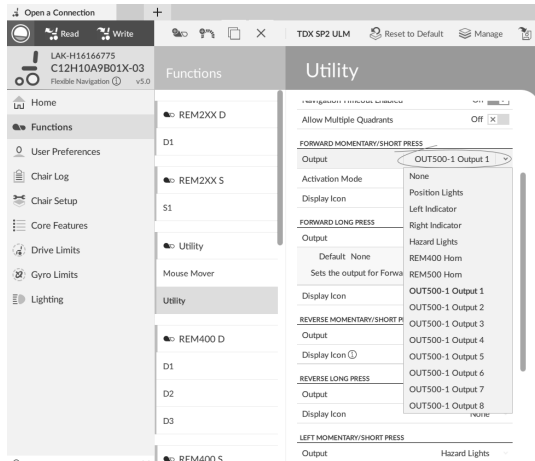

Fig. 10-26

Assign output OUT500–1 Output 1 to parameter Output.

- 5.

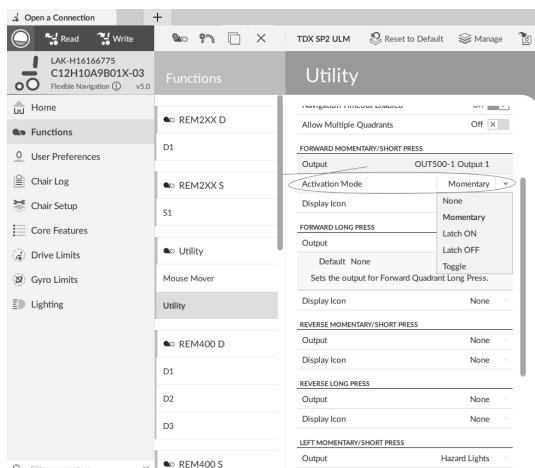

Fig. 10-27

Set parameter Activation Mode to desired value. Following modes are available from list:

None	—
Momentary	Activate an output as long as switch is selected. When choosing this mode it is not possible to configure second band for this direction.
Latch ON	Activate an output and remain activated when switch is deselected.
Latch OFF	Deactivate an output and remain deactivated when switch is deselected.
Toggle	Change current output state and remain this new state when switch is deselected.

- 6.

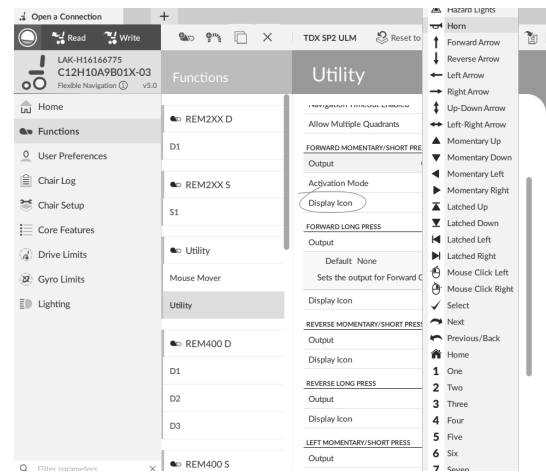

Fig. 10-28

Set parameter Display Icon to desired value. Select a display icon from list of available icons.

7. Modify parameters for the other commands.
8. Scroll to section General.
- 9.

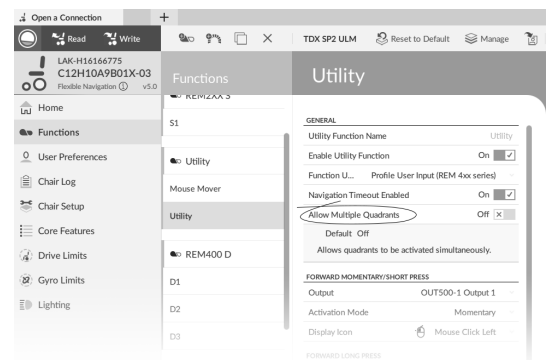

Fig. 10-29

Set parameter Allow Multiple Quadrants to On to allow switching two outputs simultaneously.

## 10.15 Sip and Puff installation

A Sip and Puff module is included in the input module.

A Sip and Puff module provides the user with the ability to activate four digital inputs with their breath via a tube depending on pressure level, hard or soft, and direction, sip or puff. These inputs can be used to control driving or seating actions.

1. Open **Functions**.
2. Add user function for Sip and Puff module. For more information about adding profiles and functions, refer to 10.1 Profile and Function Actions, page 93.

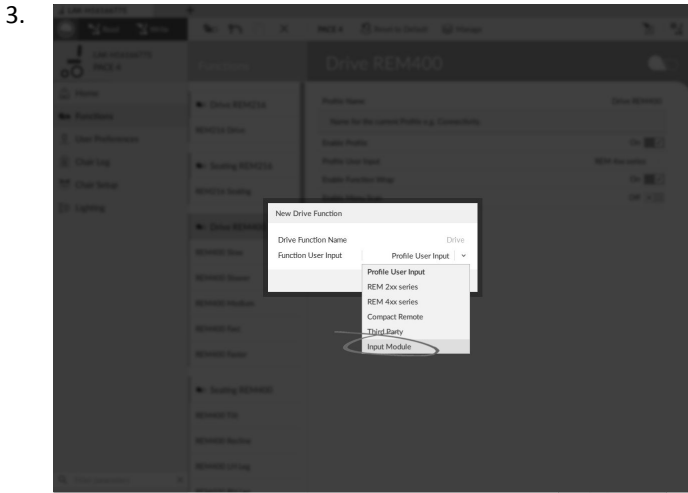

Set Function User Input to Input Module.

Same procedure for drive, seating and connectivity functions.

4. Open Chair Setup → Modules → IN 5xx.

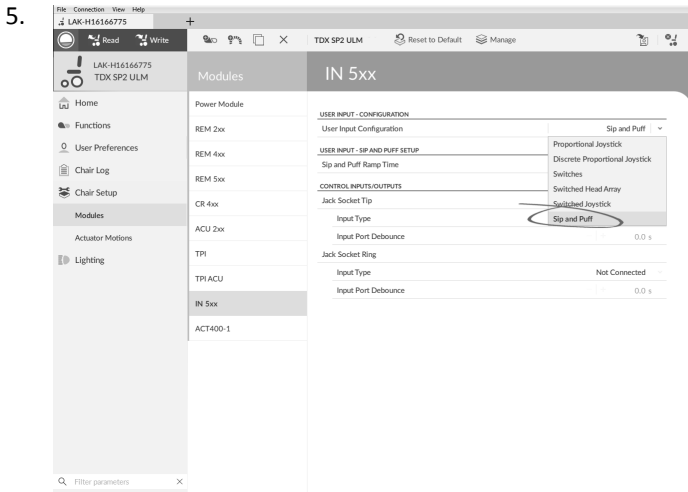

Set User Input Configuration to Sip and Puff.

6. Calibrate Sip and Puff module, refer to 10.15.1 Sip and Puff calibration, page 108

7. Open User Preferences to adjust veer behavior for switched inputs. For more information refer to 5.2.1 Overview User Preferences, page 52.

### 10.15.1 Sip and Puff calibration

Primary input operations, such as driving, are disabled when using the calibration tool. This is for safety reasons to prevent unintended operation when calibrating.

There are three pressure zones for each pressure direction (sip and puff):

- Neutral zone,
- soft zone and
- hard zone.

The Sip and Puff module’s response to a sip or puff input, depends on which zone the pressure falls within: hard or soft. Pressures within the neutral zone are ignored.

Since all users have different capabilities, the Sip and Puff module can be calibrated to change the size and position of these zones. The zones need to be set so that a user can control the wheelchair comfortably and consistently. A Sip

and Puff calibration tool is used to determine the pressure thresholds that define the zones. These thresholds are:

- Minimum limit for soft puff,
- minimum limit for hard puff,
- minimum limit for soft sip and
- minimum limit for hard sip.

To calibrate the Sip and Puff module, you have to record pressure measurements from a series of pressure samples performed by the user and adjust the four pressure thresholds accordingly.

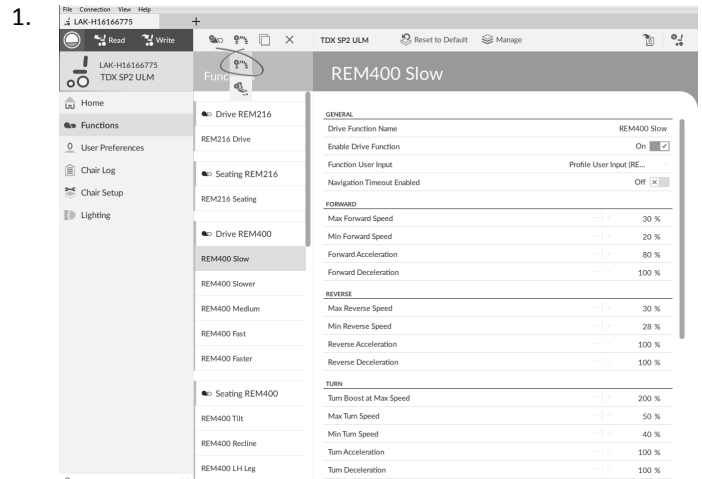

1. Open Connection in menu bar.

2. Select Sip and Puff Calibration.



(A)	Hard zone for puff input
(B)	Threshold slider to adjust minimum limit for hard puff
(C)	Soft zone for puff input
(D)	Threshold slider to adjust minimum limit for soft puff
(E)	Neutral zone for puff input
(F)	Neutral zone for sip input
(G)	Threshold slider to adjust minimum limit for soft sip
(H)	Soft zone for sip input
(I)	Threshold slider to adjust minimum limit for hard sip
(J)	Hard zone for sip input

4. User performs hard puff, soft puff, hard sip and soft sip in no specific order. For each sip and puff, a pressure level  $\text{K}$  is recorded on calibration tool. Based on these recorded levels, you determine best level at which to set each pressure threshold.
5. Drag corresponding Threshold sliders.
  - For soft puff, drag threshold slider  $\text{D}$  to position just below user's soft puff. Any subsequent pressure below threshold slider  $\text{D}$  is in neutral zone  $\text{E}$  and is ignored. Pressure above threshold slider  $\text{D}$  and below threshold slider  $\text{B}$  is in soft zone  $\text{C}$  and determined a soft puff.
  - For hard puff, drag threshold slider  $\text{B}$  to position just below user's hard puff. Pressure below threshold slider  $\text{B}$  is not considered as hard puff. Pressure above threshold slider  $\text{B}$  is in hard zone  $\text{A}$  and determined as hard puff.
  - For soft sip, drag threshold slider  $\text{G}$  to position just above user's soft sip. Any subsequent pressure above threshold slider  $\text{G}$  is in neutral zone  $\text{F}$  and is ignored. Pressure below threshold slider  $\text{G}$  and threshold slider  $\text{I}$  is in soft zone  $\text{H}$  and determined as soft sip.
  - For hard sip, drag threshold slider  $\text{I}$  to position just above user's hard sip. Pressure above threshold slider  $\text{I}$  is not considered as hard sip. Pressure below threshold slider  $\text{I}$  is in hard zone  $\text{J}$  and determined as hard sip.

**Sip and Puff Ramp Time**

The **Sip and Puff Ramp Time** defines the amount of time that a pressure input must remain in the soft zone before it is registered as a soft sip or puff. Consequently, it also provides:

- Time for a user to cross from the neutral zone to the hard zone and
- a filter for any noise (unintentionally pressures) at the zone boundaries.

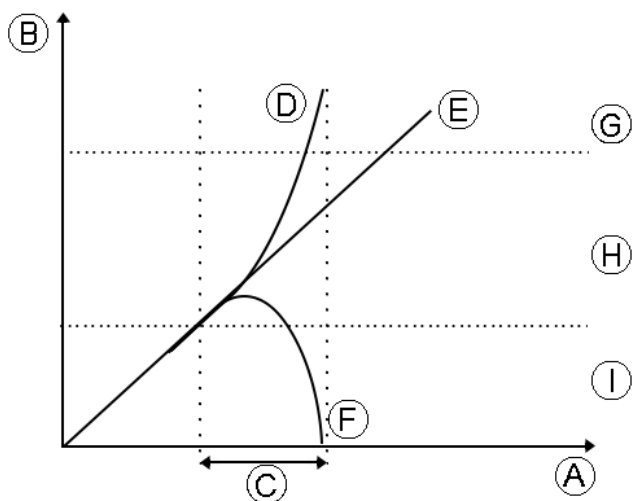

The ramp time  $\text{C}$  begins at the point where the pressure input  $\text{D}$ ,  $\text{E}$  or  $\text{F}$  crosses into soft zone  $\text{H}$  — either from neutral zone  $\text{I}$ , when pressure is increasing, or from hard zone  $\text{G}$ , when pressure decreases. A pressure input  $\text{D}$  that reaches the hard zone before ramp time expires, is registered as a hard sip or puff. A pressure input  $\text{E}$  within soft zone at the end of ramp time is registered as a soft sip or puff. Pressure inputs  $\text{F}$  that fall away into neutral zone before ramp time expires are not registered as an input.

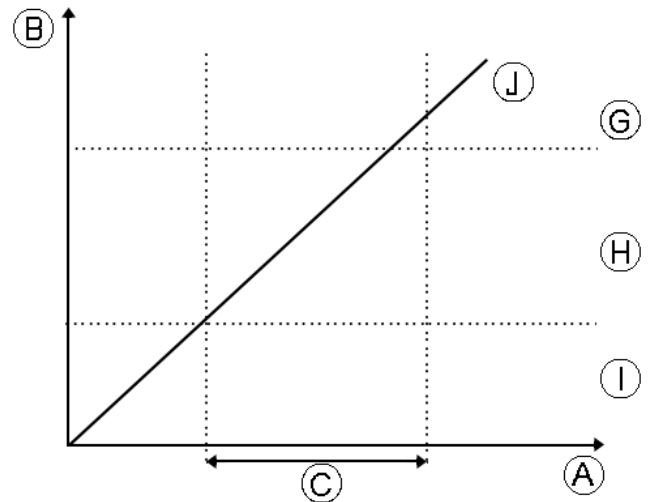

When setting **Sip and Puff Ramp Time**, consideration should be given to users, who cannot produce a hard sip or puff within the ramp time. If ramp time is set too low, a user may not be able to reach the hard zone  $\text{G}$  in time and a soft sip or puff is registered instead of the intended hard sip or puff. For users who need more time to reach hard zone, the ramp time  $\text{C}$  needs to be extended, so the pressure input  $\text{I}$  is registered as a hard sip or puff.

1. Open **Chair Setup** -> **Modules** -> **IN 5xx**.
2. Adjust **Sip and Puff Ramp Time**.

# 11 Diagnostics

Diagnostic options:

- System Summary
- Active Errors
- Event Log
- Chair Statistics
- Real-time diagnostics

## 11.1 Viewing System Summary

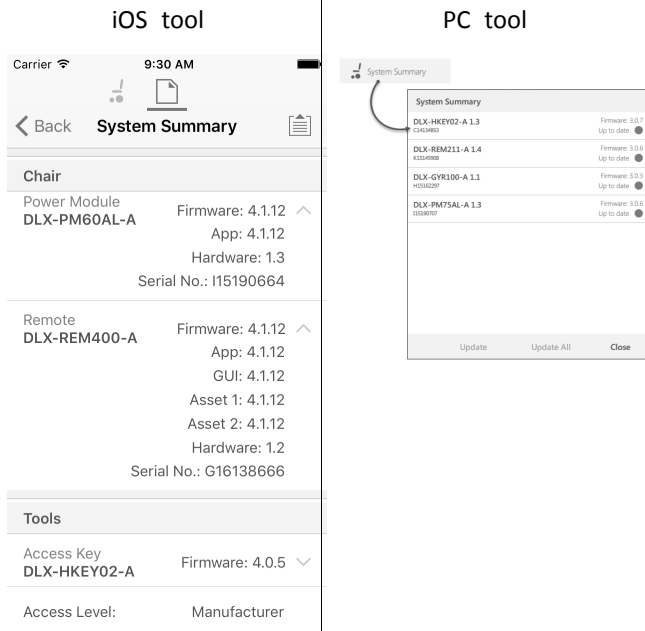

Click on the **System Summary** button to view the **System Summary** screen.

The **System Summary** screen displays details of the system's connected modules, such as:

- Connected modules
- Module software version
- Module serial number
- Access Level of LiNX Access Key

Click on **Back** or **Close** button, to exit the **System Summary**.

## 11.2 Viewing Active Errors

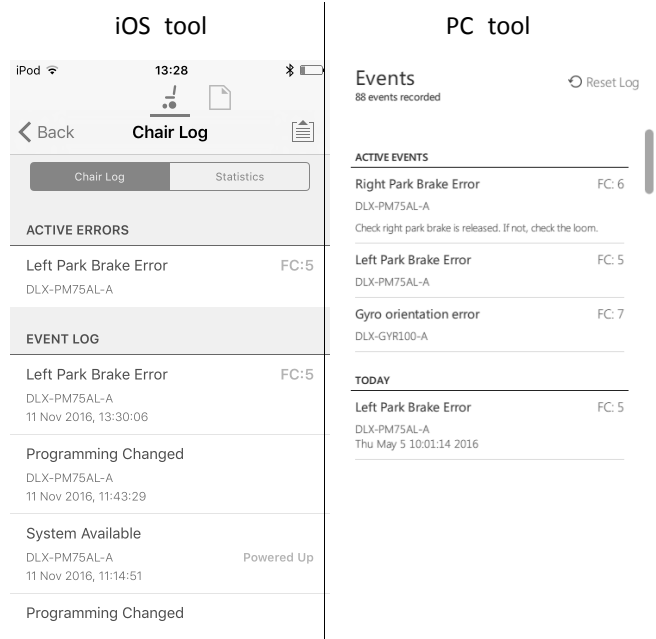

Click on the **Active Errors** button to view which errors, if any, are current. Each entry in this log displays the error, its flash code (e.g. FC5) and the component where the error is. Click on the error entry to reveal an error description with more helpful information about the error.

Click on **Back** or **Close** button to exit **Active Errors**.

## 11.3 Viewing Chair Statistics

Go to **Chair Log** to view a comprehensive list of current system statistics. The chair statistics are divided into the following sections:

- Battery usage
- Drive statistics

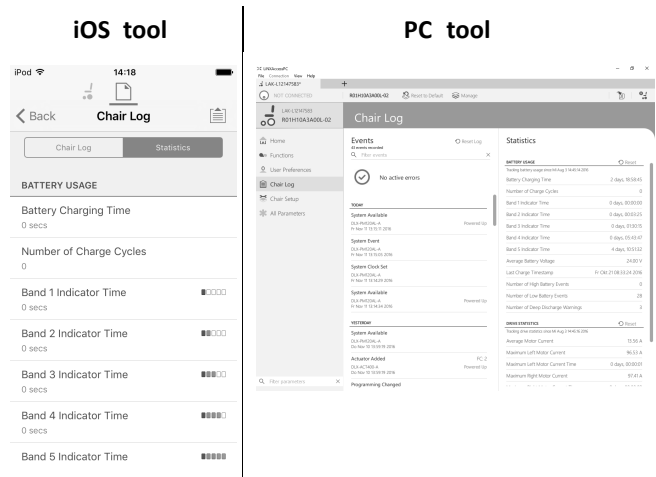

### Reading battery usage

To view more information about a battery statistic, click on a statistic and a helpful description is displayed in the local help panel.

The available statistics are detailed in the following table.

Battery usage statistics	Details
Battery Charging Time	The time that the batteries have been charged for.
Number of Charge Cycles	The number of times the batteries have been charged.
Band 1 Indicator Time	The total time the LiNX system is operated with the state of charge between 0 and 20%.
Band 2 Indicator Time	The total time the LiNX system is operated with a state of charge between 20 and 40%.
Band 3 Indicator Time	The total time the LiNX system is operated with a state of charge between 40 and 60%.
Band 4 Indicator Time	The total time the LiNX system is operated with a state of charge between 60 and 80%.
Band 5 Indicator Time	The total time the LiNX system is operated with a state of charge between 80 and 100%.
Average Battery Voltage	The average battery voltage over the last 31 days.
Last Charge Timestamp	The date and time when the batteries were last put on charge.
Number of High Battery Events	The number of high battery warnings.
Number of Low Battery Events	The number of low battery warnings.
Number of Deep Discharge Warnings	The number of deep discharge warnings.
Battery Usage Last Reset	Date when these statistics were last reset.

### Resetting battery usage

1.

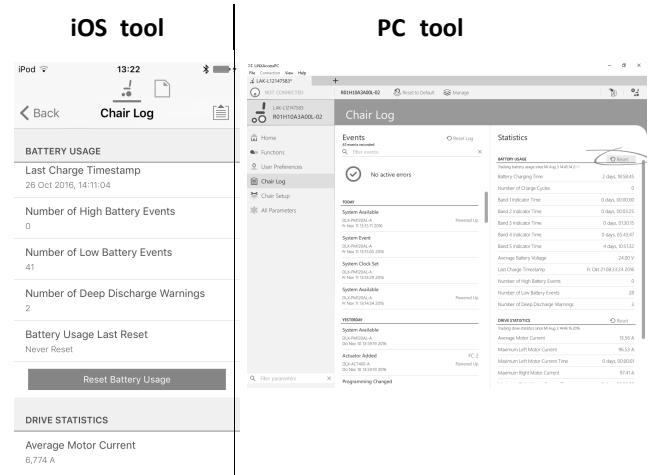

Click on **Reset Battery Usage** button.

2.

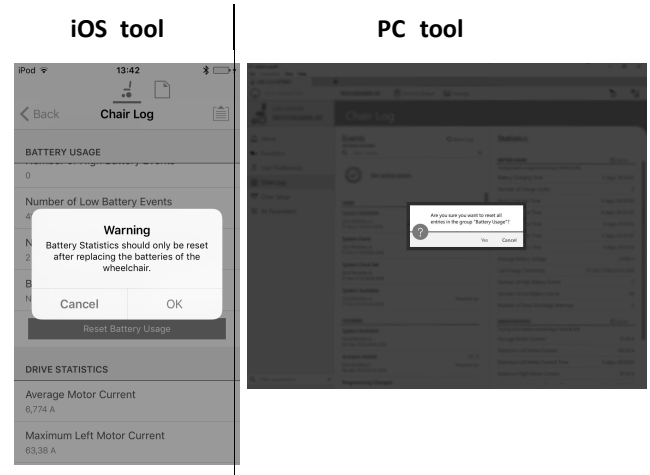

Click on **OK** or **Yes** to continue.

### Reading drive statistics

To view more information about a drive statistic, click on the statistic and a description is displayed in the local help panel.

The available statistics are detailed in the following table.

Drive statistic	Details
Average Motor Current	The average current drawn across all motors while driving.
Maximum Left Motor Current	The peak measured motor current.
Maximum Left Motor Current Time	Time spent drawing the "Maximum Drive Current Draw".
Maximum Right Motor Current	The peak measured motor current.
Maximum Right Motor Current Time	Time spent drawing the Maximum Drive Current Draw".
Powered Up Time	The total time that the wheelchair controller is powered up.
Drive Time	The total time that the wheelchair has been driven.

Drive statistic	Details
Average Drive Time	Average drive time.
Time Near Maximum Current	The duration the current was within 20% of maximum threshold.
Drive Statistics Last Reset	Date when these statistics were last reset.

**Resetting drive statistics**

1.

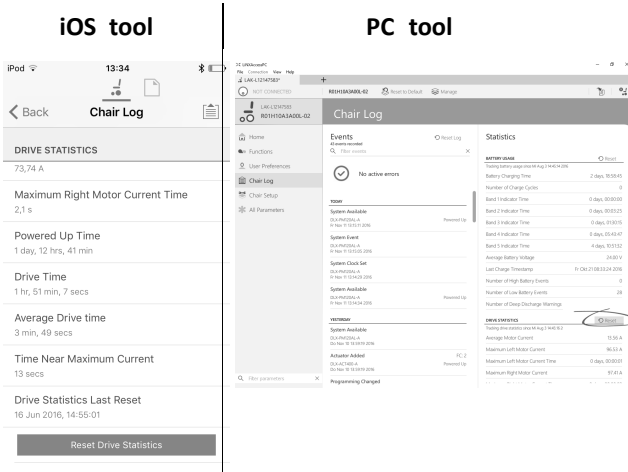

Click on **Reset Drive Statistics** button.

2.

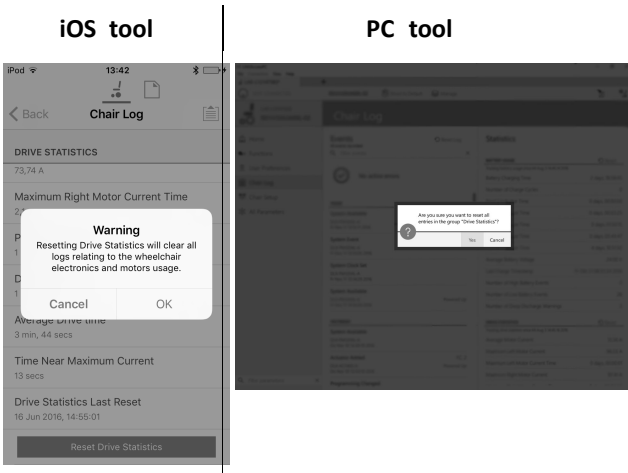

Click on **OK** or **Yes** to continue.

Click on **Back** or **Close** button to exit the **Chair Statistics**

**11.4 Viewing Live Diagnostics**

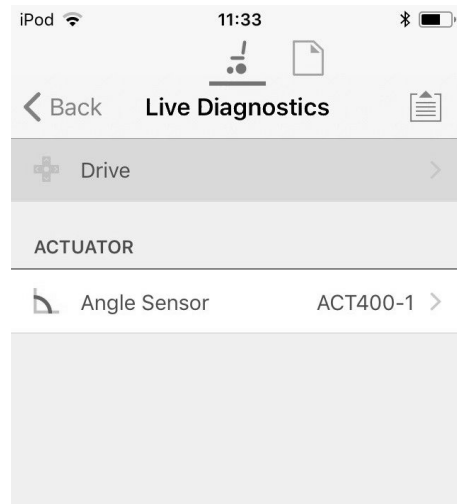

Fig. 11-1

The Live Diagnostics are only available when the LINX Access iOS tool is connected to a wheelchair. The parameters (see *Parameter list, page 112*) on the Live Diagnostics screen are split into two categories:

- Drive, and
- Actuators.

**Parameter list**

**Drive**

Speed Demand (%)

Turn Demand (%)

**Left Motor**

- Voltage (V)
- Current (A)
- Resistance (mΩ)

**Right Motor**

- Voltage (V)
- Current (A)
- Resistance (mΩ)

Battery Voltage (V)

Speed Dial (%)

**Actuators**

Sensor Angle (°)

1. Click Live Diagnostics button.
2. Click desired category to view real-time graphs and data.
3. Click Back button twice to exit Live Diagnostics.

**11.5 Clearing the event log**

This feature is only available when a wheelchair is in **Connection context** mode.

**PC tool**



To clear the event log, click on the **Reset Log** button at the top of the logs.



## 12 Structure of Program Names

By default, the file name, program name and system name are composed of the wheelchair configuration. The program name can be changed to a more familiar name.

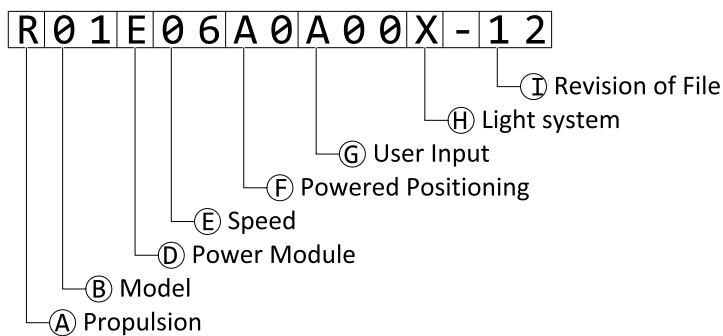

Fig. 12-1 Example of a Kite program name (2 pole motor, drive only) using naming format up to July 2018

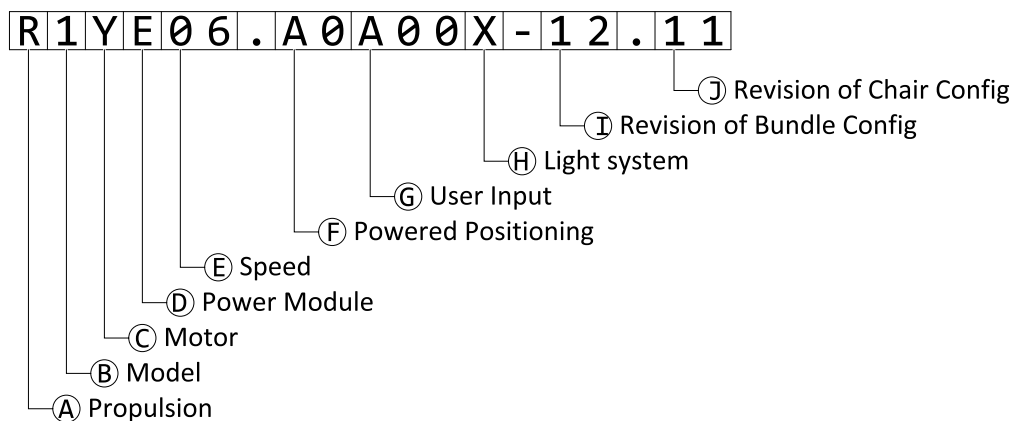







Fig. 12-2 Example of a Kite program name (2 pole motor, drive only) using naming format as of August 2018

(A)	Propulsion
(B)	Model
(C)	Motor
(D)	Power Module
(E)	Speed
(F)	Powered Positioning
(G)	User Input
(H)	Light System
(I)	Revision of Bundle Configuration or File
(J)	Revision of Chair Configuration

### 12.1 Where-Used Matrices

Model	Motor								
									
	Inline (Z)	LS (Y)	HS (X)	LS (W)	HS (V)	HD (U)	LS (T)	HS (S)	UHS (R)
Kite	-	X	X	X	X	-	-	-	X
TDX SP2	-	-	-	X	X	-	X	X	X
Bora/Spectra XTR	-	X	X	X	X	-	-	-	-
Fox	X	-	-	-	-	-	-	-	-
Storm <sup>4</sup> , Storm <sup>4</sup> X-plore	-	-	-	X	X	-	-	-	X
Storm <sup>4</sup> Max	-	-	-	-	-	X	-	-	-

Motor		Type of LiNX power module	Speed				
			03	06	08	10	12
Z	Inline motor	DLX-PM60	X	X	X	-	-
Y	2 pole (low speed)	DLX-PM75 / DLX-PM75AL	X	X	-	-	-
X	2 pole (high speed)		-	-	X	X	-
W	4 pole legacy (low speed)	DLX-PM120 / DLX-PM120AL	X	X	-	-	-
V	4 pole legacy (high speed)		-	-	X	X	-
U	4 pole legacy (HD)		-	X	-	-	-
T	DuraWatt (low speed)		-	X	-	-	-
S	DuraWatt (high speed)		-	-	X	X	-
R	DuraWatt (Ultra high speed)		-	-	-	X <sup>3</sup>	X

Model	Powered Positioning			
	Standard / Modulite seat	Max seat	Recaro seat	Ultra Low Maxx seat
Kite	X	X	-	-
TDX SP2	X	X	-	X
Bora/Spectra XTR	X	X	-	-
Fox	X	-	-	-
Storm <sup>4</sup> , Storm <sup>4</sup> X-plore	X	-	X	-
Storm <sup>4</sup> Max	X	X	-	-

## 12.2 Naming Format

3. France only

	Up to July 2018	As of August 2018
Ⓐ	R = Rear wheel drive C = Centre wheel drive F = Front wheel drive	
Ⓑ	01 = Kite 02 = TDX SP2 - legacy motors 12 = TDX SP2 - DuraWatt motors 03 = Bora/Spectra XTR 04 = Fox 05 = Storm <sup>4</sup> , Storm <sup>4</sup> X-plore 06 = Storm <sup>4</sup> Max	1 = Kite 2 = TDX SP2 3 = Bora/Spectra XTR 4 = Fox 5 = Storm <sup>4</sup> , Storm <sup>4</sup> X-plore, Storm <sup>4</sup> Max
Ⓒ	Not used. Included in Ⓑ.	Z = Inline motor Y = 2 pole (low speed) X = 2 pole (high speed) W = 4 pole legacy (low speed) V = 4 pole legacy (high speed) U = 4 pole legacy (HD) T = DuraWatt (low speed) S = DuraWatt (high speed) R = DuraWatt (ultra high speed)
Ⓓ	A = not used B = not used C = DLX-PM60 D = not used E = DLX-PM75 F = DLX-PM75AL G = DLX-PM120 H = DLX-PM120AL	
Ⓔ	03 06 08 10 12	
Ⓕ	A1 = Powered “fixed pivot” tilt (20°) A2 = Powered tilt (30°), CoG shift A3 = Seat lifter & powered tilt (300 mm, 30°), CoG shift A4 = Powered tilt (12°) A5 = Seat lifter & powered tilt (300 mm, 28°), CoG shift A6 = Column lifter & “fixed pivot” tilt (250 mm, 25°)	<b>Drive only</b> A0 = w/o actuators <sup>4</sup> <b>Standard seat / Modulite seat</b> A1 = Powered “fixed pivot” tilt (20°) A2 = Powered tilt (30°), CoG shift A3 = Lifter & tilt (300 mm, 30°), CoG shift A4 = Column lifter & “fixed pivot” tilt (250 mm, 25°)

4. If light system is equipped: use profile A1, B1 or C1 (according to seat)

	<b>Up to July 2018</b>	<b>As of August 2018</b>
Ⓕ	<p>A7 = Recaro with “fixed pivot” tilt (25°)</p> <p>A8 = Recaro with column lifter &amp; “fixed pivot” tilt (250 mm, 25°)</p> <p>A9 = Ultra Low Maxx with tilt (50°), CoG shift</p> <p>B0 = Ultra Low Maxx with lifter &amp; tilt (300 mm, 45°), CoG shift</p>	<p><b>Max seat</b></p> <p>B1 = Powered “fixed pivot” tilt 25°</p> <p>B2 = Lifter &amp; tilt (300 mm, 28°), CoG shift</p> <p><b>Recaro seat</b></p> <p>C1 = Powered “fixed pivot” tilt (25°)</p> <p>C2 = Column lifter &amp; “fixed pivot” tilt (250 mm, 25°)</p> <p><b>Ultra Low Maxx seat</b></p> <p>D1 = Powered tilt (50°), CoG shift + LNX</p> <p>D2 = Lifter &amp; tilt (300 mm, 45°), CoG shift + LNX</p> <p>D3 = Powered tilt (50°), CoG shift + ADP</p> <p>D4 = Lifter &amp; tilt (300 mm, 45°), CoG shift + ADP</p> <p>D5 = Powered tilt (50°), CoG shift + Pivot Plus</p> <p>D6 = Lifter &amp; tilt (300 mm, 45°), CoG shift + Pivot Plus</p>
Ⓖ	<p>A00 = DLX-REM1XX/DLX-REM2XX + DLX-REM050</p> <p>A01 = DLX-REM2XX + LNX</p> <p>A02 = DLX-REM2XX + ADP</p> <p>A03 = DLX-REM2XX + Pivot Plus</p> <p>A04 = DLX-REM2XX/400 + ACU200</p> <p>B01 = DLX-REM400 + 4Q-P + LNX</p> <p>B02 = DLX-REM400 + 4Q-P + ADP</p> <p>B03 = DLX-REM400 + 4Q-P + Pivot Plus</p> <p>C01 = DLX-REM400 + 3Q-D + LNX</p> <p>C02 = DLX-REM400 + 3Q-D + ADP</p> <p>C03 = DLX-REM400 + 3Q-D + Pivot Plus</p> <p>C04 = DLX-REM400 + 4Q-D + LNX</p> <p>C05 = DLX-REM400 + 4Q-D + ADP</p> <p>C06 = DLX-REM400 + 4Q-D + Pivot Plus</p>	<p>A00 = DLX-REM1XX/DLX-REM2XX + DLX-REM050<sup>5</sup></p> <p>A04 = DLX-REM2XX/400 + ACU200</p> <p>B02 = DLX-REM400 + 4Q-P</p> <p>C01 = DLX-REM400 + 3Q-D</p> <p>C04 = DLX-REM400 + 4Q-D</p>
Ⓗ	<p>T = Traditional</p> <p>L = LED</p> <p>X = w/o light<sup>6,7</sup></p>	
①	Revision of file	Revision of bundle configuration
①	Not used. Included in ①.	Revision of chair configuration

5. Use only if DLX-REM1XX or DLX-REM050 are equipped to the wheelchair. Otherwise use profile A04.

6. If only programs with activated light system are available: use profile LED instead.

7. By default, Ultra Low Maxx programs are with deactivated light system. See 8.5 *Modifying Lighting Parameters*, page 73 and 10.3.1 *Modifying Lighting Parameters*, page 94 to activate light system.



## Invacare Sales Companies

### Australia:

Invacare Australia Pty. Ltd.  
1 Lenton Place, North Rocks NSW  
2151  
Australia  
Phone: 1800 460 460  
Fax: 1800 814 367  
orders@invacare.com.au  
www.invacare.com.au

### United Kingdom:

Invacare Limited  
Pencoed Technology Park, Pencoed  
Bridgend CF35 5AQ  
Tel: (44) (0) 1656 776 222  
Fax: (44) (0) 1656 776 220  
uk@invacare.com  
www.invacare.co.uk

### Canada:

Invacare Canada L.P.  
570 Matheson Blvd East, Unit 8  
CDN Mississauga, On. L4Z 4G4  
Phone: (905) 890 8300  
Toll Free: 800.668.5324  
www.invacare.ca

### Eastern Europe, Middle East & CIS:

Invacare EU Export  
Kleiststraße 49  
D-32457 Porta Westfalica / Germany  
Tel: (49) (0)57 31 754 540  
Fax: (49) (0)57 31 754 541  
webinfo-eu-export@invacare.com  
www.invacare-eu-export.com

### Ireland:

Invacare Ireland Ltd,  
Unit 5 Seatown Business Campus  
Seatown Road, Swords, County Dublin  
Tel : (353) 1 810 7084  
Fax: (353) 1 810 7085  
ireland@invacare.com  
www.invacare.ie

### New Zealand:

Invacare New Zealand Ltd  
4 Westfield Place, Mt Wellington 1060  
New Zealand  
Phone: 0800 468 222  
Fax: 0800 807 788  
sales@invacare.co.nz  
www.invacare.co.nz



### Manufacturer:

Invacare Deutschland GmbH  
Kleiststraße 49  
D-32457 Porta Westfalica  
Germany

